

# QFA1000, QFA1001

## Room Hygrostats



QFA1001



QFA1000

### Description

The room hygrostats are used for controlling and monitoring relative humidity in ventilation or air conditioning facilities. They ensure room humidity control within the selectable range of 30 to 90% relative humidity by controlling humidification or dehumidification equipment. They can also be used for monitoring minimum or maximum humidity levels.

### Features

- Hygrostat with single-pole microswitch
- Humidity measuring element made of stabilized plastic
- Setpoint knob for the upper switching point
- Mounts directly on the wall or on a recessed conduit box

### Application

- For controlling humidification equipment
- For controlling dehumidification equipment

### Product Numbers

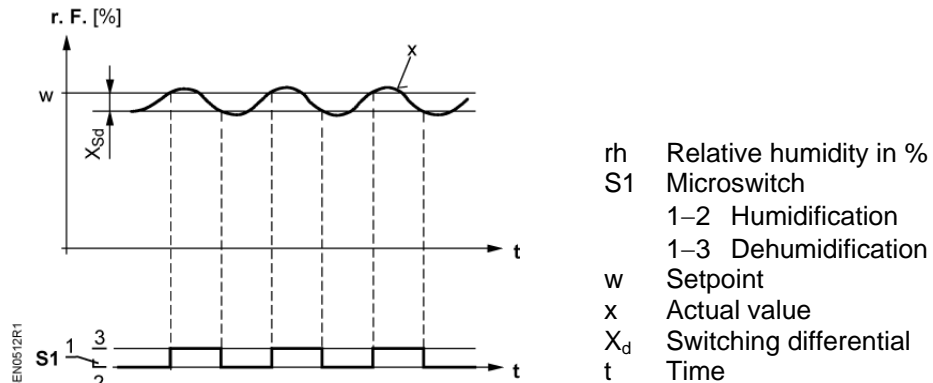
Product Number	Setpoint Setting Range	Switching Differential <sup>1</sup>		Setpoint Adjustment
		Statically	Dynamically	
QFA1000	30 to 90% rh	Approx. 4% rh	6% rh	Internally
QFA1001				Externally

<sup>1)</sup> The static switching differential is determined at a constant ambient humidity by turning the setting knob.

The dynamic switching differential is determined by changing the ambient humidity while maintaining the same setpoint adjustment; only the dynamic switching differential is of practical value.

## Mode of Operation

The hygrostat acquires the relative humidity of the ambient air with its humidity measuring element, which is a stabilized, plastic strip. The strip actuates a microswitch with a fixed switching differential  $X_d$  and a potential-free contact output (SPDT), depending on the relative humidity of the air. If the actual humidity deviates from the adjusted setpoint, the hygrostat switches the associated humidification or dehumidification equipment on or off as shown in the following function diagram (Figure 1).



**Figure 1. Function Diagram.**

Due to the measuring element's aging effect, the switching point drifts slowly and constantly. For this reason, recalibration may be required in due time.

At temperatures other than the calibration temperature, the switching point drifts systematically (temperature influence). Also, in the case of fast humidity changes, the switching point will temporarily be shifted.

## Mechanical Design

### QFA1001

The room hygrostat is designed for wall mounting, and fits on most commercially available recessed conduit boxes. The cables are introduced either from the rear (recessed conduit boxes) or from above (surface-run wires), after removing the knock-outs.

The unit consists of base and cover that can be separated (snap-on connection).

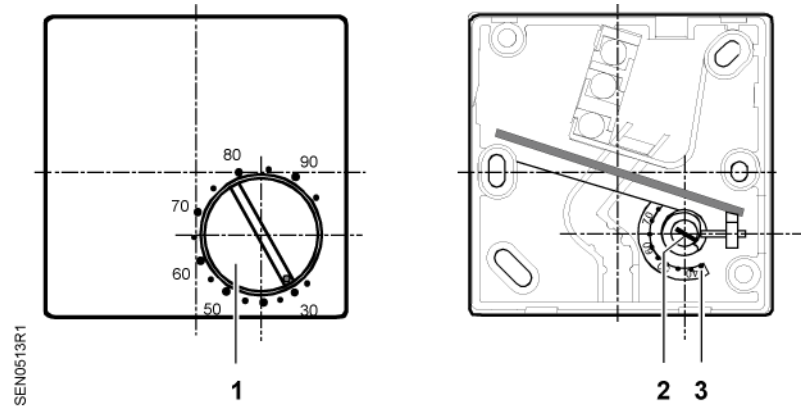
The base accommodates the humidity measuring element, setpoint setting element with setting spindle, scale, microswitch, and screw terminals.

The cover carries the removable setpoint knob with its imprinted scale.

### QFA1000

This model has the same basic design as the QFA1001, but without an external setpoint knob. The setpoint can only be adjusted when the cover is removed.

**Operating Elements**



- 1 Setpoint knob with scale – only with QFA1001
- 2 Setpoint setting spindle
- 3 Scale for setpoint adjustment with QFA1000

**Figure 2. Operating Elements.**

**Mounting Notes**

The base has cable entries at the rear for mounting the room hygrostat on recessed conduit boxes. For wall mounting, appropriate holes at the top or bottom can be knocked out.

**Mounting Choices**

**Mounting Location**

The hygrostat should be mounted on an inner wall approximately 4.9 feet (1.5 m) above the floor and at least 1.6 feet (0.5 m) from the closest wall.

Mount the unit where there is a natural circulation of room air (do not mount near drafts, in corners, behind curtains, too close to doors and windows, or on an outer wall). Sources of heat and refrigeration (radiators, computers, televisions, concealed heating pipes, hot or cold water pipes) must be at an adequate distance.

The hygrostat should not be exposed to direct sunlight.

**Mounting Instructions**

Installation Instructions for the room hygrostat are available online.

**Specifications**

**Functional data**

Setpoint range	30 to 90% rh
Temperature operating range	32°F to 122°F (0°C to 50°C)
Humidity measuring element	Stabilized plastic band
Control mode	Two-position
Time constant (v = 0.2 m/s)	Approximately 5 minutes
Switching differential	See <i>Product Numbers</i>
Setting accuracy	± 5% rh (can be improved by calibrating on site)
Temperature influence	± 0.5% rh/K
Humidity calibration at	55% rh, 73°F (23°C)
Long-term stability	Approximately – 1.5% rh/a
Type of switch	Potential-free microswitch (SPDT)
Contact rating	
Maximum	5 (3) A, 24 Vac/Vdc
Minimum	100 mA, 24 Vac/Vdc

**Protective data**

Degree of housing protection	P 20 to EN 60 529
Safety class	II to EN 60 730

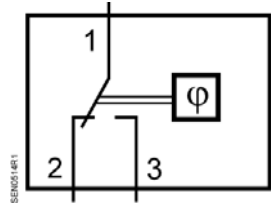
**Electrical connection**

Screw terminals for	Maximum 2 × 16 AWG
---------------------	--------------------

<b>Materials and colors</b>	Base	PPS, Fortron, fiberglass reinforced, Black
	Cover	PC Lexan 940, pure-white
	Humidity measuring element	Plastic
<b>Standards</b>	CE conformity EMC directive	89/336/EEC
	UL	UL873
	cUL	Canadian Standard C22.2 No. 24-93
<b>Weight</b>	QFA1001	3.17 ounces (0.090 kg)
	QFA1000	3.17 ounces (0.090 kg)

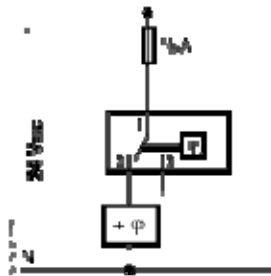
**Wiring Diagrams**

**Internal Diagram**

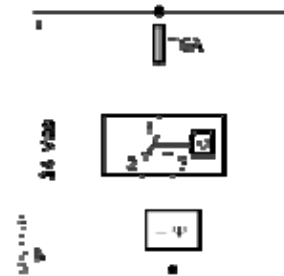


1-2 Humidification  
 1-3 Dehumidification

**Wiring Diagrams**

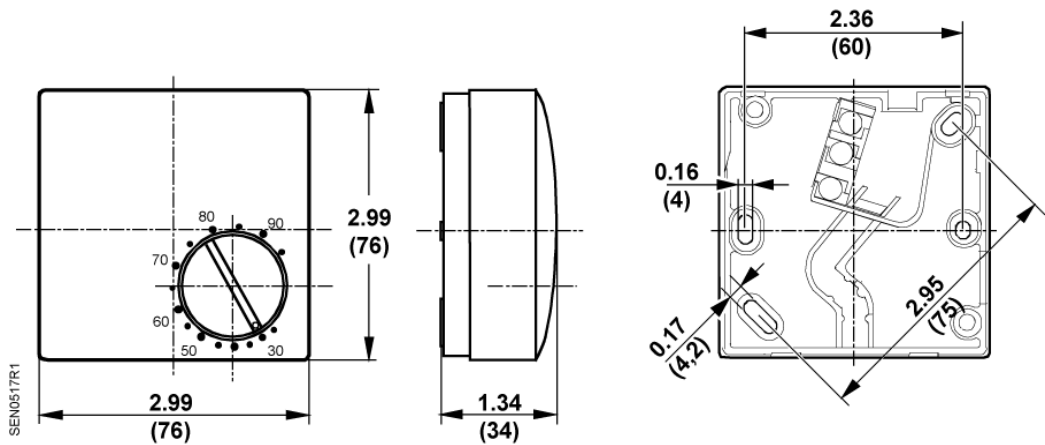


**Figure 3. Humidification.**



**Figure 4. Dehumidification.**

**Dimensions**



**Figure 5. Dimensions in Inches (Millimeters).**

Information in this publication is based on current specifications. The company reserves the right to make changes in specifications and models as design improvements are introduced. Product or company names mentioned herein may be the trademarks of their respective owners.  
 © 2010 Siemens Industry, Inc.