

Rebuild Kit for Vx-7xxx, Vx-8xxx, and Vx-9xxx Globe Valves

Applications

Schneider Electric RYB-7xx, RYB-8xx, and RYB-9xx Globe Valve Rebuild Kits are designed to restore the following valves to their original performance, provided they have undamaged seats: Schneider Electric VB-7000 1/2" to 2" Two-Way and Three-Way Bronze Valves, VB-8000 2-1/2" to 6" Two-Way and Three-Way Flanged Iron Valves, and VB-9000 2-1/2" to 6" Two-Way and Three-Way Flanged Iron Valves. These Rebuild Kits include the necessary stem and plug assemblies, packing, and related parts.

Selection Tables

Each of the selection tables that follow addresses a particular valve type and size. Find the valve's part number and then the corresponding rebuild kit.

Identifying Vx-7xxx Valves

Original-design and enhanced-design Vx-7xxx valves can be identified by the color of their actuator mounting nut. Original-design valves have a silver-colored actuator mounting nut. Enhanced-design valves have a gold-colored actuator mounting nut.

Changing Vx-7xxx Valve Capacity

Within the same pipe size, body type, and trim type, similar plugs are interchangeable. You can change the capacity of an existing Vx-7xxx valve by choosing a different plug having the required Cv.

Rebuild Kits for Vx-7xxx Valves

You can find a chart listing rebuild kits for the Vx-7xxx series valves on **page 17**.

Rebuild Kits with Two Plug Choices

Some rebuild kits for 1/2" and 3/4" valves include two plug choices, one each for original-design and enhanced-design valves. If your kit includes two plugs, only use an original-design plug in an original-design valve body, or an enhanced-design plug in an enhanced-design valve body.

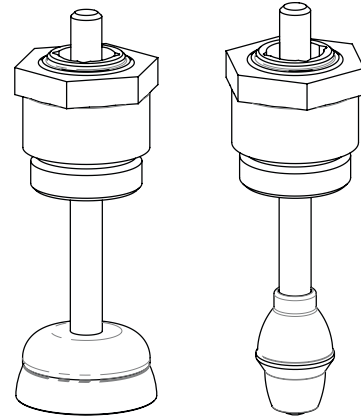

Typical 1/2" to 2" 2-Way

Typical 1/2" to 2" 3-Way

Installation Information

The selection tables are followed by information you use to install the rebuild kits on the various types of valves.

Depressurize the valve to 0 psig before loosening or removing a packing cartridge. Loosening or removing the packing cartridge while the valve is pressurized may cause the valve packing to blow out, thereby inflicting bodily injury or causing hardware damage to the water or steam system.

Applicable Literature

VB-7xxx Installation Instructions	F-27651
VB-8213 General Instructions	F-27193
VB-8223 General Instructions	F-27194
VB-8303 General Instructions	F-27197
VB-9313 General Instructions	F-24393
VB-7200 Data Sheet	F-27649
VB-7300 Data Sheet	F-27650
VB-7263 Data Sheet	F-27687
YBA-622/YBA-635 Installation Instructions	F-17324
YBA-652 Installation Instructions	F-24185
EN205 Water and Steam Systems	F-26080
Schneider Electric Valves Catalog	F-27414

Tools Required for Valve Rebuild

Vx-7xxx Valves Up to 2"	
Tool Number	Description
TOOL-20-1	Packing top wrench
M-370	1-5/8" Narrow open end wrench
n/a	1" Open-end wrench for packing cartridge
n/a	5/16" Open end wrench for stem nuts
n/a	Pipe wrenches for valve installation

Vx-8xxx and Vx-9xxx Valves 2-1/2" to 6"	
Tool Number	Description
n/a	3/4" Open end wrench for stem and cover nuts
n/a	1" Open-end wrench for packing cartridge
n/a	1-1/4" Open end wrench

Vx-7xxx Bronze Globe Valves — 1/2" to 2" (15 mm to 50 mm) Rebuild Procedure

Note: Original-design Vx-7xxx valves have a silver-colored actuator mounting nut. Enhanced-design Vx-7xxx valves have a gold-colored actuator mounting nut.

Disassembly

Disassemble the valve in preparation for rebuild kit installation:

- If the valve is part of a valve assembly (with actuator), remove the actuator and linkage from the valve.
- Depressurize the valve to 0 psig before loosening or removing a packing cartridge. Loosening or removing the packing cartridge while the valve is pressurized may cause the valve packing to blow out, thereby inflicting bodily injury or causing hardware damage to the water or steam system.
- Loosen the packing top nut, using TOOL-20-1.
- Remove the packing cartridge, along with the actuator lock nut. Save the actuator lock nut for reuse.
- On normally open 2-way valves, sizes 1" (25 mm) through 2" (50 mm), remove the bonnet.
- On normally closed 2-way valves, remove the lower threaded cap.
- On 3-way valves, remove the bottom inlet port seat.
- Remove the valve stem and plug assembly from the valve body.
- Check the O-ring or seat for any damage:
- Original-design 2-way and 3-way valves—Inspect the seat in the valve body to ensure there are no nicks or other damage. On 3-way valves, also inspect the seat in the bottom port. Valves with damaged seats cannot be restored for service using a valve rebuild kit.
- Enhanced-design 2-way and 3-way valves—Inspect the O-ring or seat:
 - On 1/2" (15 mm) and 3/4" (20 mm) valves, check that the internal O-ring is present and free from nicks or other damage. If this O-ring is in good condition, rebuild the valve, using the appropriate rebuild kit. If the O-ring is missing or damaged, do not attempt to rebuild the valve. This O-ring is not field-replaceable.
 - On 1" (25 mm) through 2" (50 mm) valves, check the seat in the valve body for nicks or other damage. On 3-way valves, also inspect the seat in the bottom port. Valves with damaged seats cannot be restored for service using a valve rebuild kit.
- On original-design 3-way diverting valves, remove the wiper O-ring from the interior of the valve body.

Reassembly

Reassemble the valve, using the rebuild kit:

- On original-design Vx-7323 and Vx-7325 3-way diverting valves, coat a new wiper O-ring with the silicone grease supplied in the rebuild kit and then install the O-ring into the valve body.
- Install the new stem and plug assembly into the valve body. Be sure to choose the original-design or enhanced-design part, as appropriate for your valve.
Rebuild kits for 1" (25 mm) through 2" (50 mm) valves contain a single replacement plug that can be used for either original-design or enhanced-design valves.
- On normally open 1" (25 mm) through 2" (50 mm) valves, apply Loctite pipe sealent #592 or equivalent on the male threads of the bonnet, and then reinstall and tighten the bonnet to the recommended torque. Refer to the Assembly Torques table in the Assembly Information section applicable to the valve size.
- On 3-way valves and normally closed 2-way valves, apply Loctite pipe sealent #592 or equivalent to the threads of the bottom inlet port seat (3-way valves) or the lower threaded cap (2-way valves), and then reinstall and tighten to the recommended torque. Refer to the Assembly Torques table in the Assembly Information section applicable to the valve size.
- Reinstall the actuator lock nut (saved at disassembly) and a new packing cartridge onto the valve body. Refer to the YBA-622-2 Valve Packing Kits Installation Instructions, F-17324 (included with the packing kit).
- If the valve is part of a valve assembly, reinstall the actuator and linkage according to instructions in the applicable literature.
- Check the valve and actuator for proper operation and then return to service.

Vx-7xxx Bronze Globe Valves – ½” (15 mm) Rebuild Kits

2-Way Normally Open

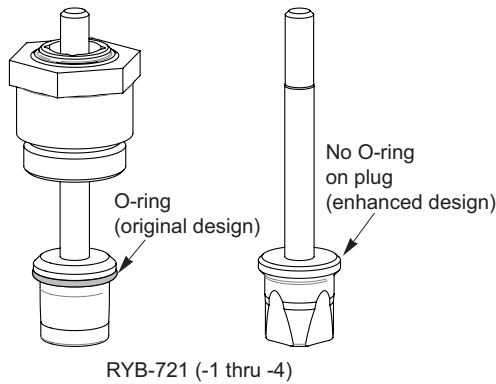

Note: The actual shape of the plug varies with Cv.

2-Way Normally Closed

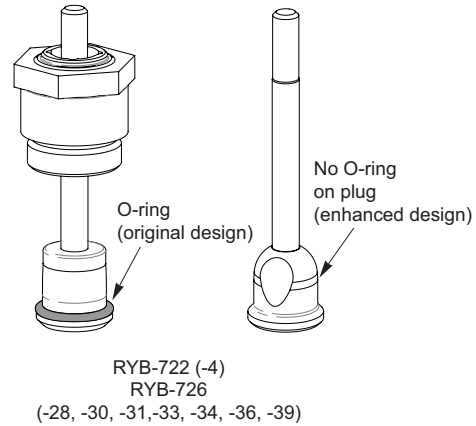

Note: The actual shape of the plug varies with Cv.

Valve Body	Cv	Rebuild Kit	Stem and Plug Assy
Vx-721x-0-x-01	0.4	RYB-721-01	2 b
Vx-721x-0-x-02	1.3	RYB-721-02	2 b
Vx-721x-0-x-03	2.2	RYB-721-03	2 b
Vx-7211-0-3-04	5.0	RYB-721-A4	1 a
Vx-721x-0-4-04	4.4	RYB-721-04	2 b

- a. These kits consist of one stem and plug assembly.
- b. These kits consist of one original-design plug and one enhanced-design plug. Original-design plugs include an O-ring. There is no O-ring on enhanced-design plugs. Enhanced-design valves have an O-ring in the valve seat, which must be intact and functional in order to ensure proper valve performance.
- c. Some kits are used in more than one style of valve body. In that case, the Cv capacity is determined by the combination of the plug and the valve body style.

Valve Body	Cv	Rebuild Kit	Stem and Plug Assy
Vx-722x-0-4-02	1.3	RYB-722-02	2 b
Vx-722x-0-4-03	2.2	RYB-722-03	2 b
Vx-722x-0-4-04	4.4	RYB-722-04	2 b
Vx-726x-0-4-01	0.4	RYB-726-01	2 b
Vx-726x-0-4-02	1.3	RYB-726-02	2 b
Vx-726x-0-4-03	2.2	RYB-726-03	2 b
Vx-726x-0-4-04	4.4	RYB-726-04	2 b
Vx-726x-0-4-28 °	1.8	RYB-726-28	1 a
Vx-726x-0-4-30 °	2.9	RYB-726-30	1 a
Vx-726x-0-4-31 °	0.1	RYB-726-31	1 a
Vx-726x-0-4-33 °	0.22	RYB-726-33	1 a
Vx-726x-0-4-34 °	0.75	RYB-726-34	1 a
Vx-726x-0-4-36 °	1.0	RYB-726-36	1 a
Vx-726x-0-4-39 °	3.25	RYB-726-39	1 a

- a. These kits consist of one stem and plug assembly.
- b. These kits consist of one original-design plug and one enhanced-design plug. Original-design plugs include an O-ring. There is no O-ring on enhanced-design plugs. Enhanced-design valves have an O-ring in the valve seat, which must be intact and functional in order to ensure proper valve performance.
- c. Rebuild kits are not available for Vx-726x Bronze Valves with part number suffixes above 20 that have silver-colored actuator mounting nuts. These valves cannot be repaired, and must be replaced.

Vx-7xxx Bronze Globe Valves – ½” (15 mm) Rebuild Kits

3-Way

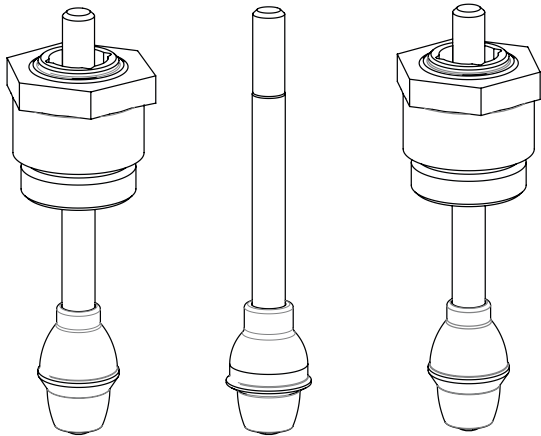

Original Design (Brass)
 Enhanced Design (Stainless Steel)
 RYB-736 (-2, -4)
 RYB-731 (-2, -4)

Note: The actual shape of the plug varies with Cv.

Valve Body	Cv	Rebuild Kit	Stem and Plug Assy
Vx-731x-0-4-02	2.2	RYB-731-02	2 b
Vx-731x-0-4-04	4.4	RYB-731-04	2 b
Vx-736x-0-4-02	2.2	RYB-736-02	1 a
Vx-736x-0-4-04	4.4	RYB-736-04	1 a

- a. These kits consist of one stem and plug assembly.
- b. These kits consist of one original-design plug and one enhanced-design plug. The original-design replacement plug is brass. The enhanced-design replacement plug is stainless steel. Enhanced-design ½” and ¾” valves must have an O-ring on the “A” port side that is intact and functional in order to ensure proper valve performance.

Vx-7xxx Accessories

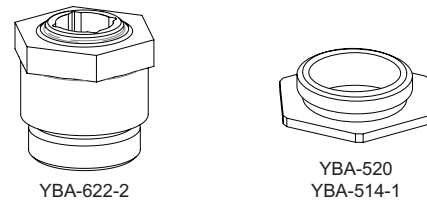

Part Number	Description
YBA-514-1 ^a	Actuator mounting nut, silver-colored (original-design valves)
YBA-520 ^a	Actuator mounting nut, gold-colored (enhanced-design valves)
NYBA-67 ^b	Grease Kit (included in Rebuild Kit RYB-732)
YBA-622-2 ^c	Packing Cartridge (included in Rebuild Kit)
YBA-622-25 ^c	Packing Cartridge, Quantity 25 with TOOL-020-1

- a. Replace the actuator mounting nut only with a like-colored nut. Do not interchange silver-colored and gold-colored mounting nuts on the valve.
- b. The grease kit is included in Plug Rebuild Kit RYB-732-xx but can be ordered separately by the part number listed in this table.
- c. The packing cartridge is included in Plug Rebuild Kit RYB-7xx-xx but can be ordered separately by the part numbers listed in this table.

Vx-7xxx Bronze Globe Valves – 3/4" (20 mm) Rebuild Kits

2-Way Normally Open

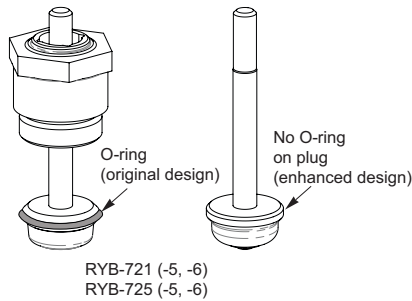

Note: The actual shape of the plug varies with Cv.

Valve Body	Cv	Rebuild Kit	Stem and Plug Assy
Vx-721x-0-x-05	5.5	RYB-721-05	2 b
Vx-721x-0-4-06	7.5	RYB-721-06	2 b c
Vx-721x-0-3-06	8.5	RYB-721-06	2 b c

- a. These kits consist of one stem and plug assembly.
- b. These kits consist of one original-design plug and one enhanced-design plug. Original-design plugs include an O-ring. There is no O-ring on enhanced-design plugs. Enhanced-design valves have an O-ring in the valve seat, which must be intact and functional in order to ensure proper valve performance.
- c. Some kits are used in more than one style valve body. In that case, the Cv capacity is determined by the combination of the plug and the valve body style.

2-Way Normally Closed

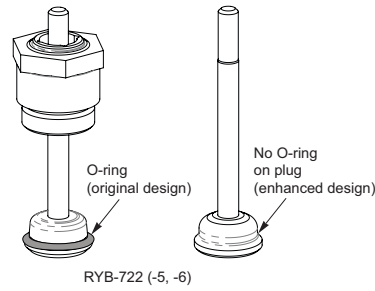

Note: The actual shape of the plug varies with Cv.

Valve Body	Cv	Rebuild Kit	Stem and Plug Assy
Vx-722x-0-4-05	5.5	RYB-722-05	2 b
Vx-722x-0-4-06	7.5	RYB-722-06	2 b
Vx-726x-0-4-41 °	6.3	RYB-726-41	1 a
Vx-726x-0-4-05	5.5	RYB-726-05	2 b
Vx-726x-0-4-06	7.5	RYB-726-06	2 b

- a. These kits consist of one stem and plug assembly.
- b. These kits consist of one original-design plug and one enhanced-design plug. Original-design plugs include an O-ring. There is no O-ring on enhanced-design plugs. Enhanced-design valves have an O-ring in the valve seat, which must be intact and functional in order to ensure proper valve performance.
- c. Rebuild kits are not available for original-design dash 41 valve bodies that have silver colored actuator mounting nuts. These valves cannot be repaired, and must be replaced.

Vx-7xxx Bronze Globe Valves – 3/4" (20 mm) Rebuild Kits

3-Way

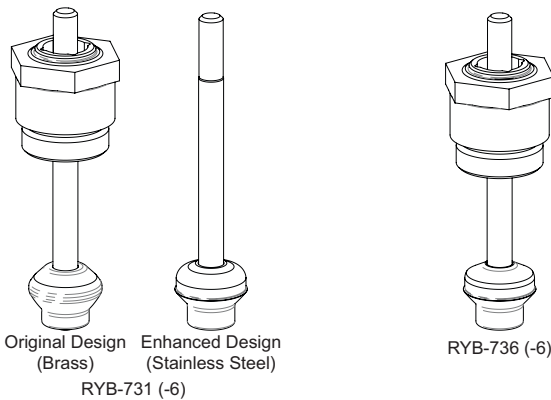

Note: The actual shape of the plug varies with Cv.

Valve Body	Cv	Rebuild Kit	Stem and Plug Assy
Vx-731x-0-4-06	7.5	RYB-731-06	2 b
Vx-732x-0-4-06	7.5	RYB-732-06	1 a
Vx-736x-0-4-06	7.5	RYB-736-06	1 a

- a. These kits consist of one stem and plug assembly.
- b. These kits consist of one original-design plug and one enhanced-design plug. The original-design replacement plug is brass. The enhanced-design replacement plug is stainless steel. Enhanced-design 1/2" and 3/4" valves must have an O-ring on the "A" port side that is intact and functional in order to ensure proper valve performance.

Vx-7xxx Accessories

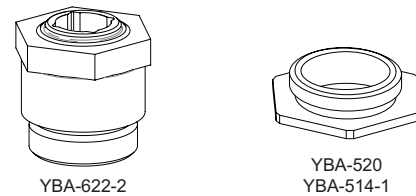

Part Number	Description
YBA-514-1 a	Actuator mounting nut, silver-colored (original-design valves)
YBA-520 a	Actuator mounting nut, gold-colored (enhanced-design valves)
NYBA-67 b	Grease Kit (included in Rebuild Kit RYB-732)
YBA-622-2 c	Packing Cartridge (included in Rebuild Kit)
YBA-622-25 c	Packing Cartridge, Quantity 25 with TOOL-020-1

- a. Replace the actuator mounting nut only with a like-colored nut. Do not interchange silver-colored and gold-colored mounting nuts on the valve.
- b. The grease kit is included in Plug Rebuild Kit RYB-732-xx but can be ordered separately by the part number listed in this table.
- c. The packing cartridge is included in Plug Rebuild Kit RYB-7xx-xx but can be ordered separately by the part numbers listed in this table.

Vx-7xxx Bronze Globe Valves – 3/4" (20 mm) Rebuild Kits

2-Way Normally Open

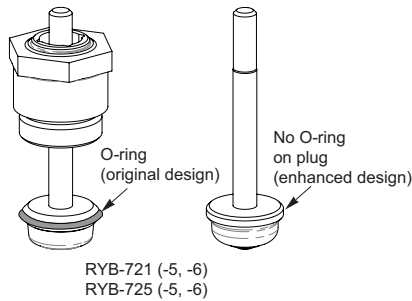

Note: The actual shape of the plug varies with Cv.

Valve Body	Cv	Rebuild Kit	Stem and Plug Assy
Vx-721x-0-x-05	5.5	RYB-721-05	2 b
Vx-721x-0-4-06	7.5	RYB-721-06	2 b c
Vx-721x-0-3-06	8.5	RYB-721-06	2 b c

- a. These kits consist of one stem and plug assembly.
- b. These kits consist of one original-design plug and one enhanced-design plug. Original-design plugs include an O-ring. There is no O-ring on enhanced-design plugs. Enhanced-design valves have an O-ring in the valve seat, which must be intact and functional in order to ensure proper valve performance.
- c. Some kits are used in more than one style valve body. In that case, the Cv capacity is determined by the combination of the plug and the valve body style.

2-Way Normally Closed

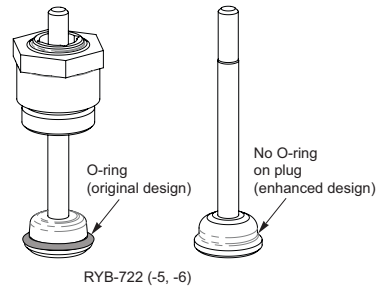

Note: The actual shape of the plug varies with Cv.

Valve Body	Cv	Rebuild Kit	Stem and Plug Assy
Vx-722x-0-4-05	5.5	RYB-722-05	2 b
Vx-722x-0-4-06	7.5	RYB-722-06	2 b
Vx-726x-0-4-41 °	6.3	RYB-726-41	1 a
Vx-726x-0-4-05	5.5	RYB-726-05	2 b
Vx-726x-0-4-06	7.5	RYB-726-06	2 b

- a. These kits consist of one stem and plug assembly.
- b. These kits consist of one original-design plug and one enhanced-design plug. Original-design plugs include an O-ring. There is no O-ring on enhanced-design plugs. Enhanced-design valves have an O-ring in the valve seat, which must be intact and functional in order to ensure proper valve performance.
- c. Rebuild kits are not available for original-design dash 41 valve bodies that have silver colored actuator mounting nuts. These valves cannot be repaired, and must be replaced.

Vx-7xxx Bronze Globe Valves – 3/4" (20 mm) Rebuild Kits

3-Way

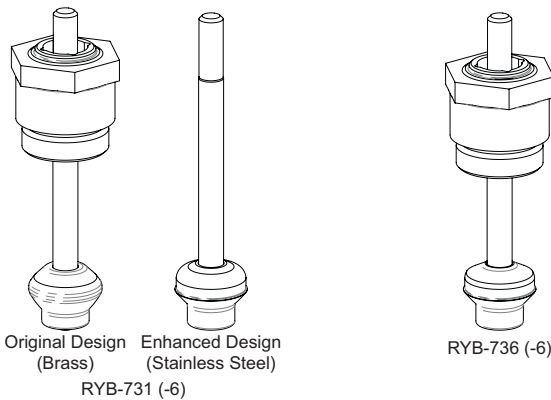

Note: The actual shape of the plug varies with Cv.

Valve Body	Cv	Rebuild Kit	Stem and Plug Assy
Vx-731x-0-4-06	7.5	RYB-731-06	2 b
Vx-732x-0-4-06	7.5	RYB-732-06	1 a
Vx-736x-0-4-06	7.5	RYB-736-06	1 a

- a. These kits consist of one stem and plug assembly.
- b. These kits consist of one original-design plug and one enhanced-design plug. The original-design replacement plug is brass. The enhanced-design replacement plug is stainless steel. Enhanced-design 1/2" and 3/4" valves must have an O-ring on the "A" port side that is intact and functional in order to ensure proper valve performance.

Vx-7xxx Accessories

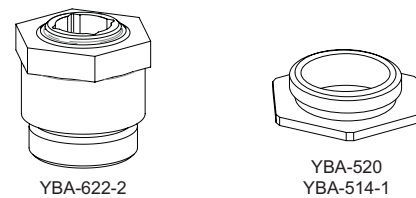

Part Number	Description
YBA-514-1 a	Actuator mounting nut, silver-colored (original-design valves)
YBA-520 a	Actuator mounting nut, gold-colored (enhanced-design valves)
NYBA-67 b	Grease Kit (included in Rebuild Kit RYB-732)
YBA-622-2 c	Packing Cartridge (included in Rebuild Kit)
YBA-622-25 c	Packing Cartridge, Quantity 25 with TOOL-020-1

- a. Replace the actuator mounting nut only with a like-colored nut. Do not interchange silver-colored and gold-colored mounting nuts on the valve.
- b. The grease kit is included in Plug Rebuild Kit RYB-732-xx but can be ordered separately by the part number listed in this table.
- c. The packing cartridge is included in Plug Rebuild Kit RYB-7xx-xx but can be ordered separately by the part numbers listed in this table.

Vx-7xxx Bronze Globe Valves – 1" (25 mm) Rebuild Kits

2-Way Normally Open

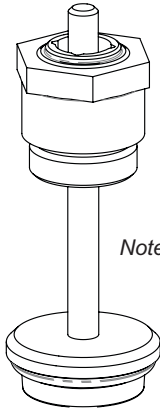

Note: The actual shape of the plug varies with Cv.

RYP-721 (-7, -8)
RYP-725 (-7, -8)

2-Way Normally Closed

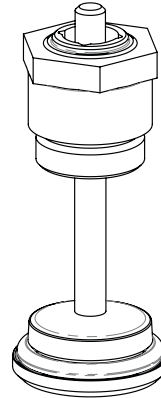

Note: The actual shape of the plug varies with Cv.

RYP-722 (-7, -8 -51, -52)

Valve Body	Cv	Rebuild Kit
Vx-7211-0-3-07	14	RYP-721-07 a
Vx-721x-0-4-07	10	RYP-721-07 a
Vx-721x-0-4-08	14	RYP-721-08

a. Some kits are used in more than one style valve body. In that case, the Cv capacity is determined by the combination of the plug and the valve body style.

Valve Body	Cv	Rebuild Kit
Vx-722x-0-4-07	10	RYP-722-07
Vx-722x-0-4-08	14	RYP-722-08
Vx-726x-0-4-51	8.2	RYP-726-51
Vx-726x-0-4-52	9	RYP-726-52
Vx-728x-0-4-08	12	

3-Way

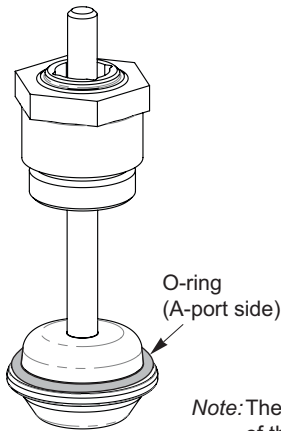

O-ring
(A-port side)

Note: The actual shape of the plug varies with Cv.

RYP-731 (-8)
RYP-736 (-8)

Valve Body	Cv	Rebuild Kit
Vx-731x-0-4-08	14	RYP-731-08 a
Vx-736x-0-4-08	12	RYP-736-08 a

a. 3-Way mixing valve rebuild kits include a plug with an O-ring on the "A" port side.

Vx-7xxx Accessories

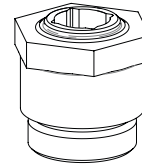

YBA-622-2

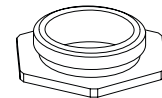

YBA-520
YBA-514-1

Part Number	Description
YBA-514-1 a	Actuator mounting nut, silver-colored
YBA-520 a	Actuator mounting nut, gold-colored
NYBA-67 b	Grease Kit (included in Rebuild Kit RYP-732)
YBA-622-2 c	Packing Cartridge (included in Rebuild Kit)
YBA-622-25 c	Packing Cartridge, Quantity 25 with TOOL-020-1

- a. Replace the actuator mounting nut only with a like-colored nut. Do not interchange silver-colored and gold-colored mounting nuts on the valve.
- b. The grease kit is included in Plug Rebuild Kit RYP-732-xx but can be ordered separately by the part number listed in this table.
- c. The packing cartridge is included in Plug Rebuild Kit RYP-7xx-xx but can be ordered separately by the part numbers listed in this table.

Vx-7xxx Bronze Globe Valves – 1¼” (32 mm) Rebuild Kits

2-Way Normally Open

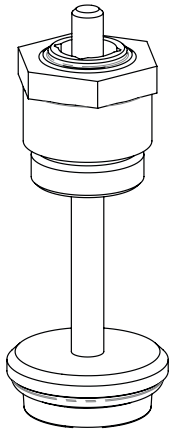

Note: The actual shape of the plug varies with Cv.

RYB-721 (-9)

Valve Body	Cv	Rebuild Kit
Vx-7211-0-3-09	22	RYB-721-09 a
Vx-721x-0-4-09	20	RYB-721-09 a

a. Some kits are used in more than one style valve body. In that case, the Cv capacity is determined by the combination of the plug and the valve body style.

2-Way Normally Closed

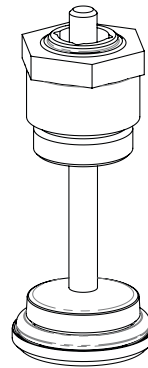

Note: The actual shape of the plug varies with Cv.

RYB-722 (-9)
RYB-726 (-61, -62, -63)

Valve Body	Cv	Rebuild Kit
Vx-722x-0-4-09	20	RYB-722-09
Vx-726x-0-4-61	14	RYB-726-61
Vx-726x-0-4-62	16	RYB-726-62
Vx-726x-0-4-63	18	RYB-726-63

3-Way

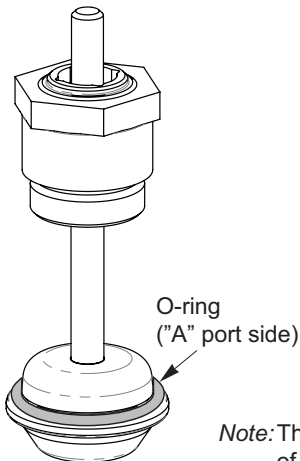

Note: The actual shape of the plug varies with Cv.

RYB-731 (-9)
RYB-736 (-9)

Valve Body	Cv	Rebuild Kit
Vx-731x-0-4-09	20	RYB-731-09 a
Vx-736x-0-4-09	20	RYB-736-09 a

a. 3-Way mixing valve rebuild kits include a plug with an O-ring on the “A” port side.

Vx-7xxx Accessories

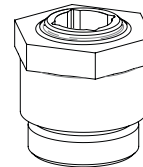

YBA-622-2

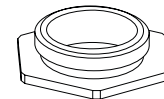

YBA-520
YBA-514-1

Part Number	Description
YBA-514-1 ^a	Actuator mounting nut, silver-colored
YBA-520 ^a	Actuator mounting nut, gold-colored
NYBA-67 ^b	Grease Kit (included in Rebuild Kit RYB-732)
YBA-622-2 ^c	Packing Cartridge (included in Rebuild Kit)
YBA-622-25 ^c	Packing Cartridge, Quantity 25 with TOOL-020-1

- a. Replace the actuator mounting nut only with a like-colored nut. Do not interchange silver-colored and gold-colored mounting nuts on the valve.
- b. The grease kit is included in Plug Rebuild Kit RYB-732-xx but can be ordered separately by the part number listed in this table.
- c. The packing cartridge is included in Plug Rebuild Kit RYB-7xx-xx but can be ordered separately by the part numbers listed in this table.

Vx-7xxx Bronze Globe Valves – 1½” (40 mm) Rebuild Kits

2-Way Normally Open

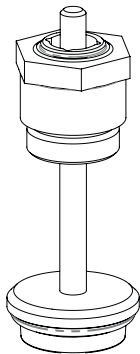

RYP-721 (-10)

Note: The actual shape of the plug varies with Cv.

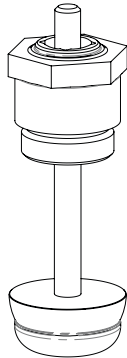

RYP-727 (-10)

Valve Body	Cv	Rebuild Kit
Vx-721x-0-4-10	28	RYP-721-10
Vx-727x-0-4-10	28	RYP-727-10

2-Way Normally Closed

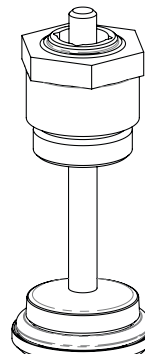

RYP-722 (-10, -71, -72)

Note: The actual shape of the plug varies with Cv.

Valve Body	Cv	Rebuild Kit
Vx-722x-0-4-10	28	RYP-722-10
Vx-726x-0-4-71	22	RYP-726-71
Vx-726x-0-4-72	24	RYP-726-72

3-Way

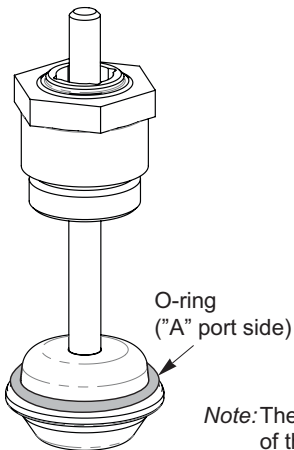

RYP-731 (-10)
RYP-736 (-10)

Note: The actual shape of the plug varies with Cv.

Valve Body	Cv	Rebuild Kit
Vx-731x-0-4-10	28	RYP-731-10 a
Vx-736x-0-4-10	28	RYP-736-10 a

a. 3-Way mixing valve rebuild kits include a plug with an O-ring on the "A" port side.

Vx-7xxx Accessories

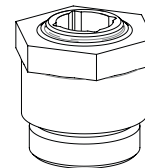

YBA-622-2

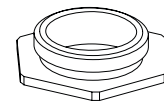

YBA-520
YBA-514-1

Part Number	Description
YBA-514-1 ^a	Actuator mounting nut, silver-colored
YBA-520 ^a	Actuator mounting nut, gold-colored
NYBA-67 ^b	Grease Kit (included in Rebuild Kit RYP-732)
YBA-622-2 ^c	Packing Cartridge (included in Rebuild Kit)
YBA-622-25 ^c	Packing Cartridge, Quantity 25 with TOOL-020-1

- a. Replace the actuator mounting nut only with a like-colored nut. Do not interchange silver-colored and gold-colored mounting nuts on the valve.
- b. The grease kit is included in Plug Rebuild Kit RYP-732-xx but can be ordered separately by the part number listed in this table.
- c. The packing cartridge is included in Plug Rebuild Kit RYP-7xx-xx but can be ordered separately by the part numbers listed in this table.

Vx-7xxx Bronze Globe Valves – 2” (50 mm) Rebuild Kits

2-Way Normally Open

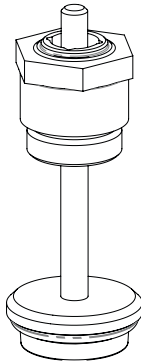

RYP-721 (-11)
RYP-725 (-11)

Note: The actual shape of the plug varies with Cv.

Valve Body	Cv	Rebuild Kit
Vx-721x-0-4-11	40	RYP-721-11
Vx-725x-0-4-11	40	RYP-725-11

2-Way Normally Closed

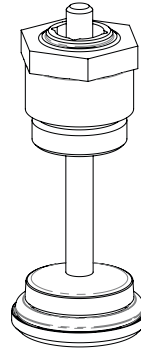

RYP-722 (-11)
RYP-726 (-11, -81, -82)

Note: The actual shape of the plug varies with Cv.

Valve Body	Cv	Rebuild Kit
Vx-722x-0-4-11	40	RYP-722-11
Vx-726x-0-4-81	31	RYP-726-81
Vx-726x-0-4-82	34	RYP-726-82

3-Way

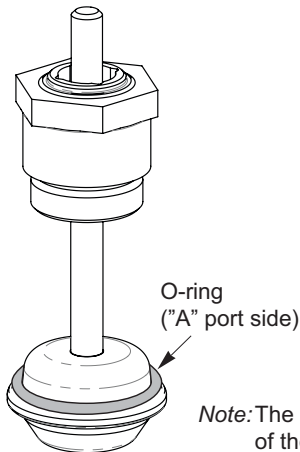

RYP-731 (-11)
RYP-736 (-11)

O-ring
("A" port side)

Note: The actual shape of the plug varies with Cv.

Valve Body	Cv	Rebuild Kit
Vx-731x-0-4-11	41	RYP-731-11 a
Vx-736x-0-4-11	36	RYP-736-11 a

a. 3-Way mixing valve rebuild kits include a plug with an O-ring on the "A" port side.

Vx-7xxx Accessories

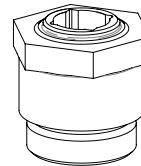

YBA-622-2

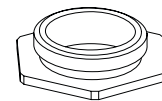

YBA-520
YBA-514-1

Part Number	Description
YBA-514-1 ^a	Actuator mounting nut, silver-colored
YBA-520 ^a	Actuator mounting nut, gold-colored
NYBA-67 ^b	Grease Kit (included in Rebuild Kit RYP-732)
YBA-622-2 ^c	Packing Cartridge (included in Rebuild Kit)
YBA-622-25 ^c	Packing Cartridge, Quantity 25 with TOOL-020-1

- a. Replace the actuator mounting nut only with a like-colored nut. Do not interchange silver-colored and gold-colored mounting nuts on the valve.
- b. The grease kit is included in Plug Rebuild Kit RYP-732-xx but can be ordered separately by the part number listed in this table.
- c. The packing cartridge is included in Plug Rebuild Kit RYP-7xx-xx but can be ordered separately by the part numbers listed in this table.

Vx-72xx Straightway Bronze Globe Valves — 1/2" and 3/4" (15 mm and 20 mm) Assembly Information

Valve Parts – 2-Way

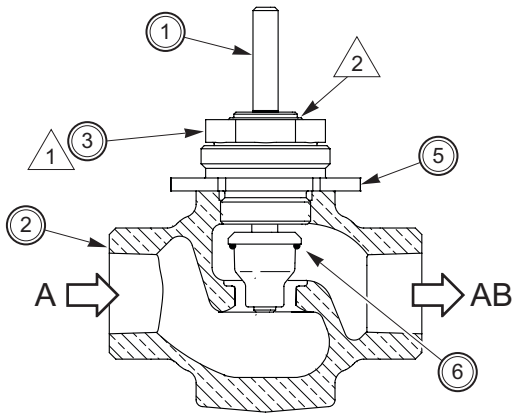

Vx-7213, Vx-7215 Series 2-Way N.O. Original-Design Straightway Bronze Globe Valves

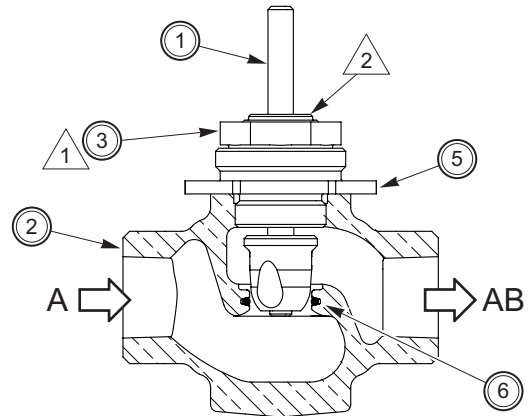

Vx-7213, Vx-7215 Series 2-Way N.O. Enhanced-Design Straightway Bronze Globe Valves

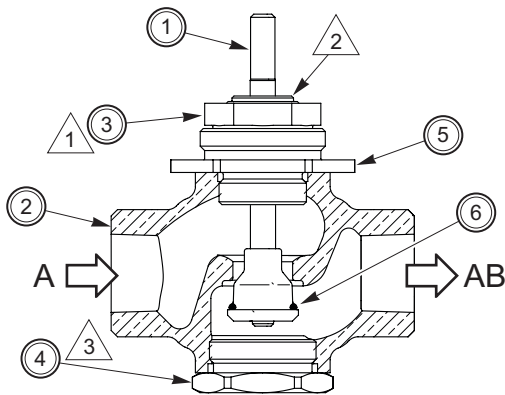

Vx-7223, Vx-7225 Series 2-Way N.C. Original-Design Straightway Bronze Globe Valves

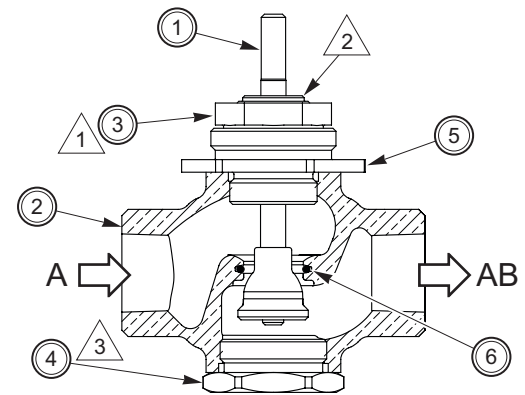

Vx-7223, Vx-7225 Series 2-Way N.C. Enhanced-Design Straightway Bronze Globe Valves

Valve ^a	Sizes	①	②	③	④	⑤	⑥
Vx-7213, Vx-7215	1/2" (15 mm) to 3/4" (20 mm)	Stem and Plug	Valve Body	Packing Cartridge	—	Actuator Lock Nut	O-ring
Vx-7223, Vx-7225					Lower Threaded Cap		

a. The listed valve models are typical of all end connection styles available with 2-way bronze-seated straightway valves.

Assembly Notes

- ① Apply Loctite pipe sealant #592 or equivalent on the threads of the packing cartridge (part of item 3) and then torque the cartridge 35 to 50 lb-ft (47 to 68 Nm).
- ② Torque the packing top (part of item 3) 12 to 20 lb-ft (16 to 27 Nm), using wrench TOOL-20-1.
- ③ Apply Loctite pipe sealant #592 or equivalent on the threads of the lower threaded cap (item 4) and then tighten to the torque shown in the Assembly Torques table.

Assembly Torques

Valve Size	Lower Threaded Cap
1/2" (15 mm)	70 to 100 lb-ft (95 to 136 Nm)
3/4" (20 mm)	90 to 130 lb-ft (122 to 176 Nm)

Vx-73x3, Vx-73x5 3-Way Bronze Globe Valves — 1/2" and 3/4" (15 mm and 20 mm) Assembly Information

Valve Parts – 3-Way

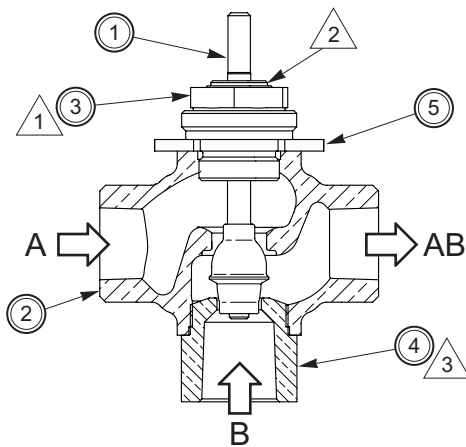

Vx-7313, Vx-7315 Series 3-Way Mixing Original-Design Bronze Globe Valves

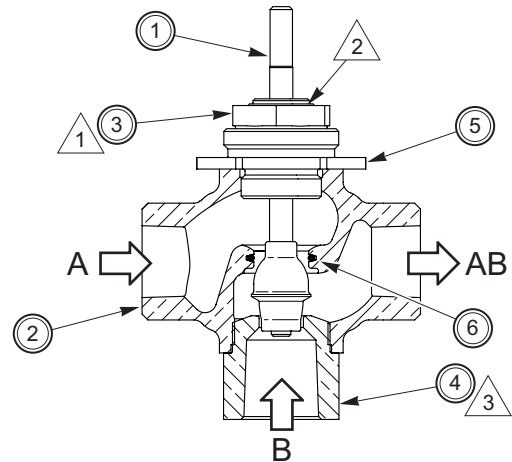

Vx-7313, Vx-7315 Series 3-Way Mixing Enhanced-Design Bronze Globe Valves

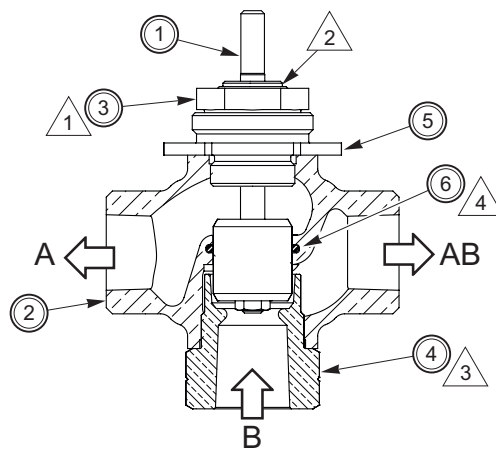

Vx-7323, Vx-7325 Series 3-Way Diverting Bronze Globe Valves

Valve	Sizes	①	②	③	④	⑤	⑥
Vx-7313, Vx-7315	1/2" (15 mm) to 3/4" (20 mm)	Stem and Plug	Valve Body	Packing Cartridge	Seat (Bottom Inlet Port)	Actuator Lock Nut	Wiper O-ring
Vx-7323, Vx-7325					Seat (Inlet Port)		

a. The listed valve models are typical of all end connection styles available with 3-way bronze-seated valves.

Assembly Notes

- ① Apply Loctite pipe sealant #592 or equivalent on the threads of the packing cartridge (part of item 3) and then torque the cartridge 35 to 50 lb-ft (47 to 68 Nm).
- ② Torque the packing top (part of item 3) 12 to 20 lb-ft (16 to 27 Nm), using wrench TOOL-20-1.
- ③ Apply Loctite pipe sealant #592 or equivalent on the threads of the seat (bottom inlet port) (item 4) or seat (inlet port) (item 4) and then tighten to the torque shown in the Assembly Torques table.
- ④ Apply silicone grease (NYBA-67 Grease Kit, part of valve rebuild kit) on a new wiper O-ring (item 6) before installing the O-ring into the valve body.

Assembly Torques

Valve Size	Seat (Bottom Inlet Port) or Seat (Inlet Port)
1/2" (15 mm)	70 to 100 lb-ft (95 to 136 Nm)
3/4" (20 mm)	90 to 130 lb-ft (122 to 176 Nm)

Vx-725x, Vx-726x, Vx-727x, and Vx-728x Stainless Steel Trim Straightway Bronze Globe Valves — 1/2" and 3/4" (15 mm and 20 mm) Assembly Information

Valve Parts – 2-Way

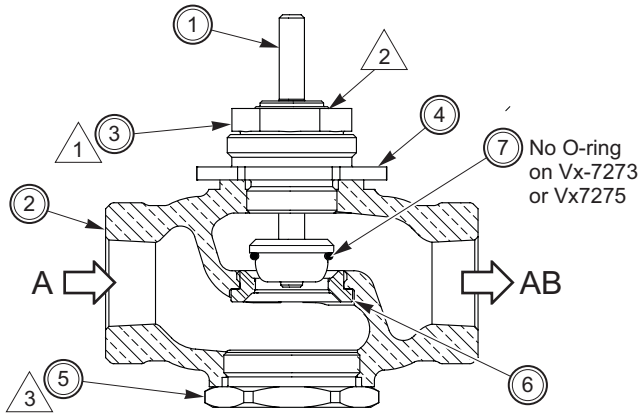

Vx-7253, Vx-7255, Vx-7273, Vx-7275 Series 2-Way N.O. Stainless Steel Trim Original-Design Straightway Bronze Globe Valves

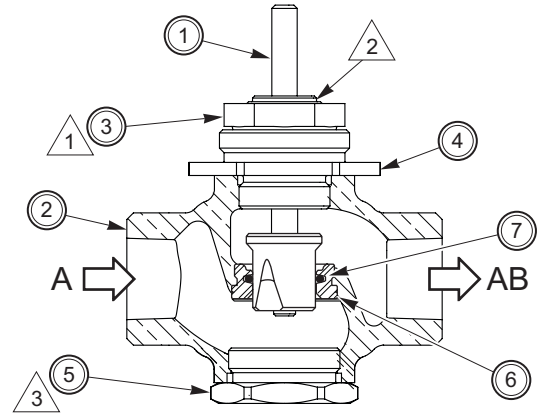

Vx-7253, Vx-7255, Vx-7273, Vx-7275 Series 2-Way N.O. Stainless Steel Trim Enhanced-Design Straightway Bronze Globe Valves

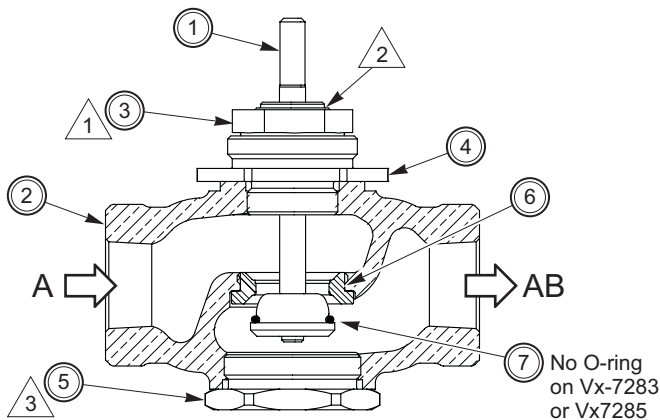

Vx-7263, Vx-7265, Vx-7283, Vx-7285 Series 2-Way N.C. Stainless Steel Trim Original-Design Straightway Bronze Globe Valves

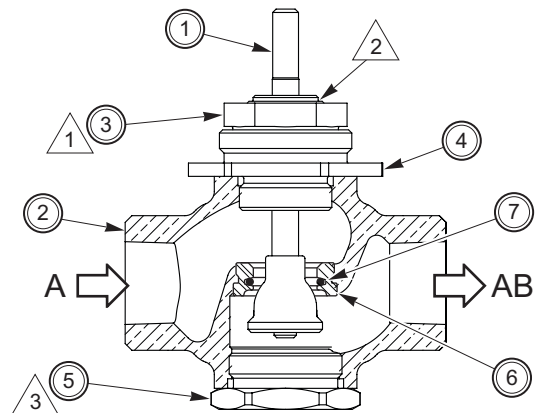

Vx-7263, Vx-7265, Vx-7283, Vx-7285 Series 2-Way N.C. Stainless Steel Trim Enhanced-Design Straightway Bronze Globe Valves

Valve ^a	Sizes	①	②	③	④	⑤	⑥	⑦
Vx-7253, Vx-7255	1/2" (15 mm) to 3/4" (20 mm)	Stem and Plug	Valve Body	Packing Cartridge	Actuator Lock Nut	Lower Threaded Cap	Seat (Stainless Steel)	O-ring
Vx-7263, Vx-7265								—
Vx-7273, Vx-7275								—
Vx-7283, Vx-7285								—

a. The listed valve models are typical of all end connection styles available with 2-way stainless steel trim straightway valves.

Assembly Notes

- ① Apply Loctite pipe sealant #592 or equivalent on the threads of the packing cartridge (part of item 3) and then torque the cartridge 35 to 50 lb-ft (47 to 68 Nm).
- ② Torque the packing top (part of item 3) 12 to 20 lb-ft (16 to 27 Nm), using wrench TOOL-20-1.
- ③ Apply Loctite pipe sealant #592 or equivalent on the threads of the lower threaded cap (item 5) and then tighten to the torque shown in the Assembly Torques table.

Assembly Torques

Valve Size	Lower Threaded Cap
1/2" (15 mm)	70 to 100 lb-ft (95 to 136 Nm)
3/4" (20 mm)	90 to 130 lb-ft (122 to 176 Nm)

Vx-72xx Straightway Bronze Globe Valves — 1" to 2" (25 mm to 50 mm)

Assembly Information

Valve Parts — 2-Way

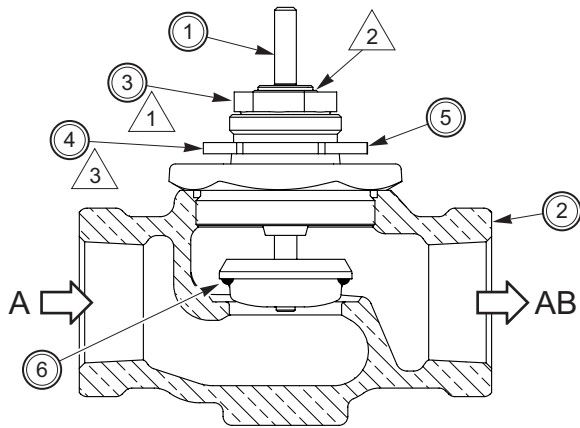

Vx-7213, Vx-7215 Series 2-Way N.O. Original-Design Straightway Bronze Globe Valves

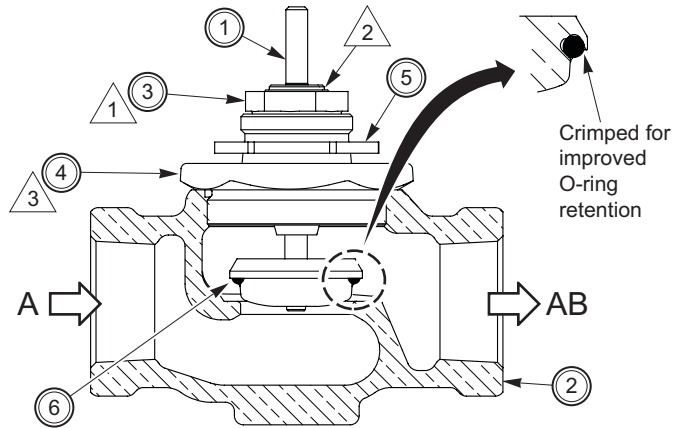

Vx-7213, Vx-7215 Series 2-Way N.O. Enhanced-Design Straightway Bronze Globe Valves

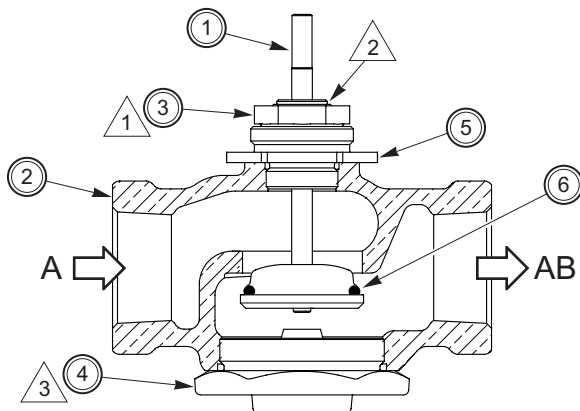

Vx-7223, Vx-7225 Series 2-Way N.C. Original-Design Straightway Bronze Globe Valves

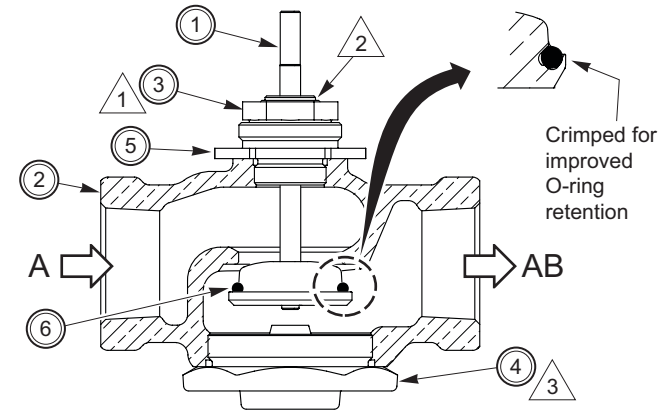

Vx-7223, Vx-7225 Series 2-Way N.C. Enhanced-Design Straightway Bronze Globe Valves

Valve ^a	Sizes	①	②	③	④	⑤	⑥
Vx-7213, Vx-7215	1" (25 mm) to 2" (50 mm)	Stem and Plug	Valve Body	Packing Cartridge	Bonnet	Actuator Lock Nut	O-ring
Vx-7223, Vx-7225					Lower Threaded Cap		

a. The listed valve models are typical of all end connection styles available with 2-way bronze-seated straightway valves.

Assembly Notes

- ① Apply Loctite pipe sealant #592 or equivalent on the threads of the packing cartridge (part of item 3) and then torque the cartridge 35 to 50 lb-ft (47 to 68 Nm).
- ② Torque the packing top (part of item 3) 12 to 20 lb-ft (16 to 27 Nm), using wrench TOOL-20-1.
- ③ Apply Loctite pipe sealant #592 or equivalent on the threads of the bonnet (item 4) or lower threaded cap (item 4) and then tighten to the torque shown in the Assembly Torques table.

Assembly Torques

Valve Size	Bonnet or Lower Threaded Cap
1" (25 mm)	110 to 160 lb-ft (149 to 217 Nm)
1-1/4" (32 mm)	120 to 190 lb-ft (163 to 258 Nm)
1-1/2" (40 mm)	140 to 210 lb-ft (190 to 285 Nm)
2" (50 mm)	180 to 280 lb-ft (244 to 380 Nm)

Vx-73x3, Vx-73x5 3-Way Bronze Globe Valves — 1" to 2" (25 mm to 50 mm)

Assembly Information

Valve Parts — 3-Way

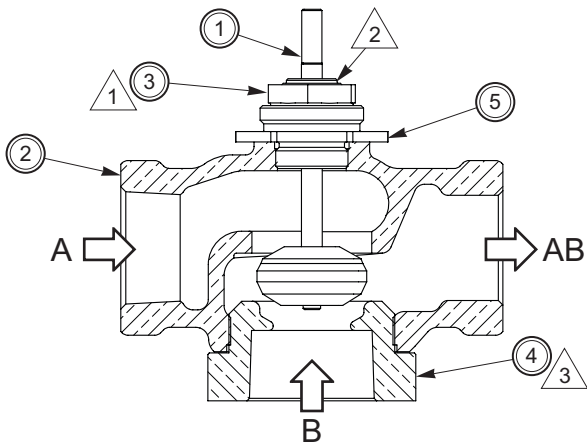

Vx-7313, Vx-7315 Series 3-Way Mixing Original-Design Bronze Globe Valves

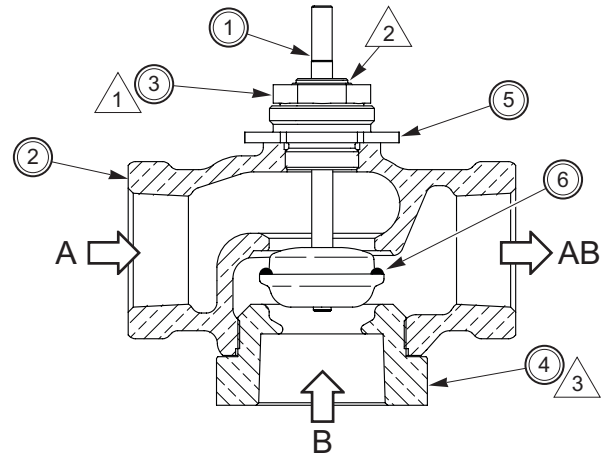

Vx-7313, Vx-7315 Series 3-Way Mixing Enhanced-Design Bronze Globe Valves

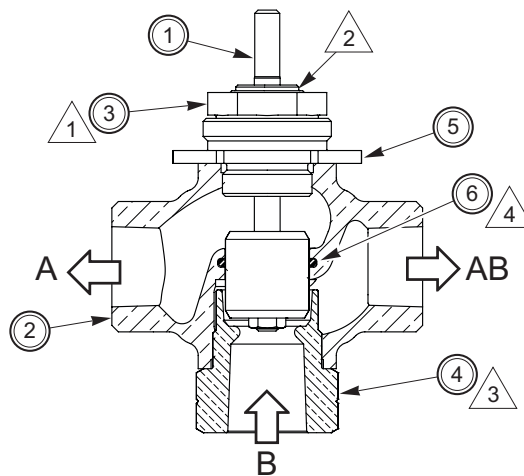

Vx-7323, Vx-7325 Series 3-Way Diverting Bronze Globe Valves

Valve	Sizes	①	②	③	④	⑤	⑥
Vx-7313, Vx-7315 Vx-7323, Vx-7325	1" (25 mm) to 2" (50 mm)	Stem and Plug	Valve Body	Packing Cartridge	Seat (Bottom Port)	Actuator Lock Nut	Wiper O-ring

a. The listed valve models are typical of all end connection styles available with 3-way bronze-seated valves.

Assembly Notes

- ① Apply Loctite pipe sealant #592 or equivalent on the threads of the packing cartridge (part of item 3) and then torque the cartridge 35 to 50 lb-ft (47 to 68 Nm).
- ② Torque the packing top (part of item 3) 12 to 20 lb-ft (16 to 27 Nm), using wrench TOOL-20-1.
- ③ Apply Loctite pipe sealant #592 or equivalent on the threads of the seat (bottom port) (item 4) and then tighten to the torque shown in the Assembly Torques table.
- ④ Apply silicone grease (NYBA-67 Grease Kit, part of valve rebuild kit) on a new wiper O-ring (item 6) before installing the O-ring into the valve body.

Assembly Torques

Valve Size	Seat (Bottom Port)
1" (25 mm)	110 to 160 lb-ft (149 to 217 Nm)
1-1/4" (32 mm)	120 to 190 lb-ft (163 to 258 Nm)
1-1/2" (40 mm)	140 to 210 lb-ft (190 to 285 Nm)
2" (50 mm)	180 to 280 lb-ft (244 to 380 Nm)

Vx-725x, Vx-726x, Vx-727x, and Vx-728x Stainless Steel Trim Straightway Bronze Globe Valves — 1" to 2" (25 mm to 50 mm)

Assembly Information

Valve Parts – 2-Way

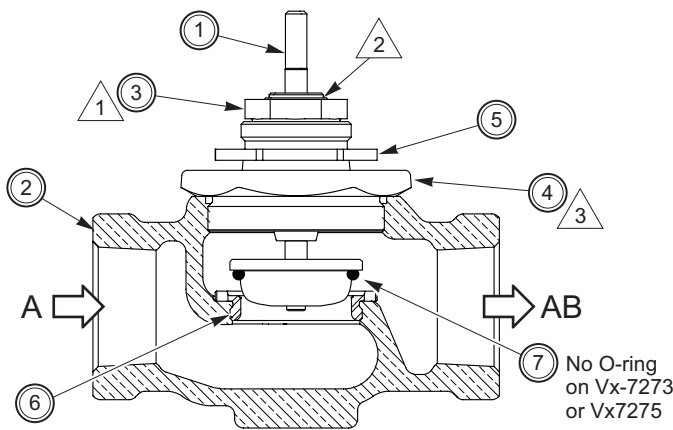

Vx-7253, Vx-7255, Vx-7273, Vx-7275 Series 2-Way N.O.
Original-Design Stainless Steel Trim Bronze Globe Valves

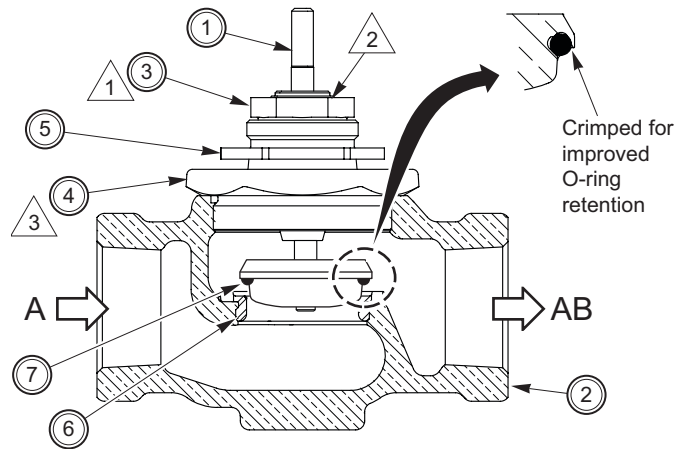

Vx-7253, Vx-7255, Vx-7273, Vx-7275 Series 2-Way N.O.
Enhanced-Design Stainless Steel Trim Bronze Globe Valves

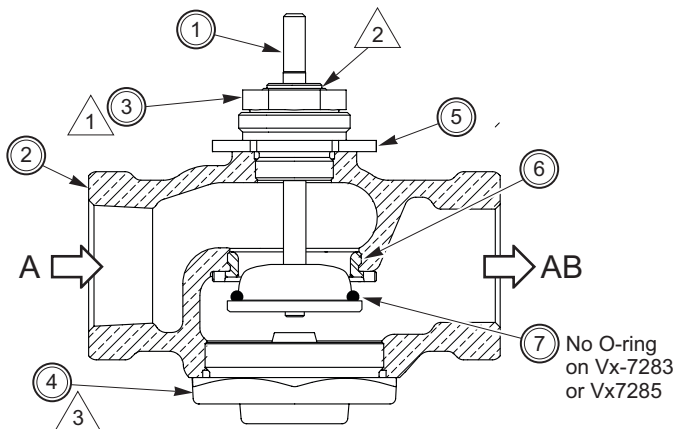

Vx-7263, Vx-7265, Vx-7283, Vx-7285 Series 2-Way N.C.
Original-Design Stainless Steel Trim Bronze Globe Valves

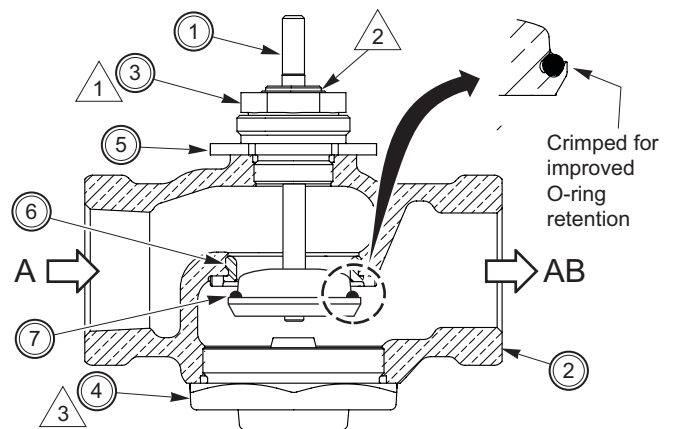

Vx-7263, Vx-7265, Vx-7283, Vx-7285 Series 2-Way N.C.
Enhanced-Design Stainless Steel Trim Bronze Globe Valves

Valve	Sizes	①	②	③	④	⑤	⑥	⑦
Vx-7253, Vx-7255	1" (25 mm) to 2" (50 mm)	Stem and Plug	Valve Body	Packing Cartridge	Bonnet	Actuator Lock Nut	Seat (Stainless Steel)	O-ring
Vx-7273, Vx-7275					—			
Vx-7263, Vx-7265					Lower Threaded Cap			O-ring
Vx-7283, Vx-7285					—			

a. The listed valve models are typical of all end connection styles available with 2-way stainless steel trim straightway valves.

Assembly Notes

- ① Apply Loctite pipe sealant #592 or equivalent on the threads of the packing cartridge (part of item 3) and then torque the cartridge 35 to 50 lb-ft (47 to 68 Nm).
- ② Torque the packing top (part of item 3) 12 to 20 lb-ft (16 to 27 Nm), using wrench TOOL-20-1.
- ③ Apply Loctite pipe sealant #592 or equivalent on the threads of the bonnet (item 4) or the lower threaded cap (item 4) and then tighten to the torque shown in the Assembly Torques table.

Assembly Torques

Valve Size	Bonnet or Lower Threaded Cap
1" (25 mm)	110 to 160 lb-ft (149 to 217 Nm)
1-1/4" (32 mm)	120 to 190 lb-ft (163 to 258 Nm)
1-1/2" (40 mm)	140 to 210 lb-ft (190 to 285 Nm)
2" (50 mm)	180 to 280 lb-ft (244 to 380 Nm)

Vx-7xxx Series Globe Valves — 1/2” to 2” (15 mm to 50 mm) Reference Information

Valve Body Rebuild Kit Chart

Valve Type	Valve Series	Description	Size	RYB Rebuild Kit	
2-Way	Vx-7211-0-3-xx	Stem Up Open (N.O.), Union Angled	1/2” to 1-1/4”	RYB-721-xx	
	Vx-7211-0-4-xx	Stem Up Open (N.O.), Union NPT	1/2” to 1-1/4”	RYB-721-xx	
	Vx-7221-0-4-xx	Stem Up Closed (N.C.), Union NPT	1/2” to 1-1/4”	RYB-722-xx	
	Vx-7212-0-4-xx	Stem Up Open (N.O.), SAE Flared	1/2”	RYB-721-xx	
	Vx-7222-0-4-xx	Stem Up Closed (N.C.), SAE Flared	1/2”	RYB-722-xx	
	Vx-7213-0-4-xx	Stem Up Open (N.O.), NPT Threaded	1/2” to 2”	RYB-721-xx	
	Vx-7215-0-4-xx	Stem Up Open (N.O.), Metric Threaded	15 mm to 50 mm	RYB-721-xx	
	Vx-7223-0-4-xx	Stem Up Closed (N.C.), NPT Threaded	1/2” to 2”	RYB-722-xx	
	Vx-7225-0-4-xx	Stem Up Closed (N.C.), Metric Threaded	15 mm to 50 mm	RYB-722-xx	
	Vx-7214-0-4-xx	Stem Up Open (N.O.), Union Sweat	1/2” to 2”	RYB-721-xx	
	Vx-7224-0-4-xx	Stem Up Closed (N.C.), Union Sweat	1/2” to 2”	RYB-722-xx	
	Vx-7251-0-3-xx	Stem Up Open (N.O.), Union Angled, Stainless Steel Trim	1/2” to 1-1/4”	RYB-725-xx	
	Vx-7251-0-4-xx	Stem Up Open (N.O.), Union, Stainless Steel Trim	1/2” to 1-1/4”	RYB-725-xx	
	Vx-7253-0-4-xx	Stem Up Open (N.O.), NPT Threaded, Stainless Steel Trim	1/2” to 2”	RYB-725-xx	
	Vx-7255-0-4-xx	Stem Up Open (N.O.), Metric Threaded, Stainless Steel Trim	15 mm to 50 mm	RYB-725-xx	
	Vx-7263-0-4-xx	Stem Up Closed (N.C.), NPT Threaded, Stainless Steel Trim	1/2” to 2”	RYB-726-xx	
	Vx-7265-0-4-xx	Stem Up Closed (N.C.), Metric Threaded, Stainless Steel Trim	15 mm to 50 mm	RYB-726-xx	
	Vx-7273-0-4-xx	Stem Up Open (N.O.), NPT Threaded, Stainless Steel Trim, Metal-to-Metal Seats	1/2” to 2”	RYB-727-xx	
	Vx-7275-0-4-xx	Stem Up Open (N.O.), Metric Threaded, Stainless Steel Trim, Metal-to-Metal Seats	15 mm to 50 mm	RYB-727-xx	
	Vx-7283-0-4-xx	Stem Up Closed (N.C.), NPT Threaded, Stainless Steel Trim, Metal-to-Metal Seats	1/2” to 2”	RYB-728-xx	
	Vx-7285-0-4-xx	Stem Up Closed (N.C.), Metric Threaded, Stainless Steel Trim, Metal-to-Metal Seats	15 mm to 50 mm	RYB-728-xx	
	3-Way	Vx-7312-0-4-xx	Stem Up B to AB, Mixing, SAE Flared	1/2”	RYB-731-xx
		Vx-7332-0-4-xx	Sequencing, SAE Flared	1/2”	—
Vx-7313-0-4-xx		Stem Up B to AB, Mixing, NPT Threaded	1/2” to 2”	RYB-731-xx	
Vx-7315-0-4-xx		Stem Up B to AB, Mixing, Metric Threaded	15 mm to 50 mm	RYB-731-xx	
Vx-7314-0-4-xx		Stem Up B to AB, Mixing, Union Sweat	1/2” to 2”	RYB-731-xx	
Vx-7323-0-4-xx		Stem Up B to AB, Diverting, NPT Threaded	1/2” to 2”	RYB-732-xx	
Vx-7325-0-4-xx		Stem Up B to AB, Diverting, Metric Threaded	15 mm to 50 mm	RYB-732-xx	
Vx-7363-0-4-xx		Stem Up B to AB, Mixing, NPT Threaded, Stainless Steel Trim	1/2” to 2”	RYB-736-xx	

Vx-8xx3 and Vx-9xx3 Flanged Body Globe Valves — 2-1/2" to 6" Rebuild Procedure

Disassembly

Disassemble the valve in preparation for rebuild kit installation:

1. If the valve is part of a valve assembly (with actuator), remove the actuator and linkage from the valve.

Depressurize the valve to 0 psig before loosening or removing a packing cartridge. Loosening or removing the packing cartridge while the valve is pressurized may cause the valve packing to blow out, thereby inflicting bodily injury or causing hardware damage to the water or steam system.

2. Loosen the packing top nut.
3. Remove the packing cartridge.
4. On Vx-8xx3 valves, remove the valve seat assembly. Check whether a gasket or an O-ring is used to seal the valve seat assembly to the valve body. A gasket is used in original-design valves, while an O-ring is used in enhanced-design valves.
5. On Vx-9xx3 valves, remove the cover plate (2-way valves) or lower port (3-way valves). Check whether a gasket or an O-ring is used to seal the cover plate or lower port to the valve body. A gasket is used in original-design valves, while an O-ring is used in enhanced-design valves.
6. Remove the valve stem and plug assembly from the valve body.
7. Check the O-ring or seat for any damage:

Vx-8xx3 valves—Inspect the O-ring on the contour seat (part of the valve seat assembly) to ensure there are no nicks or other damage. This O-ring is not field-replaceable. If this O-ring is missing or damaged, replace the valve seat assembly. If this O-ring is in good condition, rebuild the valve, using the appropriate rebuild kit.

Vx-9xx3 valves—Inspect the valve seat to ensure there are no nicks or other damage. Valves with damaged seats cannot be restored for service using a valve rebuild kit.
8. On Vx-8xx3 valves, remove the wiper O-ring from the interior of the valve body.

Reassembly

Reassemble the valve, using the rebuild kit:

9. On Vx-8213, Vx-8223, and Vx-8303 valves, coat a new wiper O-ring with the silicone grease supplied in the rebuild kit and then install the O-ring into the valve body.
10. Install the new stem and plug assembly into the valve body.
11. On Vx-8xx3 valves, use a new valve seat assembly if inspection at disassembly showed damage to the O-ring on the contour seat.
12. Install the new packing cartridge:

Refer to the YBA-652-2 Valve Packing Kits Installation Instructions, F-24185 (included with the packing kit).

Vx-8213 and Vx-8303 valves—Install the new packing cartridge onto the valve body.

Vx-8223 valves—Install the new packing cartridge onto the cover plate (part of valve seat assembly).

Vx-9213 valves—Install the new packing cartridge onto the valve body cover plate.

Vx-9223 and Vx-9313 valves—Install the new packing cartridge onto the valve body.
13. On Vx-8213, Vx-8223, and Vx-8303 valves, install the valve seat assembly, using a new gasket or O-ring to replace the type of seal found during disassembly. Fasten the valve seat assembly to the valve body using the nuts removed at disassembly and then torque 100 to 140 lb-ft (136 to 190 Nm).
14. On Vx-9213, Vx-9223, and Vx-9313 valves, reinstall the cover plate (2-way valves) or lower port (3-way valves), using a new gasket or O-ring to replace the type of seal found during disassembly. Fasten the cover plate or lower port to the valve body using the bolts or nuts removed at disassembly and then torque 100 to 140 lb-ft (136 to 190 Nm).
15. If the valve is part of a valve assembly, reinstall the actuator and linkage according to instructions in the applicable literature.
16. Check the valve and actuator for proper operation and then return to service.

Vx-8xx3 Flanged Body Iron Globe Valves (Blue Finish) — 2-1/2" to 6" Rebuild Kits

2-Way Stem Up Open

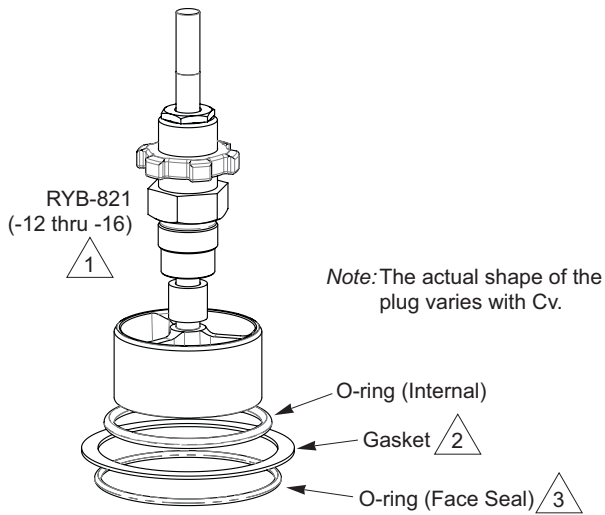

Valve Body	Size	Cv	Rebuild Kit
Vx-8213-0-5-12	2-1/2"	56	RYB-821-12
Vx-8213-0-5-13	3"	85	RYB-821-13
Vx-8213-0-5-14	4"	145	RYB-821-14
Vx-8213-0-5-15	5"	240	RYB-821-15
Vx-8213-0-5-16	6"	370	RYB-821-16

2-Way Stem Up Closed

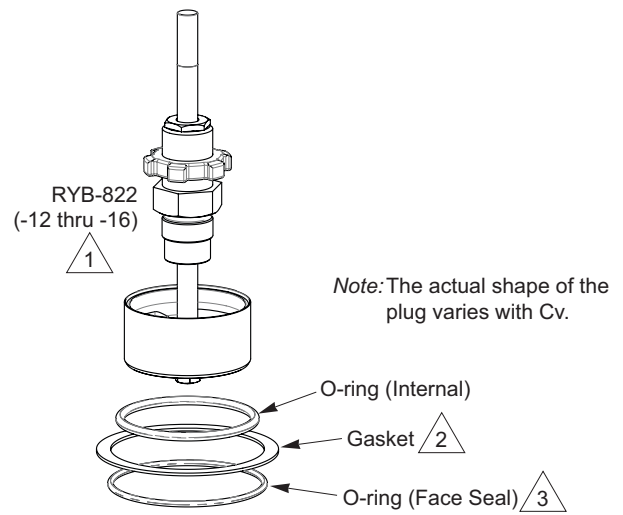

Valve Body	Size	Cv	Rebuild Kit
Vx-8223-0-5-12	2-1/2"	56	RYB-822-12
Vx-8223-0-5-13	3"	85	RYB-822-13
Vx-8223-0-5-14	4"	145	RYB-822-14
Vx-8223-0-5-15	5"	240	RYB-822-15
Vx-8223-0-5-16	6"	370	RYB-822-16

3-Way

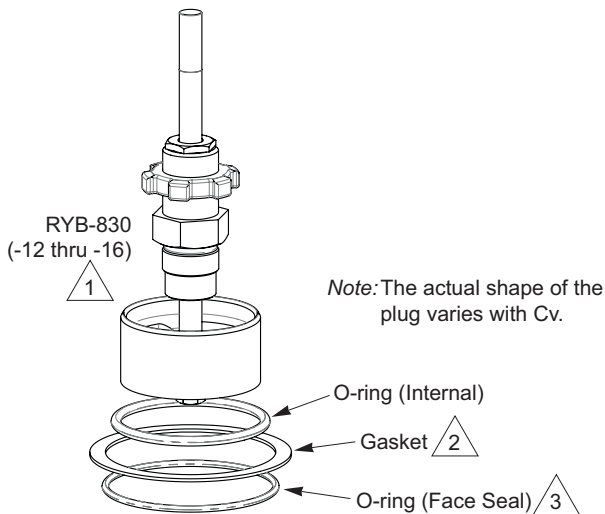

Valve Body	Size	Cv	Rebuild Kit
Vx-8303-0-5-12	2-1/2"	80 ^a	RYB-830-12
		95 ^b	
		115 ^c	
Vx-8303-0-5-13	3"	110 ^a	RYB-830-13
		120 ^{b,c}	
Vx-8303-0-5-14	4"	190	RYB-830-14
Vx-8303-0-5-15	5"	290	RYB-830-15
Vx-8303-0-5-16	6"	500	RYB-830-16

a. Mixing configuration, flow from either A or B port to AB port.
 b. Diverting configuration, flow from AB port to A port.
 c. Diverting configuration, flow from AB port to B port.

Notes

<p>1 Includes Grease Kit NYBA-67.</p> <p>2 Use gasket only with original-design valves.</p>	<p>3 Use O-ring only with enhanced-design valves</p>
---	---

Vx-8xx3 Flanged Body Iron Globe Valves (Blue Finish) — 2-1/2” to 6” Rebuild Kits

Vx-8xx3 Accessories

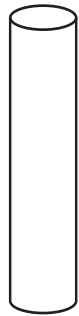

NYBA-67

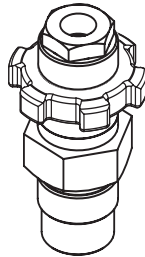

YBA-652-2

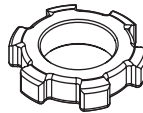

OYBB-225

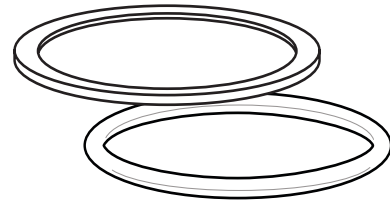

BYRZ-197-1x-KIT



NYBA-8303-104-0-1x

Part Number	Description
BYRZ-197-1x-KIT ^a	O-ring (Face Seal) and Gasket Kit
NYBA-67 ^a	Grease Kit
NYBA-8303-104-0-1x ^a	O-ring (Internal)

Part Number	Description
OYBB-225 ^a	Bracket Nut
YBA-652-2 ^a	Packing Cartridge with 1-1/4” Bracket Nut

^a. Provided with the RYB-8xx-xx rebuild kit but may be ordered separately.

Vx-8xx3 Valve Seat Assemblies

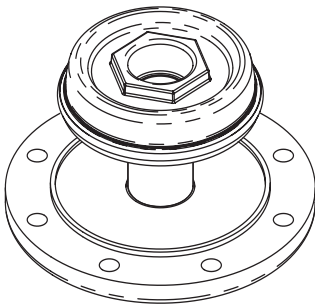

YBA-821-101-0-1x
(-12 through -16)

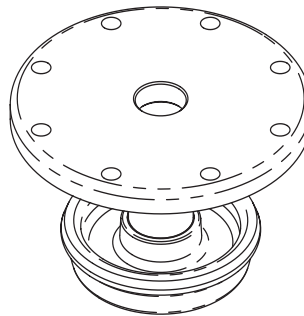

YBA-822-101-0-1x
(-12 through -16)

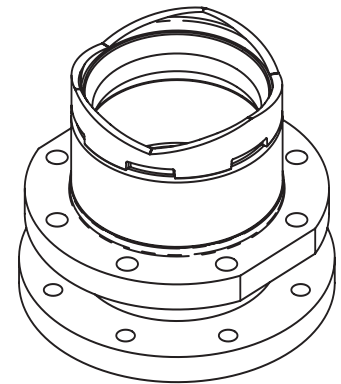

YBA-830-101-0-1x
(-12 through -16)

2-Way

Valve Body	Size	Valve Seat Assembly ^a
Vx-8213-0-5-12	2-1/2”	YBA-821-101-0-12
Vx-8213-0-5-13	3”	YBA-821-101-0-13
Vx-8213-0-5-14	4”	YBA-821-101-0-14
Vx-8213-0-5-15	5”	YBA-821-101-0-15
Vx-8213-0-5-16	6”	YBA-821-101-0-16
Vx-8223-0-5-12	2-1/2”	YBA-822-101-0-12
Vx-8223-0-5-13	3”	YBA-822-101-0-13
Vx-8223-0-5-14	4”	YBA-822-101-0-14
Vx-8223-0-5-15	5”	YBA-822-101-0-15
Vx-8223-0-5-16	6”	YBA-822-101-0-16

3-Way

Valve Body	Size	Valve Seat Assembly ^a
Vx-8303-0-5-12	2-1/2”	YBA-830-101-0-12
Vx-8303-0-5-13	3”	YBA-830-101-0-13
Vx-8303-0-5-14	4”	YBA-830-101-0-14
Vx-8303-0-5-15	5”	YBA-830-101-0-15
Vx-8303-0-5-16	6”	YBA-830-101-0-16

^a. Every YBA-8xx-101-0-1x Valve Seat Assembly includes a BYRZ-197-1x-KIT, which consists of an O-ring (face seal) and a gasket.

Vx-8xx3 Flanged Body Iron Globe Valves (Blue Finish) — 2-1/2” to 6” Assembly Information

Valve Parts — Vx-8xx3 Globe Valves

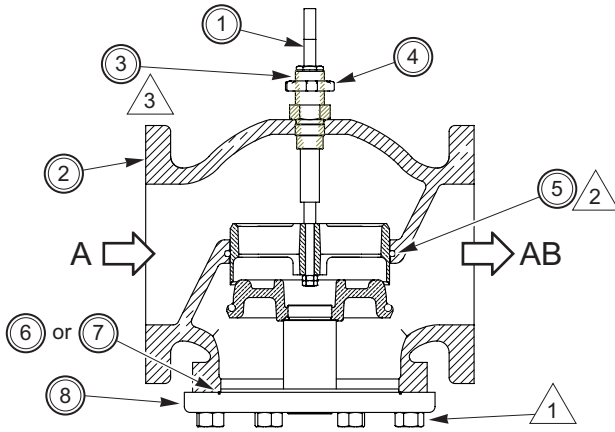

Vx-8213 Series 2-Way Stem-Up Open Globe Valves

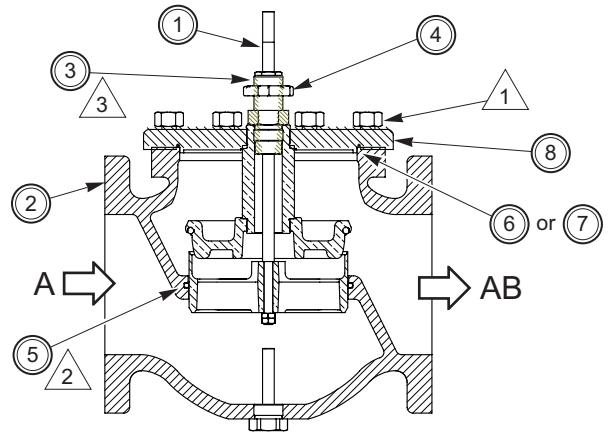

Vx-8223 Series 2-Way Stem-Up Closed Globe Valves

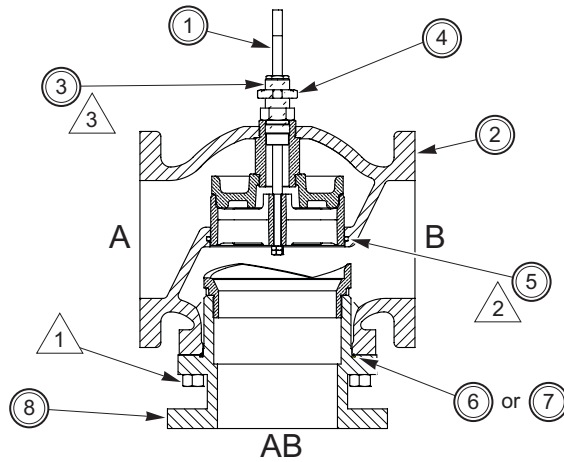

Vx-8303 Series 3-Way Globe Valves

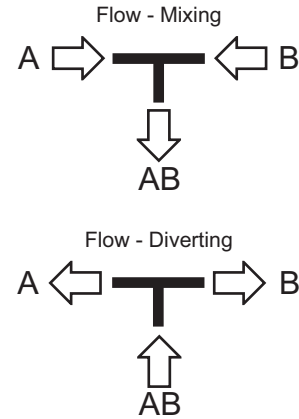

Valve	Sizes	①	②	③	④	⑤	⑥	⑦	⑧
Vx-8213 Vx-8223 Vx-8303	2-1/2” to 6”	Valve Repair Kit ^{a b}	Valve Body	Packing Cartridge	Bracket Nut	Wiper O-ring (Internal)	Gasket ^c	O-ring (Face Seal) ^d	Valve Seat Assembly ^{e f}
a. Valve Repair Kit RYB-821-1x (Vx-8213) includes: valve stem, packing cartridge, bracket nut, spacer, throttling plug, lock nut, wiper O-ring (internal) (item 5), gasket (item 6), O-ring (face seal) (item 7), and grease kit NYBA-67. b. Valve Repair Kits RYB-822-1x (Vx-8223) and RYB-830-1x (Vx-8303) include: valve stem, packing cartridge, bracket nut, throttling plug, lock nut, wiper O-ring (internal) (item 5), gasket (item 6), O-ring (face seal) (item 7), and grease kit NYBA-67.					c. Used in original design. d. Used in enhanced design with O-ring groove. e. Valve Seat Assemblies YBA-821 (Vx-8213) and YBA-822 (Vx-8223) include: contour seat, seat connector, O-ring (face seal), and cover plate. f. Valve Seat Assembly YBA-830 (Vx-8303) includes: contour seat, seat connector, O-ring (face seal), and contour seat and lower port.				

Assembly Notes

- ① Tighten nut 100 to 140 lb-ft (136 to 190 Nm).
- ② Apply silicone grease (NYBA-67 Grease Kit, part of item 1, valve repair kit) on the wiper O-ring (item 5) before installing the wiper O-ring into the groove.

- ③ Apply Loctite pipe sealant #592 or equivalent on the lower threads of the packing cartridge (part of item 3) and then torque the cartridge 40 to 70 lb-ft (54 to 95 Nm).

Vx-9xx3 Flanged Iron and Screwed Bronze Body Globe Valves (Black Finish) — 2-1/2” to 6” Rebuild Kits

2-Way Stem Up Open

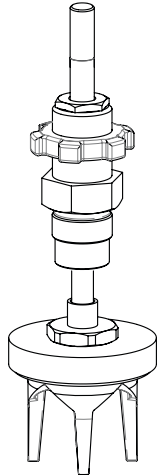

RYP-921 (-12 thru -16)

Note: The actual shape of the plug varies with Cv.

2-Way Stem Up Closed

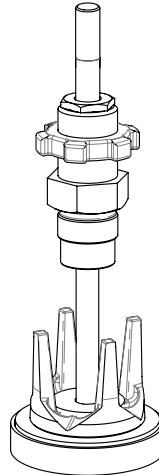

RYP-922 (-12 thru -16)

Note: The actual shape of the plug varies with Cv.

Valve Body	Size	Cv	Rebuild Kit
Vx-9213-0-4-12	2-1/2"	65	RYP-921-12 ^a
Vx-9213-0-4-13	3"	85	RYP-921-13 ^a
Vx-9213-0-5-12	2-1/2"	56	RYP-921-12 ^a
Vx-9213-0-5-13	3"	85	RYP-921-13 ^a
Vx-9213-0-5-14	4"	145	RYP-921-14
Vx-9213-0-5-15	5"	235	RYP-921-15
Vx-9213-0-5-16	6"	350	RYP-921-16

a. Some kits are used in more than one style of valve body. In that case, the Cv capacity is determined by the combination of the plug and the valve body style.

Valve Body	Size	Cv	Rebuild Kit
Vx-9223-0-4-12	2-1/2"	65	RYP-922-12 ^a
Vx-9223-0-4-13	3"	85	RYP-922-13 ^a
Vx-9223-0-5-12	2-1/2"	56	RYP-922-12 ^a
Vx-9223-0-5-13	3"	85	RYP-922-13 ^a
Vx-9223-0-5-14	4"	145	RYP-922-14
Vx-9223-0-5-15	5"	235	RYP-922-15
Vx-9223-0-5-16	6"	350	RYP-922-16

a. Some kits are used in more than one style of valve body. In that case, the Cv capacity is determined by the combination of the plug and the valve body style.

Vx-9xx3 Flanged Iron and Screwed Bronze Body Globe Valves (Black Finish) — 2-1/2” to 6”

Rebuild Kits

3-Way

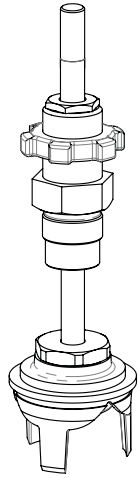

RYB-931 (-12 thru -16)

Note: The actual shape of the plug varies with Cv.

Valve Body	Size	Cv	Rebuild Kit
Vx-9313-0-4-12	2-1/2"	67	RYB-931-12 ^a
Vx-9313-0-4-13	3"	91	RYB-931-13 ^a
Vx-9313-0-5-12	2-1/2"	74	RYB-931-12 ^a
Vx-9313-0-5-13	3"	101	RYB-931-13 ^a
Vx-9313-0-5-14	4"	170	RYB-931-14
Vx-9313-0-5-15	5"	290	RYB-931-15
Vx-9313-0-5-16	6"	390	RYB-931-16

a. Some kits are used in more than one style of valve body. In that case, the Cv capacity is determined by the combination of the plug and the valve body style.

Vx-9xx3 Accessories

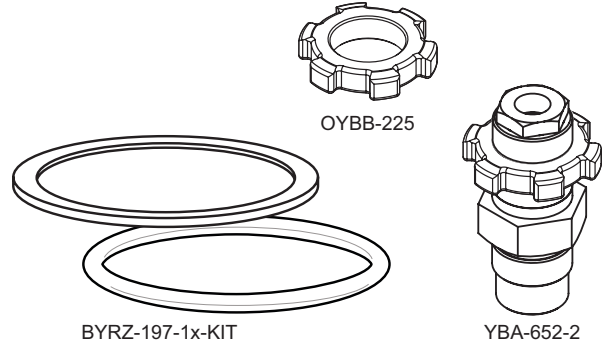

Part Number	Description
BYRZ-197-1x-KIT ^a	O-ring (Face Seal) and Gasket Kit (only used with valves having flanged cast iron body with black finish)
OYBB-225 ^b	Bracket Nut
YBA-652-2 ^b	Packing Cartridge with 1-1/4" Bracket Nut

a. The Flat Gasket or O-ring is provided with RYB-9xx-xx Rebuild Kits. If you need a replacement or additional Flat Gasket or O-ring, order Kit BYRZ-197-1x-KIT. Use either the Flat Gasket or the O-ring, as appropriate for the valve model. Use the Flat Gasket in all Vx-9213 and Vx-9223 valves. In Vx-9313 valves, examine whether a Flat Gasket or an O-ring is used on the Lower Port. Replace this part with the corresponding part from the kit.
 b. Provided with the RYB-9xx-xx Rebuild Kit but can be ordered separately.

Vx-9xx3 Flanged Iron and Screwed Bronze Body Globe Valves (Black Finish) — 2-1/2” to 6”

Assembly Information

Valve Parts — Vx-9xx3 Globe Valves

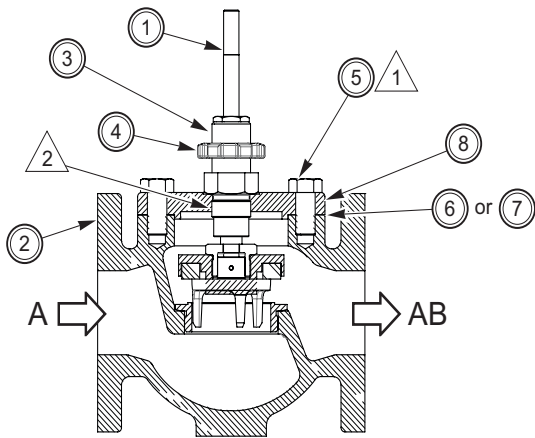

Vx-9213 Series 2-Way N.O. Globe Valves

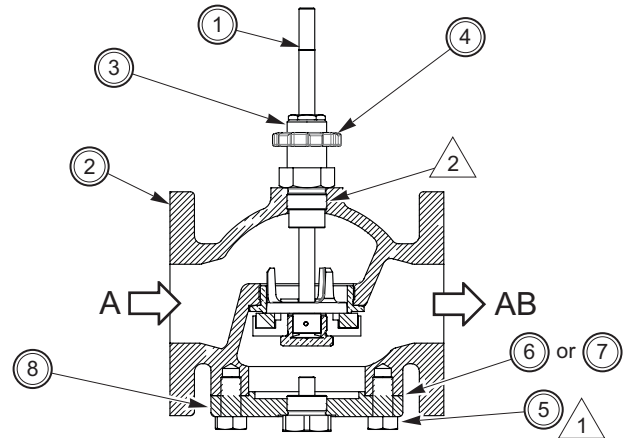

Vx-9223 Series 2-Way N.C. Globe Valves

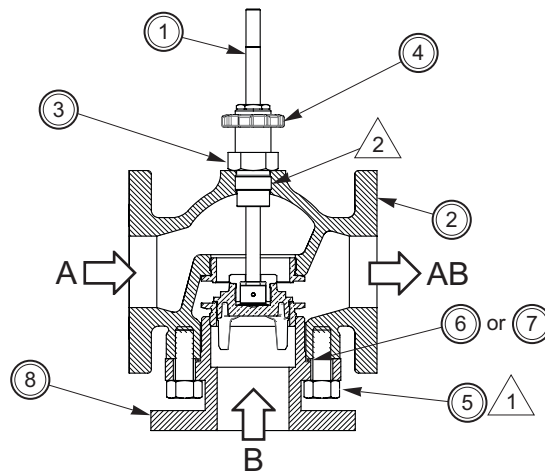

Vx-9313 Series 3-Way Mixing Globe Valves

Valve	Sizes	①	②	③	④	⑤	⑥	⑦	⑧
Vx-9213 Vx-9223	2-1/2” to 6”	Stem and Plug Assembly Kit ^{a b c}	Valve Body	Packing Cartridge	Bracket Nut	Bolt or Nut	Gasket ^d	O-ring (Face Seal) ^e	Cover Plate
Vx-9313									Lower Port
a. Stem and Plug Assembly Kit RYB-921-1x (Vx-9213) includes: stem assembly, packing cartridge, retainer nut, disc holder, disc, pin, spring, disc nut, spacer, and Grease Kit NYBA-67. b. Stem and Plug Assembly Kit RYB-922-1x (Vx-9223) includes: stem assembly, packing cartridge, disc nut, pin, disc, disc holder, retainer nut, spring, and Grease Kit NYBA-67.					c. Stem and Plug Assembly Kit RYB-931-1x (Vx-9313) includes: stem assembly, packing cartridge, pin, retainer nut, throttling plug, spring, and Grease Kit NYBA-67. d. Used in original design. e. Used in enhanced design with O-ring groove.				

Assembly Notes

<p>① Tighten nut or bolt 100 to 140 lb-ft (136 to 190 Nm).</p>	<p>② Apply Loctite pipe sealant #592 or equivalent on the lower threads of the packing cartridge (part of item 3) and then torque the cartridge as follows: Vx-9213 and Vx-9223 60 lb-ft (82 Nm) Vx-9313 40 to 70 lb-ft (54 to 95 Nm)</p>
--	---