

F780HDU, 3", 3-Way Butterfly Valve

Resilient Seat, 304 Stainless Steel Disc



Technical Data

Service	chilled, hot water, up to 60% glycol
Flow Characteristic	modified linear
Controllable Flow Range	90° rotation
Size [mm]	3" [80]
End Fitting	for use with ansi class 125/150 flanges
Body	ductile iron ASTM A536
Body Finish	epoxy powder coated
Seat	EPDM
Shaft	416 stainless steel
Bushings	RPTFE
Disc	304 stainless steel
Body Pressure Rating [psi]	200 psi at -20°F to +150°F
Number of Bolt Holes	4
Lug Threads	5/8-11 UNC
Media Temperature Range (Water)	-22°F to 250°F [-30°C to 120°C]
Close-Off Pressure	50 psi
Rangeability	10:1 (for 30° to 70° range)
Maximum Velocity	12 FPS
Cv	302
Weight	50.5 lb [22.9 kg]
Leakage	0%
Servicing	maintenance free

Application

These valves are designed to meet the needs of HVAC and commercial applications requiring bubble tight shut-off for liquids. Typical applications include chiller insulation, cooling tower isolation, change-over systems, large air handler coil control, bypass and process control applications. The large Cv values provide for an economical control valve solution for larger flow applications.

Jobsite Note

Valve assembly should be stored in a weather protected area prior to installation. Reference the butterfly valve installation instruction for additional information.

Flow/Cv								
Cv 10°	Cv 20°	Cv 30°	Cv 40°	Cv 50°	Cv 60°	Cv 70°	Cv 80°	Cv 90°
0.2	9	18	39	70	116	183	275	302

Suitable Actuators

	Non-Spring
F780HDU	GMB(X)

Dimensions (Inches [mm])

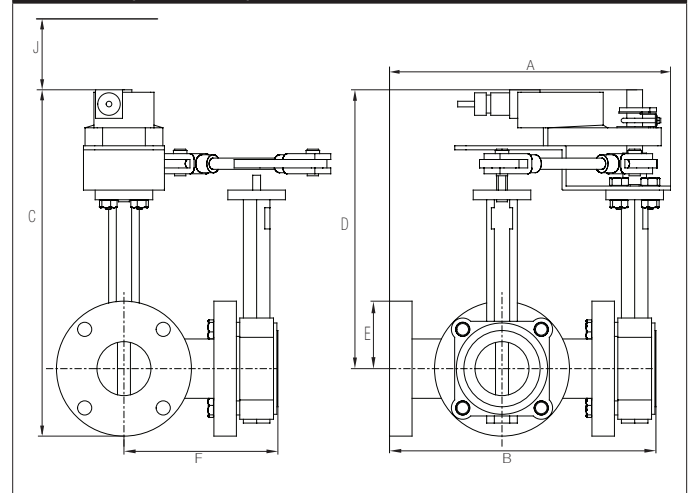

A	B	C	D	E	F	J
13.8"	12.87"	14.75"	11.5"	3.34" [85]	7.38"	3.9" [100]
[350]	[326.9]	[374.6]	[292]		[187]	

Date created, 12/07/2017 - Subject to change. © Belimo Aircontrols (USA), Inc.

GMB24-3-X1

On/Off, Floating Point, Non-Spring Return, 24 V

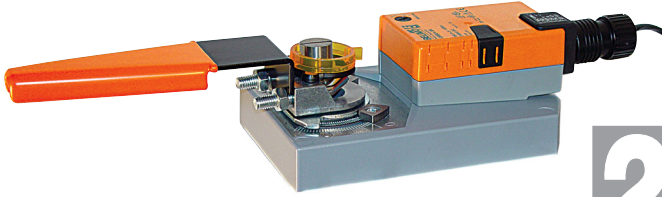

Technical Data	
Power Supply	24 VAC, ±20%, 50/60 Hz, 24 VDC, ±10%
Power Consumption Running	4 W
Power Consumption Holding	2 W
Transformer Sizing	6 VA (class 2 power source)
Electrical Connection	3ft [1m], 18 GA plenum rated cable with 1/2" conduit connector protected NEMA 2 (IP54)
Overload Protection	electronic throughout 0° to 95° rotation
Input Impedance	600 Ω
Angle of Rotation	Max. 95°, adjustable with mechanical stop
Torque motor	Min. 360 in-lbs [40 Nm]
Direction of Rotation (Motor)	reversible with built-in switch
Position Indication	reflective visual indicator (snap on)
Manual Override	external push button
Running Time (Motor)	150 sec
Ambient Humidity	5 to 95% RH non-condensing
Ambient Temperature Range	-22°F to 122°F [-30°C to 50°C]
Storage Temperature Range	-40°F to 176°F [-40°C to 80°C]
Housing	NEMA 2, IP54, UL Enclosure Type 2
Agency Listings†	cULus acc. to UL60730-1A/-2-14, CAN/CSA E60730-1:02, CE acc. to 2004/108/EC and 2006/95/EC
Noise Level (Motor)	<45 dB (A)
Servicing	maintenance free
Quality Standard	ISO 9001
Weight	4 lb [1.8 kg]

†Rated Impulse Voltage 800V, Type action 1, Control Pollution Degree 3.

Wiring Diagrams

✂️ INSTALLATION NOTES

- Ⓐ Actuators with appliance cables are numbered.
- ⚠️ 1 Provide overload protection and disconnect as required.
- ⚠️ 3 Actuators may also be powered by 24 VDC.
- ⚠️ 6 Actuators Hot wire must be connected to the control board common. Only connect common to neg. (-) leg of control circuits. Terminal models (-T) have no-feedback.
- ⚠️ 11 Actuators may be connected in parallel if not mechanically linked. Power consumption and input impedance must be observed.
- ◆ Meets cULus requirements without the need of an electrical ground connection.

⚠️ WARNING! LIVE ELECTRICAL COMPONENTS!
 During installation, testing, servicing and troubleshooting of this product, it may be necessary to work with live electrical components. Have a qualified licensed electrician or other individual who has been properly trained in handling live electrical components perform these tasks. Failure to follow all electrical safety precautions when exposed to live electrical components could result in death or serious injury.

