

# Belimo Energy Valve™

## INSTALLATION

### Inlet Length

The Energy Valve requires a section of straight pipe on the valve inlet to guarantee sensor accuracy. This section should be at least 5 pipe diameters long with respect to the size of the valve.

|            |                                      |
|------------|--------------------------------------|
| ½" [DN15]  | 5 x nominal pipe size = 2½" [64 mm]  |
| ¾" [DN20]  | 5 x nominal pipe size = 3¾" [95 mm]  |
| 1" [DN25]  | 5 x nominal pipe size = 5" [127 mm]  |
| 1¼" [DN32] | 5 x nominal pipe size = 6¼" [159 mm] |
| 1½" [DN40] | 5 x nominal pipe size = 7½" [191 mm] |
| 2" [DN50]  | 5 x nominal pipe size = 10" [254 mm] |

### Outlet Length

No requirements for outlet length.

Elbows can be installed directly after the valve.

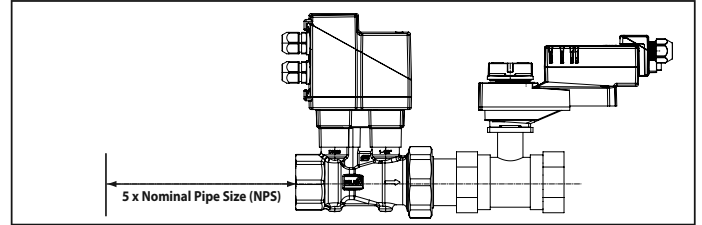

## PIPING

The Energy Valve is recommended to be installed on the return side of the coil. For ½" through 2" valves both temperature sensors are remote and are supplied with female NPT threaded pipe body. The (T2) sensor should be installed in the direction of flow after the actuator. The (T1) sensor should be installed on the other side of the coil. P/T ports are recommended on both sides of the valve and the supply side of heat transfer device to allow for pressure, flow measurement, and calculation.

It is not necessary to install one strainer per unit. Belimo recommends installing one strainer per system. If the system has multiple branches, it is recommended to install one strainer per branch.

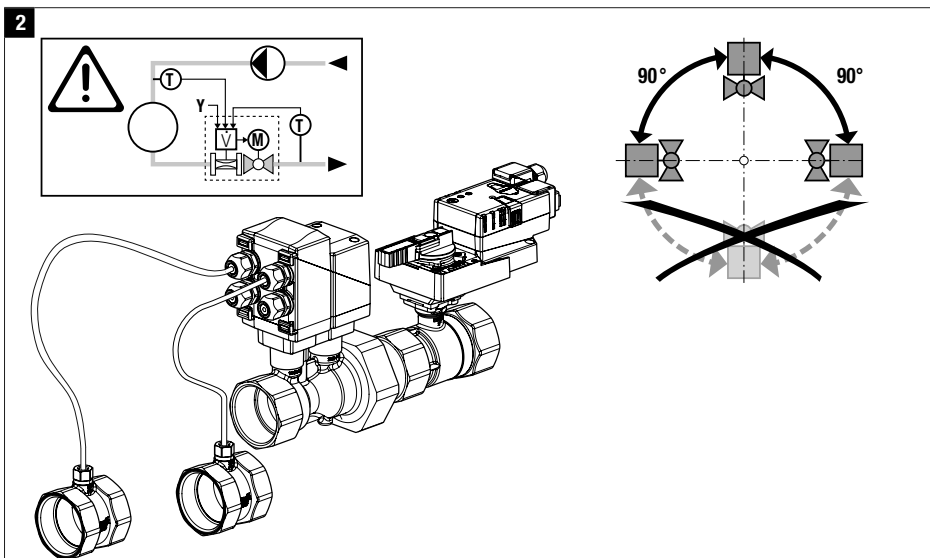
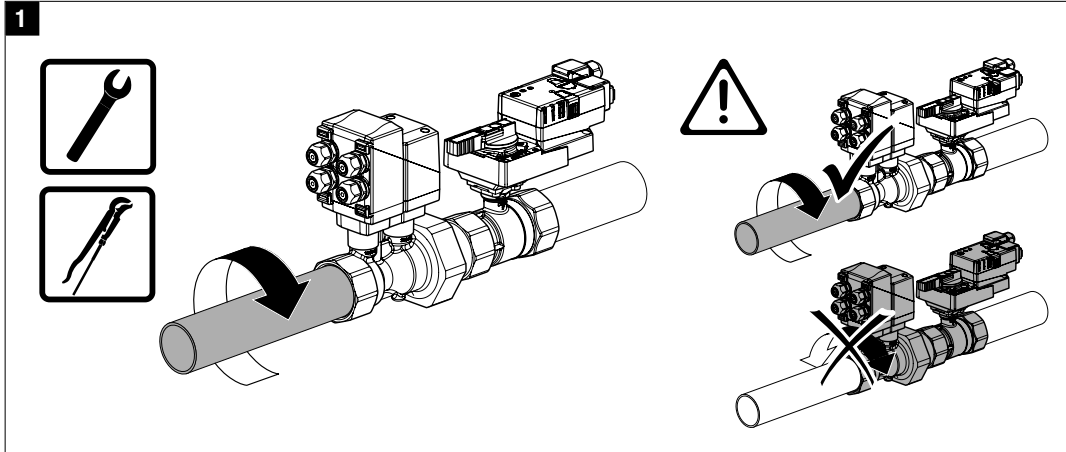

**PIPING CONTINUED**

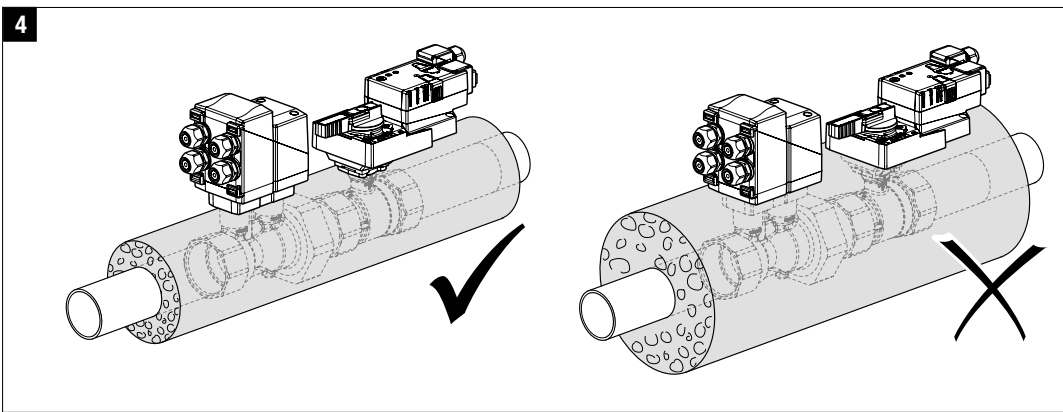
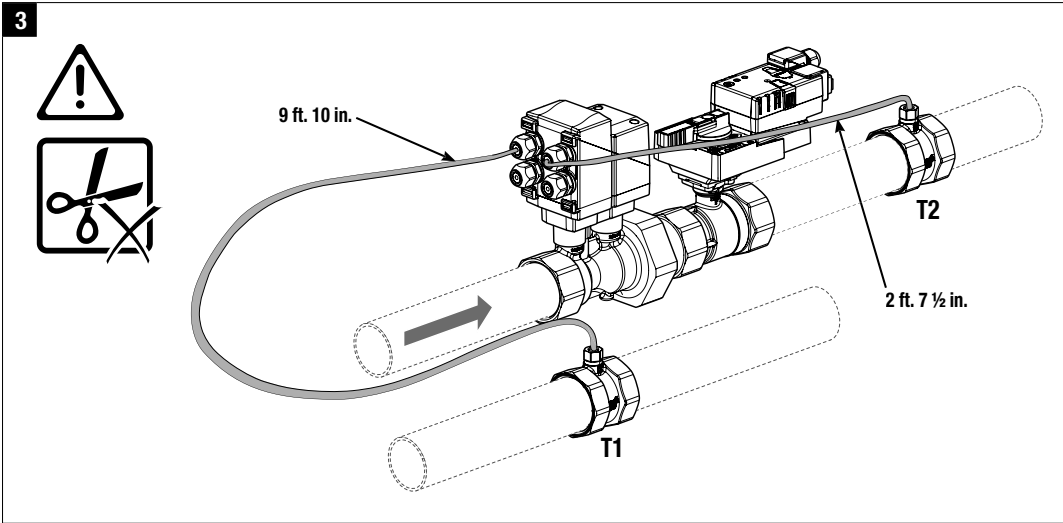

**General Warnings**

- Valve should not be used for combustible gas applications. Gas leaks and explosions may result. Do not install in systems, which exceed the ratings of the valve.
- Avoid installations where valve may be exposed to excessive moisture, corrosive fumes, vibration, high ambient temperatures, elements, or high traffic areas with potential for mechanical damage.
- Valve assembly location must be within ambient ratings of actuator. If temperature is below -14°F a heater is required.
- The valve assembly will require heat shielding, thermal isolation, or cooling if combined effect of medium and ambient temperatures – conduction, convection, and radiation – is above 122°F for prolonged time periods at the actuator.
- Visual access must be provided. Assembly must be accessible for routine schedule service. Contractor should provide unions for removal from line and isolation valves.
- Avoid excessive stresses. Mechanical support must be provided where reducers have been used and the piping system may have less structural integrity than full pipe sizes.
- Sufficient upstream piping runs must be provided to ensure proper valve capacity and flow response. See installation section for details.
- Life span of valve stems and O-rings is dependent on maintaining non-damaging conditions. Poor water treatment or filtration, corrosion, scale, other particulate can result in damage to trim components. A water treatment specialist should be consulted.

1. Inspect shipping package, valve, linkage, and actuator for physical damage. If shipping damage has occurred notify appropriate carrier. Do not install.
2. If a replacement, remove existing valve, linkage and actuator from the piping system.
3. If actuator and linkage are removed, they must be reinstalled correctly. The actuator must be rotated so that the valve seats properly for close off.
4. Install valve with the proper ports as inlets and outlets. Check that inlet and outlet of 2-way valves are correct. Flow direction arrows must be correct.
5. Blow out all piping and thoroughly clean before valve installation.
6. Clean flanges with wire brush and rag. Clean pipes, flanges, and valve flanges before installation; check for any foreign material that can become lodged in trim components. Strainers should be cleaned after initial startup.