



WALL PLATE HUMIDITY SERIES

Installation & Operation Instructions

Phone: 1-888-967-5224
Website: workaci.com

GENERAL INFORMATION

The A/RH Wall Plate Series is a Relative Humidity transmitter that can be powered with either an AC or DC supply voltage. The RH Wall Plate transmitter is field selectable with 0-5 VDC or 0-10 VDC output signal that is equivalent to 0 to 100% RH. This sensor is designed for use with electronic controllers in commercial heating and cooling building management systems. The transmitter can also include an optional temperature sensor for monitoring the space temperature.

For optimal readings, follow these tips:

- Do not install on external walls.
- Do not install near heat sources. eg: lamps, radiators, direct sunlight, copiers, chimney walls, walls concealing hot-water pipes.
- Avoid air registers, diffusers, vents, and windows.
- Avoid confined areas such as shelves, closed cabinets, closets, and behind curtains.
- Eliminate and seal all wall and conduit penetrations. Air migration from wall cavities may alter temperature readings.

MOUNTING INSTRUCTIONS

Take care when mounting. Check local code for mounting height requirements. Typical mounting heights are 48-60" (1.2 - 1.5 m) off the ground and at least 1.5' (0.5 m) from the adjacent wall. The sensor should be mounted in an area where air circulation is well mixed and not blocked by obstructions.

RH Wall Plates include a Black Rubber Cap that fits over the sensor filter. This cap should be placed on the sensor filter during wet/wash down processes.

The cap must be removed for normal operation. Plate temperature sensors (optional) are mounted on the back of a 1 Gang stainless steel plate. The foam pad will insulate the sensor from any drafts in the wall. There are (2) 6-32 x 3/4" machine screws provided for junction box mounting. Remove plastic film off stainless steel cover.

FIGURE 1: ENCLOSURE DIMENSIONS

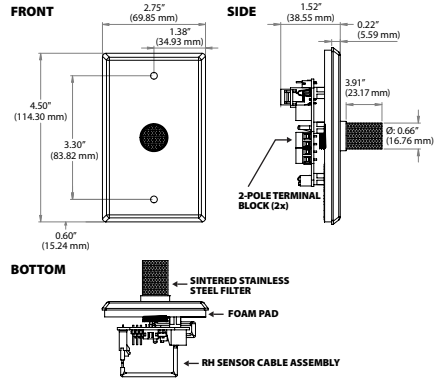

FIGURE 2: MOUNTED ASSEMBLY

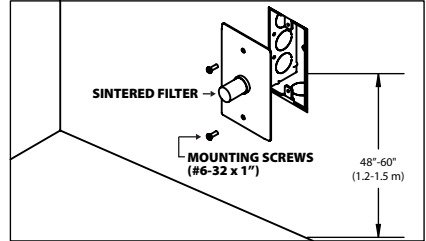
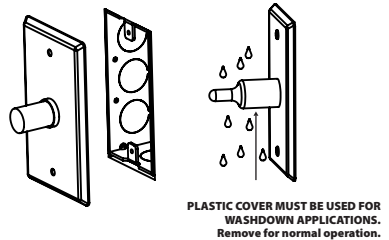

FIGURE 3: SINTERED FILTER COVER



WIRING INSTRUCTIONS

PRECAUTIONS

- Do not run the temperature sensor wiring in any conduit with line voltage (24/120/230 VAC) if utilizing resistance temperature signal.
- Remove power before wiring. Never connect or disconnect wiring with power applied.
- When using a shielded cable, ground the shield only at the controller end. Grounding both ends can cause a ground loop.
- It is recommended you use an isolated UL-listed class 2 transformer when powering the unit with 24 VAC. Failure to wire the devices with the correct polarity when sharing transformers may result in damage to any device powered by the shared transformer.
- If the 24 VDC or 24VAC power is shared with devices that have coils such as relays, solenoids, or other inductors, each coil must have an MOV, DC/AC Transorb, Transient Voltage Suppressor (ACI Part: 142583), or diode placed across the coil or inductor. The cathode, or banded side of the DC Transorb or diode, connects to the positive side of the power supply. Without these snubbers, coils produce very large voltage spikes when de-energizing that can cause malfunction or destruction of electronic circuits.

RELATIVE HUMIDITY WIRING INSTRUCTIONS

ACI recommends 16 to 26 AWG twisted pair wires or shielded cable for all transmitters. Refer to **FIGURE 4** (top) or wiring diagrams.

TEMPERATURE WIRING INSTRUCTIONS

ACI recommends 16 to 26 AWG twisted pair wires or shielded cable for all temperature sensors. ACI recommends a separate cable be pulled for Temperature signal only. Temperature Signal wiring must be run separate from low and high voltage wires (24/120/230VAC).

All ACI thermistors and RTD temperature sensors are both non-polarity and non-position sensitive. All thermistor type units are supplied with (2) flying lead wires, and all RTD's are supplied with (2) or (3) flying lead wires – see **FIGURE 6** (bottom). The number of wires needed depends on the application.

FIGURE 4: OUTPUT SIGNALS

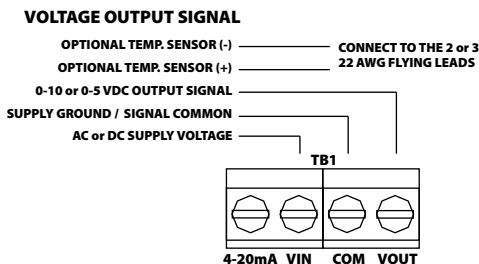

FIGURE 5: PRINTED CIRCUIT BOARD

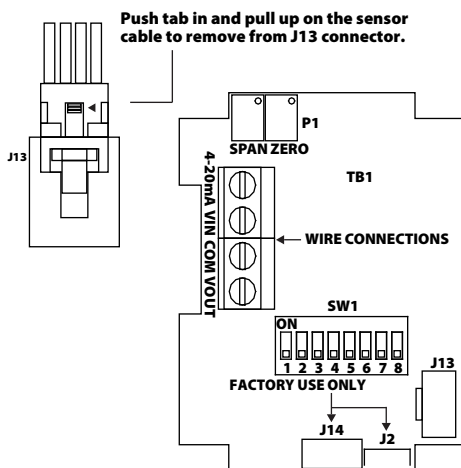
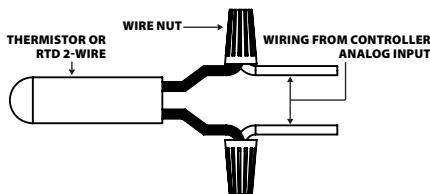
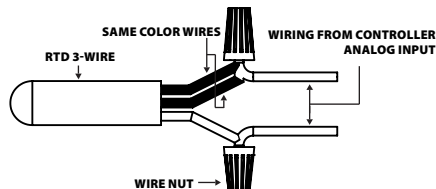

FIGURE 6: WIRING

2-WIRE THERMISTOR or RTD WIRING



3-WIRE RTD WIRING



WIRING INSTRUCTIONS (Continued)

Connect thermistor/RTD wire leads to controller analog input wires using wire nuts, terminal blocks, or crimp style connectors. All wiring must comply with local and National Electric Codes.

Note: When using a shielded cable, be sure to connect only (1) end of the shield to ground at the controller. Connecting both ends of the shield to ground may cause a ground loop. When removing the shield from the sensor end, make sure to properly trim the shield to prevent any chance of shorting.

Note: If the controller requires a (2) wire input for a RTD, connect the (2) common wires (same color) together. If the controller requires (3) wires, use (3) individual wires - see **FIGURE 6** (p. 2).

OUTPUT SIGNALS

Switches 6, 7, and 8 are used to set the RH output signal. Refer to **FIGURE 7** (below) for switch settings.

FIGURE 7: OUTPUT SELECTION SWITCHES



HUMIDITY REVERSE ACTING OUTPUT

The output is direct acting and can be changed to reverse acting mode. The output range stays the same but the corresponding RH value is opposite.

Examples:

Direct Acting (DA)

0-10 V output mode,
0 V = 0% RH and 10 V = 100% RH

Reverse Acting (RA)

0-10 V output mode,
0 V = 100% and 10 V = 0%

To change the transmitter to reverse acting or back to direct acting, set switch 4 to ON to put the unit in setup mode. After switch 4 is on, turning switch 2 to ON will put the unit in direct/reverse acting mode. When switch 2 is set to ON, the output can be used to show if the unit is in direct or reverse acting mode. For direct acting, the output will be 1 V for 0-5 V or 2 V for 0-10 V. For reverse acting the output will be 4 V for 0-5 V or 8 V for 0-10 V.

With switches 2 and 4 ON, each time switch 5 is set to ON the output will change to reverse acting or direct acting. To reset the unit to the default setting, toggle both switches 5 and 6 ON then OFF while both switches 2 and 4 are ON. When all calibration is completed, remember to place the switches back into the positions that correspond to the output needed as shown in **FIGURE 7** (above).

RH CALIBRATION INSTRUCTIONS

Note: This is only a single point calibration. All transmitters are factory calibrated to meet/exceed published specifications. Field adjustment should not be necessary.

The dipswitch allows the user to calibrate the sensor through the software. Setting switch 4 ON will put the transmitter into setup mode allowing the increment and decrement to work.

Once in setup mode, the output will change to 50% (2.5 V for 0-5 V or 5 V for 0-10 V). Each increment or decrement step will cause the output to change by 0.1 V for 0-5 V or 0.2 V for 0-10 V in setup mode. This can be used to show the user how far offset the transmitter is. To see the starting point again set switch 1 ON. This will show the 50% output again. When the unit is out of setup mode the output will go back to RH output. The maximum offset is 10%. There can be a total of 20 increments.

Increment RH Output

This will shift the RH output linearly up in 0.5% steps. Switch 4 must be set to ON first. After switch 4 is on, each time switch 5 is set ON the RH output will increase by 0.5%. The increase goes into effect each time switch 5 is set to ON.

Decrement RH Output

This will shift the RH output linearly down in 0.5% steps. Switch 4 must be set to ON first. After switch 4 is on, each time switch 6 is set ON the RH output will decrease by 0.5%. The decrease goes into effect each time switch 6 is set to ON.

Reset RH Output

This will reset the RH output back to the original calibration. Switch 4 must be set to ON first. After switch 4 is on, toggle switches 5 and 6 ON then OFF. After 5 and 6 are OFF slide switch 4 OFF.

When all calibration is completed, remember to place the switches back into the positions that correspond to the output needed as shown in **FIGURE 7** (p. 3).

TEST INSTRUCTIONS

Test mode will make the transmitter output a fixed 0%, 50%, or 100% value. The sensor will not affect the transmitter output. This is used for troubleshooting or testing only.

Switches 1, 2, and 3 are used for test mode. The output will be a fixed 0%, 50%, or 100% signal that corresponds to the output selected with switches 6, 7, and 8. Refer to **FIGURE 8** (right) for switch settings.

FIGURE 8: TEST SELECTION SWITCHES

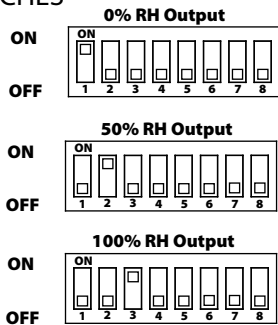

RH CONVERSION FORMULAS

	0-5 VDC	0-10 VDC
Formula:	[VDC signal] / 0.05 = percent RH	[VDC signal] / 0.10 = percent RH
Example:	1.25 vdc output signal 1.25 / 0.05 = 25% RH	7.50 vdc output signal 7.50 / 0.10 = 75% RH



PRODUCT SPECIFICATIONS

SENSOR SPECIFIC			
RELATIVE HUMIDITY SPECIFICATIONS	RH Supply Voltage:	0-5 VDC: 12 - 40 VDC / 18 - 28 VAC	
	(Reverse Polarity Protected)	0-10 VDC: 18 - 40 VDC / 18 - 28 VAC	
	RH Supply Current (VA):	8 mA VA Maximum	
	RH Output Load Resistance:	4K Ω Minimum	
	RH Output Signal:	3-wire: 0-5 or 0-10 VDC (Field Selectable)	
	RH Accuracy @ 77°F (25°C):	+/- 2%, 3%, or 5% from 10 to 95%	
	RH Measurement Range:	0-100%	
	Operating RH Range:	0 to 95% RH, non-condensing (Conformally Coated PCB's)	
	Operating Temperature Range:	-40 to 140 °F (-40 to 60 °C)	
	Storage Temperature Range:	-40 to 149 °F (-40 to 65 °C)	
	RH Stability Repeatability Sensitivity:	Less than 2% drift / 5 years 0.5% RH 0.1% RH	
	RH Response Time (T63):	20 Seconds Typical	
	RH Sensor Type:	Capacitive with Hydrophobic Filter	
	RH Transmitter Stabilization Time:	30 Minutes (Recommended time before doing accuracy verification)	
RH Connections Wire Size:	Screw Terminal Blocks (Polarity Sensitive) 16 (1.31 mm ²) to 26 AWG (0.129 mm ²)		
RH Terminal Block Torque Rating:	4.43 to 5.31 lb-in (0.5 to 0.6 Nm)		
Wall Plate Material:	430 Stainless Steel (Brushed Stainless Steel Finish)		
Foam Material Foam Thickness:	Cross-linked LPDE (White) 0.25" (6.35 mm)		
Foam Flammability Rating:	FMVSS-302		
Sintered Filter Material:	304 Series Stainless Steel		
SENSOR NON-SPECIFIC			
TEMPERATURE SENSOR SPECIFICATIONS (OPTIONAL)	Lead Wire Length	14" (35.6 cm) 22 AWG (0.65 mm)	
	Insulation Rating	Etched Teflon (PTFE) Colored Leads Mil Spec 1678/4 Type E	
	THERMISTOR		
	Sensor Output @ 25 °C (77 °F): (Lead Wire Colors)	A/1.8K: 1.8 K Ω nominal (Red/Yellow) A/3K: 3 K Ω nominal (White/Brown) A/AN (Type III): 10 K Ω nominal (White/White) A/AN-BC: 5.238 K Ω nominal (White/Yellow) A/CP (Type II): 10 K Ω nominal (White/Green) A/50K: 50K Ω nominal (Brown/Yellow)	A/CSI: 10 K Ω nominal (Green/Yellow) A/10KS: 10 K Ω nominal (White/Blue) A/10K-E1: 10 K Ω nominal (Gray/Orange) A/20K: 20 K Ω nominal (Brown/Blue) A/100KS: 100 K Ω nominal (Black/Yellow)
	Accuracy @ 0-70 °C (32 - 158 °F):	A/1.8K Series: +/- 0.5 °C @ 25 °C (77 °F) and (+/-1.0 °C) (+/-1.8 °F)	A/10K-E1 Series: +/- 0.3 °C (+/- 0.54 °F) All Else: +/- 0.2 °C (+/- 0.36 °F)
	PLATINUM		
	Sensor Output @ 0 °C (32 °F):	A/100: 100 Ω nominal	A/1K: 1 K Ω nominal
	Accuracy:	+/- 0.06% Class A (Tolerance Formula: +/- °C = (0.15 °C + (0.002 * t)) where t is the absolute value of Temperature above or below 0 °C in °C)	
		@ -40 °C (-40 °F): +/- 0.23°C (+/- 0.414°F)	@ 60 °C (140 °F): +/- 0.27 °C (+/- 0.49 °F)
		@ 0 °C (32 °F): +/- 0.15 °C (+/- 0.27 °F)	
	NICKEL		
	Sensor Output @ 21.1 °C (70 °F):	1 K Ω nominal (Red/Red)	
	Accuracy:	@ -40 °C (-40 °F): +/- 1.52 °C (+/- 2.73 °F)	@ 21.1 °C (70 °F): +/- 0.17 °C (+/- 0.34 °F)
		@ 0 °C (32 °F): +/- 0.4 °C (+/- 0.72 °F)	@ 54.4 °C (130 °F): +/- 0.56 °C (+/- 1.00°F)
BALCO			
Sensor Output @ 21.1 °C (70 °F):	1 K Ω nominal (Orange/Yellow)		
Accuracy:	@ 21.1 °C (70 °F): +/- 1%		

W.E.E.E. DIRECTIVE

At the end of their useful life the packaging and product should be disposed of via a suitable recycling centre. Do not dispose of with household waste. Do not burn.



TROUBLESHOOTING

HUMIDITY READING PROBLEM	SOLUTION(S)
No Reading	<ul style="list-style-type: none"> • Check that you have the correct supply voltage at the power terminal blocks. • Check that wiring configurations and all DIP switch settings are as in FIGURE 4 and 7. • Verify that the terminal screws are all connected tightly and that all of the wires are firmly in place.
Erratic readings	<ul style="list-style-type: none"> • Verify that all of the wires are terminated properly. • Make sure that there is no condensation on the board. • Check that the input power is clean. In areas of high RF interference or noise, shielded cable may be necessary to stabilize signal.
Inaccurate readings	<ul style="list-style-type: none"> • Verify proper mounting location to confirm no external factors (see mounting locations above). • Check the output (voltage or current) against a highly accurate recently calibrated secondary reference. Measure RH at the location of the sensor using the secondary reference, then calculate the RH percentage using the RH CONVERSION FORMULAS (p. 4). Compare the calculated output to reference. • If the sensor is brand new, leave the sensor powered for at least 30 minutes to stabilize. • If you suspect that the transmitter is not reading within the specified tolerance, please contact ACI for further assistance.
TEMPERATURE (Optional) PROBLEM	SOLUTION(S)
Sensor reading is incorrect	<ul style="list-style-type: none"> • Verify sensor wiring to controller is not damaged and has continuity • Verify sensor or wires are not shorted together • Verify controller is setup for correct sensor curve • Disconnect sensor wires, and take a resistance (ohm) reading with a multimeter • Compare the resistance reading to the Temperature Vs Resistance Curves online: http://www.workaci.com/content/thermistor-curves-0 • Verify proper mounting location to confirm no external factors
Sensor reads infinity/very high resistance	<ul style="list-style-type: none"> • Sensor or wires are open
Sensor reads low resistance	<ul style="list-style-type: none"> • Sensor or wires are shorted together
Erratic readings	<ul style="list-style-type: none"> • Bad wire connections

WARRANTY

The ACI Wall Plate Series RH sensors are covered by ACI's Five (5) Year Limited Warranty, which is located in the front of ACI'S SENSORS & TRANSMITTERS CATALOG or can be found on ACI's website: www.workaci.com.

