



## PRECAUTIONS

- **DO NOT RUN THE WIRING IN ANY CONDUIT WITH LINE VOLTAGE (24/120/230 VAC).**

## GENERAL INFORMATION

The Averaging sensor is a multi-point temperature sensor that is designed for use with electronic controllers in commercial heating and cooling building management systems. It is available with multiple thermistor or RTD options. The ACI Averaging Series provides a better average temperature of the air inside the duct compared to a single point duct sensor. Averaging sensors are sold in either Copper or Flexible variations. Refer to **Product Specifications** near the end of this document (p. 5).

## FIGURE 1: ENCLOSURE DIMENSIONS

### PLASTIC BOX (-PB)

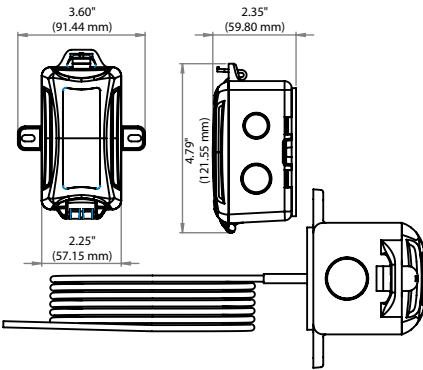

### GALVANIZED ENCLOSURE (-GD)

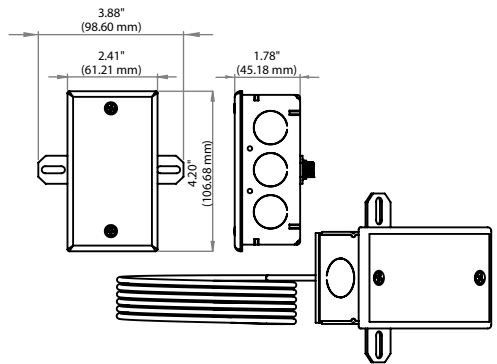

### BELL BOX (-BB)

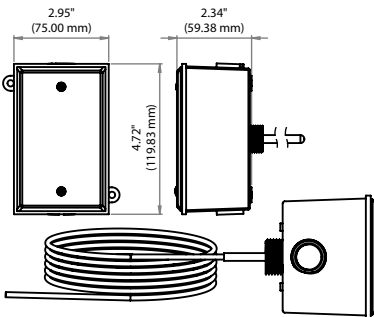

### NEMA -4X (-4X)

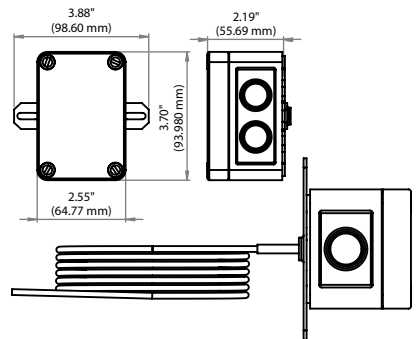

## MOUNTING INSTRUCTIONS

Drill a 3/8" (9.53 mm) hole in the duct. Gently uncoil the copper tubing and insert the averaging element through the hole until the foam pad is tight to the duct. The sensor should then be strung in a criss-cross pattern throughout the duct using the mounting clips provided - see **FIGURE 4** (p. 3).

Use a pattern that covers the greatest surface area of the duct to ensure that there is no stratification. When bending the copper tubing, be careful that you use a gradual bend and that you **DO NOT** kink the copper tubing. Bends should be a minimum of 2" (50.8 mm). Each unit includes nylon wire ties and mounts for mounting. Optional copper capillary (ACI Item #130525) or universal plastic mounting clips (ACI Item #145421) can be ordered. Plastic mounting clips will help insulate the copper sensing element from the metal duct. The capillary clips help avoid kinks when bending. When using Flexible averaging, do not cover the heatshrink that is located throughout the sensor (sensing points).

Drill pilot holes for the (2) mounting screws. Use the enclosure flange as a guide, or use the dimensions listed below to measure out. Now fasten and insert (2) screws #8 x 3/4" TEK (provided and recommended) through the mounting holes in the flange and tighten until the unit is held firmly to the duct. Make sure the foam pad is tight to the duct to eliminate any possible air leaks.

## FIGURE 2: MOUNTING DIMENSIONS

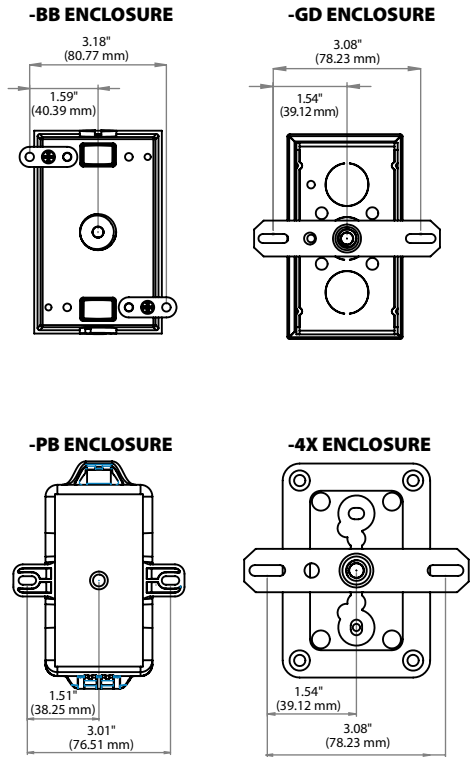

## FIGURE 3: MOUNTING CLIP DIMENSIONS

### UNIVERSAL PLASTIC MOUNTING CLIP

(ACI #145421)

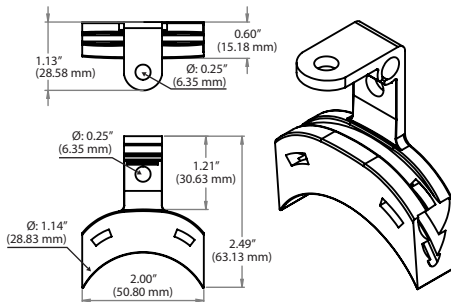

### COPPER CAPILLARY CLIP

(ACI #130525)

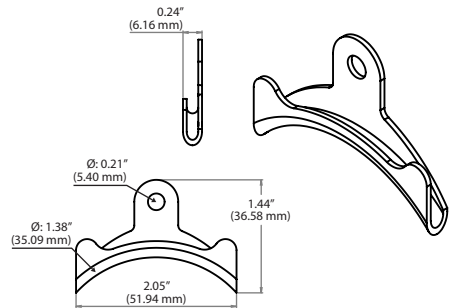

**For optimal temperature measurement, follow these tips:**

- Mount coil horizontal for vertical stratification.
- Mount coil vertical for horizontal stratification.
- The sensor must be spread evenly over the full duct.
- The entire length of the sensor coil must be installed completely inside the duct. Do not have any part of the sensor exposed to exterior air.
- When installing the sensor near air-handling units, place the sensor downstream from the fan discharge. The stratified airstream will be more uniform across the duct cross-section. If the air is not well-mixed, the reading may be inaccurate.
- If UV Lights are installed in duct, do not use Flexible Averaging. There is no UV protectant on outer cable jacket. Copper averaging must be used in this situation.

**FIGURE 4: HORIZONTAL AND VERTICAL COILING**

**HORIZONTAL COILING**

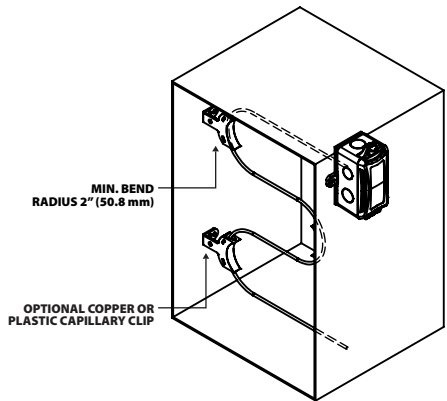
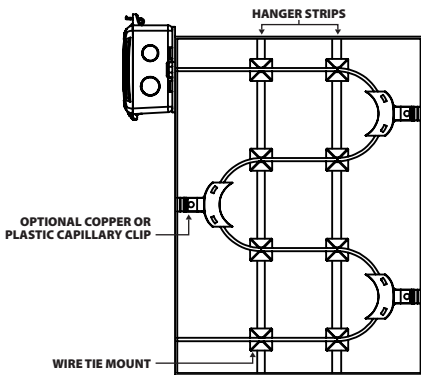

**VERTICAL COILING**

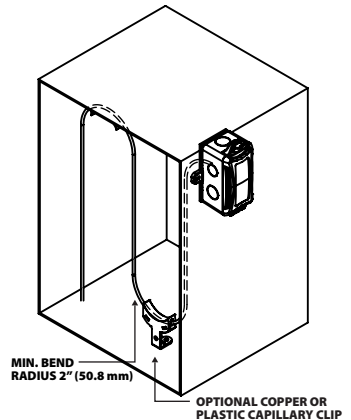
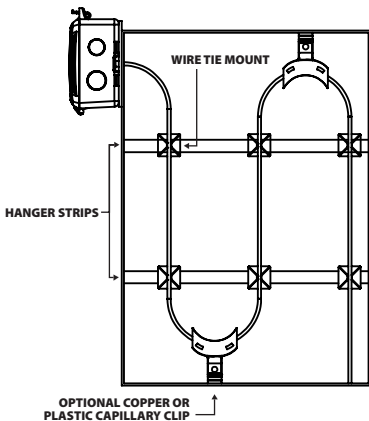

## WIRING INSTRUCTIONS

Open the cover of the enclosure. ACI recommends 16 to 26 AWG twisted pair wires or shielded cable for all sensors. Signal wiring must be run separate from low and high voltage wires (24/120/230VAC). All ACI thermistors and RTD temperature sensors are both non-polarity and non-position sensitive.

All thermistor type units are supplied with (2) flying lead wires, and all RTD's are supplied with (2) or (3) flying lead wires – see **FIGURE 5** (right). The number of wires needed depends on the application.

Connect thermistor/RTD wire leads to controller analog input wires using wire nuts, terminal blocks, or crimp style connectors. All wiring must comply with all local and National Electric Codes. After wiring, attach the cover to the enclosure.

**Note:** When using a shielded cable, be sure to connect only (1) end of the shield to ground at the controller. Connecting both ends of the shield to ground may cause a ground loop. When removing the shield from the sensor end, make sure to properly trim the shield to prevent any chance of shorting.

**Note:** If the controller requires a (2) wire input for a RTD, connect the (2) common wires (same color) together. If the controller requires (3) wires, use (3) individual wires.

## FIGURE 5: TEMPERATURE WIRING

### 2-WIRE THERMISTOR or RTD WIRING

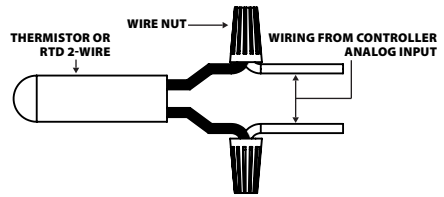

### 3-WIRE RTD WIRING

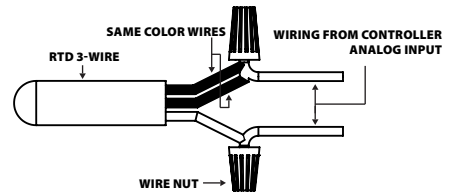

## TROUBLESHOOTING

PROBLEM	SOLUTION(S)
<b>Sensor reading is incorrect</b>	<ul style="list-style-type: none"> <li>• Verify sensor wiring to controller is not damaged and has continuity.</li> <li>• Verify sensor or wires are not shorted together.</li> <li>• Verify controller is setup for correct sensor curve.</li> <li>• Disconnect sensor wires and take a resistance (ohm) reading with a multimeter.</li> <li>• Compare the resistance reading to the Temperature Vs Resistance Curves online: <a href="http://www.workaci.com/content/thermistor-curves-0">http://www.workaci.com/content/thermistor-curves-0</a></li> <li>• Verify proper mounting location to confirm no external factors are affecting reading.</li> </ul>
<b>Sensor reads infinity/very high resistance</b>	<ul style="list-style-type: none"> <li>• Sensor or wires are open.</li> </ul>
<b>Sensor reads low resistance</b>	<ul style="list-style-type: none"> <li>• Sensor or wires are shorted together.</li> </ul>
<b>Erratic readings</b>	<ul style="list-style-type: none"> <li>• Bad wire connections.</li> </ul>

## W.E.E.E. DIRECTIVE

At the end of their useful life the packaging and product should be disposed of via a suitable recycling centre. Do not dispose of with household waste. Do not burn.

## WARRANTY

The ACI Averaging Series temperature sensors are covered by ACI's Five (5) Year Limited Warranty, which is located in the front of ACI's SENSORS & TRANSMITTERS CATALOG or can be found on ACI's website: [www.workaci.com](http://www.workaci.com).

# PRODUCT SPECIFICATIONS

SENSOR NON-SPECIFIC INFORMATION		
<b>Number Sensing Points:</b>	<b>8' and 12' Lengths:</b> Four	<b>24' and 50' Lengths:</b> Nine
<b>Storage Temperature Range:</b>	<b>Copper:</b> -40 to 80 °C (-40 to 185 °F)	<b>Flexible:</b> -20 to 75 °C (-4 to 167 °F)
<b>Operating Temperature Range:</b>	<b>Copper:</b> (see <b>Enclosure Specifications</b> )	<b>Flexible:</b> 0 to 75 °C (32 to 167 °F)
<b>Operating Humidity Range:</b>	<b>Copper:</b> 10 to 95% RH, non-condensing	<b>Flexible:</b> 10 to 90% RH, non-condensing
<b>Probe Material   Diameter:</b>	<b>Copper:</b> Copper   0.210" (5.34 mm)	<b>Flexible:</b> Low Smoke PVC   0.170" (4.32 mm)
<b>Wire Size</b>	<b>Copper:</b> 22 AWG (0.65 mm)	<b>Flexible:</b> 22 AWG (0.65 mm)
<b>Enclosure Specifications</b> (Material, Temperature, Flammability, NEMA/IP Ratings)	<b>"-GD" Enclosure:</b> Galvanized Steel, NEMA 1 (IP10)   <b>*Copper:</b> -40 to 115 °C (-40 to 239 °F), <b>"-PB" Enclosure:</b> ABS Plastic, UL94-HB, Plenum Rated   <b>*Copper:</b> -30 to 90 °C (-22 to 194 °F) <b>"-BB" Enclosure:</b> Aluminum, NEMA 3R (IP 14)   <b>*Copper:</b> -40 to 115 °C (-40 to 239 °F) <b>"-4X" Enclosure:</b> Polystyrene Plastic, UL94-V2, NEMA 4X (IP 66)   <b>*Copper:</b> -40 to 70 °C (-40 to 158 °F)	
THERMISTOR		
<b>Sensor Output @ 25 °C (77 °F):</b> (Lead Wire Colors)  *Does not include CL2P	<b>A/1.8K:</b> 1.8 KΩ nominal (Red/Yellow) <b>A/3K:</b> 3 KΩ nominal (White/Brown) <b>A/AN (Type III):</b> 10 KΩ nominal (White/White) <b>A/AN-BC:</b> 5.238 KΩ nominal (White/Yellow) <b>A/CP (Type II):</b> 10 KΩ nominal (White/Green)	<b>A/CSI:</b> 10 KΩ nominal (Green/Yellow) <b>A/10KS:</b> 10 KΩ nominal (White/Blue) <b>A/10K-E1:</b> 10 KΩ nominal (Gray/Orange) <b>A/20K:</b> 20 KΩ nominal (Brown/Blue) <b>A/100KS:</b> 100 KΩ nominal (Black/Yellow)
<b>Accuracy @ 0-70 °C (32 - 158 °F):</b>	<b>A/1.8K Series:</b> +/- 1.0 °C (+/- 1.8 °F)	<b>A/10KS Series:</b> +/- 0.60 °C (+/- 1.10 °F) <b>All Else:</b> +/- 0.20 °C (+/- 0.36 °F)
PLATINUM		
<b>Sensor Output @ 0 °C (32 °F):</b>	<b>A/100:</b> 100 Ω nominal	
<b>Copper Accuracy:</b>	<b>@ 0 °C (32 °F):</b> +/- 0.15% <b>@ 21 °C (70 °F):</b> +/- 0.25%	<b>@ 130 °C (266 °F):</b> +/- 1.00%
<b>Flexible Accuracy:</b>	<b>8' Length:</b> +/- 0.34 °C (+/- 0.62 °F) <b>12' Length:</b> +/- 0.34 °C (+/- 0.62 °F)	<b>24' Length:</b> +/- 0.80 °C (+/- 1.44 °F) <b>50' Length:</b> +/- 0.90 °C (+/- 1.62 °F)
BALCO		
<b>Sensor Output @ 21.1 °C (70 °F):</b> (Lead Wire Colors)	1 KΩ nominal (Orange/Yellow)	
<b>Accuracy:</b>	<b>8' Length:</b> +/- 1.26% @ 21.1 °C (70 °F) <b>12' Length:</b> +/- 1.37% @ 21.1 °C (70 °F)	<b>24' Length:</b> +/- 1.64% @ 21.1 °C (70 °F)
NICKEL		
<b>Sensor Output @ 21.1 °C (70 °F):</b> (Lead Wire Colors)	1 KΩ nominal (Red/Red)	
<b>Copper Accuracy:</b>	<b>8' and 12' Lengths:</b> <b>@ 21.1 °C (70 °F):</b> +/- 0.31 °C (+/- 0.56 °F) <b>@ 54.4 °C (130 °F):</b> +/- 0.71 °C (+/- 1.28 °F)	<b>24' Lengths:</b> <b>@ 21.1 °C (70 °F):</b> +/- 0.41 °C (+/- 0.74 °F) <b>@ 54.4 °C (130 °F):</b> +/- 0.87 °C (+/- 1.56 °F)
<b>Flexible Accuracy:</b>	<b>8' and 12' Lengths:</b> <b>@ 21.1 °C (70 °F):</b> +/- 0.23 °C (+/- 0.40 °F) <b>@ 54.4 °C (130 °F):</b> +/- 1.59 °C (+/- 1.06 °F)	<b>24' and 50' Lengths:</b> <b>@ 21.1 °C (70 °F):</b> +/- 0.24 °C (+/- 0.42 °F) <b>@ 54.4 °C (130 °F):</b> +/- 0.61 °C (+/- 1.09 °F)

