



PRECAUTIONS

- **DO NOT RUN THE WIRING IN ANY CONDUIT WITH LINE VOLTAGE (24/120/230 VAC).**

GENERAL INFORMATION

The outside air sensor is a single point temperature sensor that is designed for use with electronic controllers in commercial heating and cooling building management systems. It is available with multiple thermistor or RTD options.

For optimal temperature readings, follow these tips:

- Avoid mounting to chimney walls, above windows, above vents, near doors, or dampers.
- Mount at least 1'-2' (0.3-0.6 m) below eave to prevent thermal radiation from affecting performance – see **FIGURE 2** (p. 2).
- Mount at least 4' (1.22 m) above ground to prevent thermal radiation rising up affecting performance.
- Mount in shade on North side of the structure to minimize sun exposure. In the Southern hemisphere the South side of the building is where the sensor should be mounted.
- The plastic tube that houses the sensor must be pointed down to avoid debris, water, or ice potentially affecting sensor performance.

MOUNTING INSTRUCTIONS

Attach the base directly to the wall. Mounting holes are located at the corners of the housing – see **FIGURE 1** (right). Drill pilot holes for the mounting screws. Use the enclosure mounting holes as a guide, or use the dimensions listed below to measure out. Install the PG11 watertight fitting supplied with the sensor if not using conduit. The outer knockout ring (PG 11/16) on housing should not be removed when using a ½" NPT conduit fitting.

FIGURE 1: ENCLOSURE DIMENSIONS

NEMA -4X (-4X)

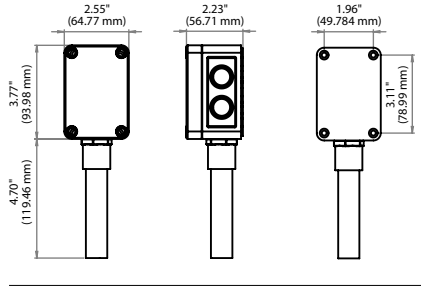

EURO (-EH)

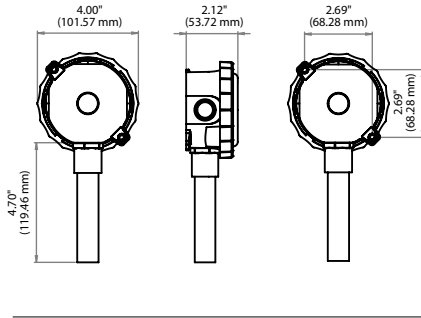

BELL BOX (-BB)

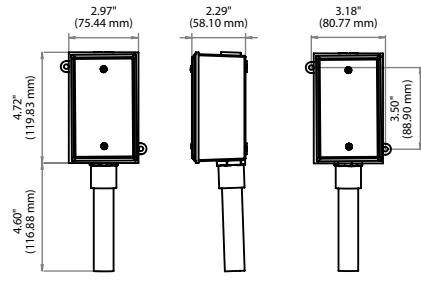

MOUNTING (Continued)

Use the enclosure mounting holes as a guide, or use the dimensions listed below to measure out. Install the PG11 watertight fitting supplied with the sensor if not using conduit. The outer knockout ring (PG 11/16) on housing should not be removed when using a 1/2" NPT conduit fitting.

Take care when mounting. Sensors should not be placed in direct sunlight, or any other potential heating or cooling sources that could affect temperature being sensed. Refer to the **Wiring Instructions** (p. 2) to make necessary connections.

WIRING INSTRUCTIONS

Open the cover of the enclosure. ACI recommends 16 to 26 AWG twisted pair wires or shielded cables for all sensors. Signal wiring must be run separate from low and high voltage wires (24/120/230VAC). All thermistor sensors are non-polarity. All thermistor type units are supplied with (2) flying lead wires – see **FIGURE 3** (right).

Connect thermistor/RTD wire leads to controller analog input wires using wire nuts, terminal blocks, or crimp style connectors. All wiring must comply with all local and National Electric Codes. After wiring, attach the cover to the enclosure. Confirm gasketed cover is fastened securely in order to prevent any moisture being introduced into housing.

Note: When using a shielded cable, be sure to connect only (1) end of the shield to ground at the controller. Connecting both ends of the shield to ground may cause a ground loop. When removing the shield from the sensor end, make sure to properly trim the shield to prevent any chance of shorting.

Note: If the controller requires a (2) wire input for a RTD, connect the (2) common wires (same color) together. If the controller requires (3) wires, use (3) individual wires.

FIGURE 2: MOUNTED ASSEMBLY

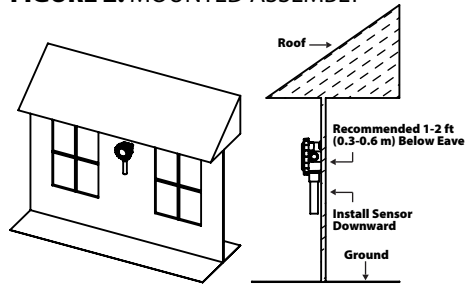
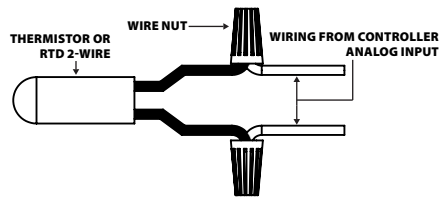
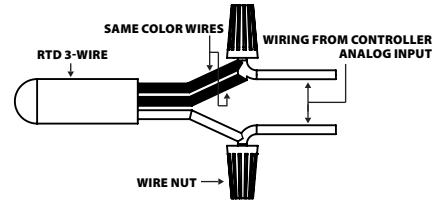

FIGURE 3: TEMPERATURE WIRING

2-WIRE THERMISTOR or RTD WIRING



3-WIRE RTD WIRING



TROUBLESHOOTING

PROBLEM	SOLUTION(S)
Sensor reading is incorrect	<ul style="list-style-type: none">• Verify sensor wiring to controller is not damaged and has continuity.• Verify sensor or wires are not shorted together.• Verify controller is setup for correct sensor curve.• Disconnect wires from sensor terminal block, tighten terminal block screws down, and take a resistance (ohm) reading with a multimeter.• Compare the resistance reading to the Temperature Vs Resistance Curves online: http://www.workaci.com/content/thermistor-curves-0• Verify proper mounting location to confirm no external factors are affecting reading.
Sensor reads infinity/very high resistance	<ul style="list-style-type: none">• Sensor or wires are open.
Sensor reads low resistance	<ul style="list-style-type: none">• Sensor or wires are shorted together.
Erratic readings	<ul style="list-style-type: none">• Condensation on PCB board• Bad wire connections.

WARRANTY

The ACI Outdoor Series temperature sensors are covered by ACI's Five (5) Year Limited Warranty, which is located in the front of ACI'S SENSORS & TRANSMITTERS CATALOG or can be found on ACI's website: www.workaci.com.

W.E.E.E. DIRECTIVE

At the end of their useful life the packaging and product should be disposed of via a suitable recycling centre. Do not dispose of with household waste. Do not burn.

PRODUCT SPECIFICATIONS

SENSOR NON-SPECIFIC INFORMATION		
Number Sensing Points:	One	
Operating Temperature Range:	-40 to 70 °C (-22 to 158 °F)	
Storage Temperature Range:	-40 to 70 °C (-40 to 158 °F)	
Operating Humidity Range:	10 to 95% RH, non-condensing	
Enclosure Specifications: (Material, Flammability, NEMA/IP Ratings)	"-EH" Enclosure: ABS Plastic with UV Protectant, UL94-V0 "-4X" Enclosure: Polystyrene Plastic, UL94-V2, IP66 (NEMA 4X) "-BB" Enclosure: Aluminum, IP32 (NEMA 3R)	
Lead Length Conductor Size:	14" (35.6 cm) / 22 AWG (0.65 mm)	
THERMISTOR		
Sensor Output @ 25 °C (77 °F): (Lead Wire Colors) *Does not include CL2P	A/1.8K: 1.8 KΩ nominal (Red/Yellow) A/3K: 3 KΩ nominal (White/Brown) A/AN (Type III): 10 KΩ nominal (White/White) A/AN-BC: 5.238 KΩ nominal (White/Yellow) A/CP (Type II): 10 KΩ nominal (White/Green)	A/CSI: 10 KΩ nominal (Green/Yellow) A/10KS: 10 KΩ nominal (White/Blue) A/10K-E1: 10 KΩ nominal (Gray/Orange) A/20K: 20 KΩ nominal (Brown/Blue) A/100KS: 100 KΩ nominal (Black/Yellow)
Accuracy @ 0-70 °C (32 - 158 °F):	A/1.8K Series: +/- 0.5 °C @ 25 °C (77 °F) and (+/-1.0 °C) (+/-1.8 °F)	A/10K-E1 Series: +/- 0.3 °C (+/- 0.54 °F) All Else: +/- 0.2 °C (+/- 0.36 °F)
PLATINUM		
Sensor Output @ 0 °C (32 °F):	A/100: 100 Ω nominal	A/1K: 1 KΩ nominal
Accuracy:	+/- 0.06% Class A (Tolerance Formula: +/- °C = (0.15 °C + (0.002 * t)) where t is the absolute value of Temperature above or below 0 °C in °C	
	@ -40 °C (-40 °F): +/- 0.23°C (+/- 0.414°F)	@ 70 °C (158 °F): +/- 0.29 °C (+/- 0.53 °F)
	@ 0 °C (32 °F): +/- 0.15 °C (+/- 0.27 °F)	
BALCO		
Sensor Output @ 21.1 °C (70 °F): (Lead Wire Colors)	1 KΩ nominal (Orange/Yellow)	
Accuracy:	@ 21.1 °C (70 °F): +/- 1%	
NICKEL		
Sensor Output @ 21.1 °C (70 °F): (Lead Wire Colors)	1 KΩ nominal (Red/Red)	
Accuracy:	@ -40 °C (-40 °F): +/- 1.52 °C (+/- 2.73 °F) @ 0 °C (32 °F): +/- 0.4 °C (+/- 0.72 °F)	@ 21.1 °C (70 °F): +/- 0.17 °C (+/- 0.34 °F) @ 54.4 °C (130 °F): +/- 0.56 °C (+/- 1.00 °F)

