



# IMMERSION SERIES

Installation & Operation Instructions

Phone: 1-888-967-5224

Website: workaci.com

## PRECAUTIONS

- **DO NOT RUN THE WIRING IN ANY CONDUIT WITH LINE VOLTAGE (24/120/230 VAC).**

## GENERAL INFORMATION

The Immersion sensor is a single point temperature sensor that is designed for use with electronic controllers in commercial heating and cooling building management systems. It is available with multiple thermistor or RTD options.

### For optimal temperature readings, follow these tips:

- Apply thermal grease to the end of the probe before installation into thermowell (ACI Item #102595).
- The tip of the thermowell should be located in the middle of the pipe.
- The sensor thermowell should be installed against the flow of the water, where water temperature is well mixed (no stratification).
- Make sure the entire thermowell is immersed. If the thermowell is longer than the pipe diameter, the thermowell should be installed in an elbow or Tee.

## THERMOWELL INSTALLATION

ACI's standard Immersion sensors are made to install into a 1/2" NPT female thread. Typically a Threadolet or Tee is installed into the pipe, but a hole can also be drilled and tapped.

## FIGURE 1: THREADOLET ASSEMBLY

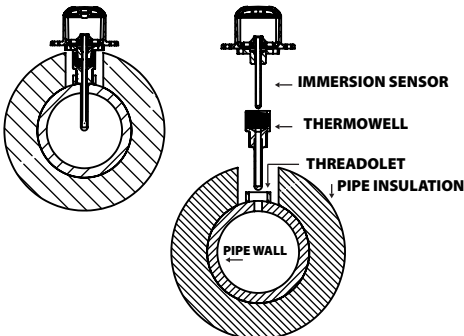

## FIGURE 1: ENCLOSURE DIMENSIONS

### PLASTIC BOX (-PB)

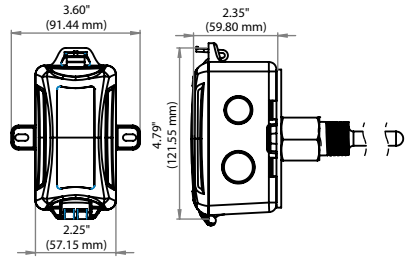

### GALVANIZED ENCLOSURE (-GD)

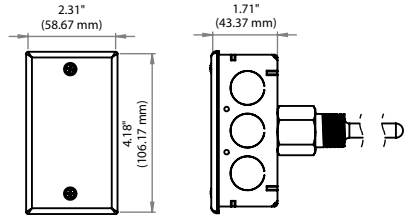

### BELL BOX (-BB)

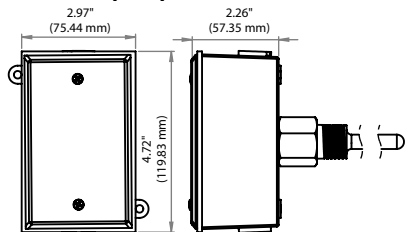

### NEMA -4X (-4X)

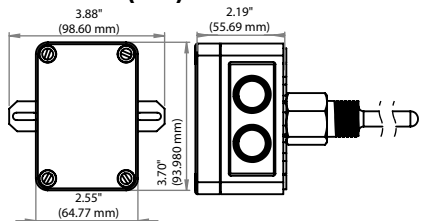

## THERMOWELL INSTALLATION

The pipe/system will need to be drained, unless a Hot Tap is being used. The recommend drill size is 23/32 in. (18 mm). Drill the hole, and tap the hole with 1/2"-14NPT.

Always use proper thread sealants on tapered pipe threads of the thermowell. Screw the thermowell into the Threadolet, Tee, or tapped hole, using a wrench to tighten it firmly. Refill the system and check for leaks.

Best practice is to apply thermal grease to the end of the probe, but not required. Insert and push the sensor probe into the thermowell. Turn the sensor probe assembly clockwise to tighten down completely. Refer to the **Wiring Instructions** (p. 2-3) to make necessary connections.

## PROBE INSERTION

The immersion sensors "-I" include a welded thermowell but can be ordered without the thermowell "-INW" version. The "-INW" includes a standard 1/2" NPS process thread to be used with a machined thermowell or previously installed thermowell. Verify the existing thermowell insertion length of the pipe is suitable for your selected Immersion.

If the length of the probe is too large, the probe may be pressed into its enclosure - up to an inch of clearance.

**Note:** \*Fabricated (welded) thermowells (-I) are not intended for moving water or high pressure service. Fluid velocity and wake frequency are primary factors in well failure. Machined thermowells (-IM) should be used in these types of applications. Fabricated thermowells are intended for tank, or low to no flow, applications.

### FIGURE 3: ELBOW ASSEMBLY

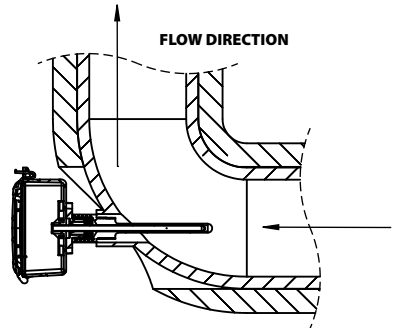

### FIGURE 4: TEE MOUNT ASSEMBLY

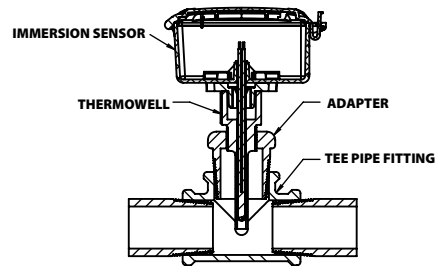

### FIGURE 5: PROBE and IMMERSION

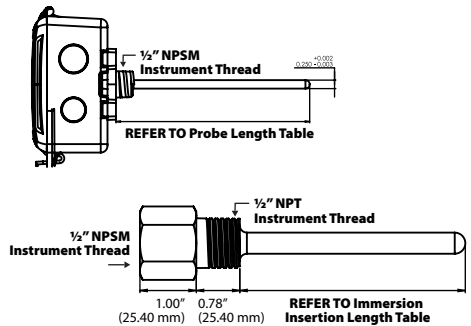

### TABLE 1: PROBE LENGTH and INSERTION LENGTH

ACI PART #	IMMERSION LENGTH	PROBE LENGTH
A/xx-l-2.5"-yy-zz	2.5" (63.50 mm)	4.31" (109.47 mm) +/- 0.13" (3.30 mm)
A/xx-l-4"-yy-zz	4.0" (101.60 mm)	5.81" (147.57 mm) +/- 0.13" (3.30 mm)
A/xx-l-6"-yy-zz	6.25" (158.75 mm)	7.81" (198.37 mm) +/- 0.13" (3.30 mm)

## WIRING INSTRUCTIONS

Open the cover of the enclosure. ACI recommends 16 to 26 AWG twisted pair wires or shielded cable for all sensors. Signal wiring must be run separate from low and high voltage wires (24/120/230VAC). All ACI thermistors and RTD temperature sensors are both non-polarity and non-position sensitive. All thermistor type units are supplied with (2) flying lead wires, and all RTD's are supplied with (2) or (3) flying lead wires – see **FIGURE 6** (below). The number of wires needed depends on the application.

Connect thermistor/RTD wire leads to controller analog input wires using wire nuts, terminal blocks, or crimp style connectors. All wiring must comply with all local and National Electric Codes. After wiring, attach the cover to the enclosure.

**Note:** When using a shielded cable, be sure to connect only (1) end of the shield to ground at the controller. Connecting both ends of the shield to ground may cause a ground loop. When removing the shield from the sensor end, make sure to properly trim the shield to prevent any chance of shorting.

**Note:** If the controller requires a (2) wire input for a RTD, connect the (2) common wires(same color) together. If the controller requires (3) wires, use (3) individual wires.

### FIGURE 7: TEMPERATURE WIRING

#### 2-WIRE THERMISTOR or RTD WIRING

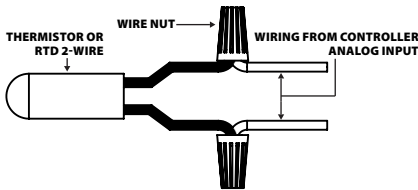

#### 3-WIRE RTD WIRING

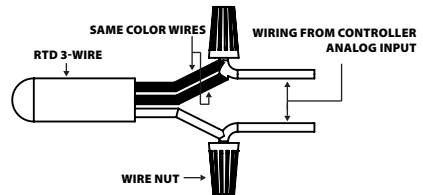

## TROUBLESHOOTING

PROBLEM	SOLUTION(S)
<b>Sensor reading is incorrect</b>	<ul style="list-style-type: none"> <li>Verify sensor wiring to controller is not damaged and has continuity.</li> <li>Verify sensor or wires are not shorted together.</li> <li>Verify controller is setup for correct sensor curve.</li> <li>Disconnect wires from sensor terminal block, tighten terminal block screws down, and take a resistance (ohm) reading with a multimeter.</li> <li>Compare the resistance reading to the Temperature Vs Resistance Curves online: <a href="http://www.workaci.com/content/thermistor-curves-0">http://www.workaci.com/content/thermistor-curves-0</a></li> <li>Verify proper mounting location to confirm no external factors are affecting reading.</li> </ul>
<b>Sensor reads infinity/very high resistance</b>	<ul style="list-style-type: none"> <li>Sensor or wires are open.</li> </ul>
<b>Sensor reads low resistance</b>	<ul style="list-style-type: none"> <li>Sensor or wires are shorted together.</li> </ul>
<b>Erratic readings</b>	<ul style="list-style-type: none"> <li>Condensation on PCB board</li> <li>Bad wire connections.</li> </ul>

## WARRANTY

The ACI Immersion Series temperature sensors are covered by ACI's Five (5) Year Limited Warranty, which is located in the front of ACI'S SENSORS & TRANSMITTERS CATALOG or can be found on ACI's website: [www.workaci.com](http://www.workaci.com).

# PRODUCT SPECIFICATIONS

SENSOR NON-SPECIFIC INFORMATION		
<b>Number Sensing Points:</b>	One	
<b>Storage Temperature Range:</b>	-40 to 85 °C (-40 to 185 °F)	
<b>Operating Humidity Range:</b>	0 to 90% RH, non-condensing	
<b>Probe Diameter   Thermowell Bore Diameter:</b>	0.250" (6.35mm)   0.260"	
<b>Probe Material   Thermowell Material:</b>	304 Stainless Steel   304 Series Stainless Steel	
<b>Wire Size</b>	22 AWG (0.65 mm)	
<b>Thermowell Instrument   Process Thread Size:</b>	½" NPS (National Pipe Straight) Female Thread   ½" NPT (National Pipe Tapered) Male Thread	
<b>Enclosure Specifications</b> (Temperature, Material, Flammability, NEMA/IP Ratings)	<b>"-GD" Enclosure:</b> Galvanized Steel, -40 to 121 °C (-40 to 250 °F), NEMA 1 (IP10) <b>"-PB" Enclosure:</b> ABS Plastic, UL94-HB, -30 to 90 °C (-22 to 194 °F), Plenum Rated <b>"-BB" Enclosure:</b> Aluminum, -40 to 121 °C (-40 to 250 °F), Plenum Rated, NEMA 3R (IP 14) <b>"-4X" Enclosure:</b> Polystyrene Plastic, UL94-V2, -40 to 70 °C (-40 to 158 °F), NEMA 4X (IP 66)	
THERMISTOR		
<b>Sensor Output @ 25 °C (77 °F):</b> (Lead Wire Colors) <small>*Does not include CL2P</small>	<b>A/1.8K:</b> 1.8 KΩ nominal (Red/Yellow) <b>A/3K:</b> 3 KΩ nominal (White/Brown) <b>A/AN (Type III):</b> 10 KΩ nominal (White/White) <b>A/AN-BC:</b> 5.238 KΩ nominal (White/Yellow) <b>A/CP (Type II):</b> 10 KΩ nominal (White/Green)	<b>A/CSI:</b> 10 KΩ nominal (Green/Yellow) <b>A/10KS:</b> 10 KΩ nominal (White/Blue) <b>A/10K-E1:</b> 10 KΩ nominal (Gray/Orange) <b>A/20K:</b> 20 KΩ nominal (Brown/Blue) <b>A/100KS:</b> 100 KΩ nominal (Black/Yellow)
<b>Accuracy @ 0-70 °C (32 - 158 °F):</b>	<b>A/1.8K Series:</b> +/- 0.5 °C @ 25 °C (77 °F) and (+/-1.0 °C) (+/-1.8 °F)	<b>A/10K-E1 Series:</b> +/- 0.3 °C (+/- 0.54 °F) <b>All Else:</b> +/- 0.2 °C (+/- 0.36 °F)
PLATINUM		
<b>Sensor Output @ 0 °C (32 °F):</b>	<b>A/100:</b> 100 Ω nominal	<b>A/1K:</b> 1 KΩ nominal
<b>Accuracy:</b>	+/- 0.06% Class A (Tolerance Formula: +/- °C = (0.15 °C + (0.002 *  t ))) where  t  is the absolute value of Temperature above or below 0 °C in °C <b>@ -40 °C (-40 °F):</b> +/- 0.23°C (+/- 0.414°F) <b>@ 200 °C (392 °F):</b> +/- 0.55 °C (+/- 1.00 °F) <b>@ 0 °C (32 °F):</b> +/- 0.15 °C (+/- 0.27 °F)	
BALCO		
<b>Sensor Output @ 21.1 °C (70 °F):</b> (Lead Wire Colors)	1 KΩ nominal (Orange/Yellow)	
<b>Accuracy:</b>	<b>@ 21.1 °C (70 °F):</b> +/- 1%	
NICKEL		
<b>Sensor Output @ 21.1 °C (70 °F):</b> (Lead Wire Colors)	1 KΩ nominal (Red/Red)	
<b>Accuracy:</b>	<b>@ -40 °C (-40 °F):</b> +/- 1.52 °C (+/- 2.73 °F) <b>@ 0 °C (32 °F):</b> +/- 0.4 °C (+/- 0.72 °F) <b>@ 21.1 °C (70 °F):</b> +/- 0.17 °C (+/- 0.34 °F)	<b>@ 54.4 °C (130 °F):</b> +/- 0.56 °C (+/- 1.00 °F) <b>@ 121 °C (250 °F):</b> +/- 1.25 °C (2.25 °F)

## W.E.E.E. DIRECTIVE

At the end of their useful life the packaging and product should be disposed of via a suitable recycling centre. Do not dispose of with household waste. Do not burn.

