

OpenAir™ GBB/GIB Non-Spring Return Rotary Electronic Damper Actuators

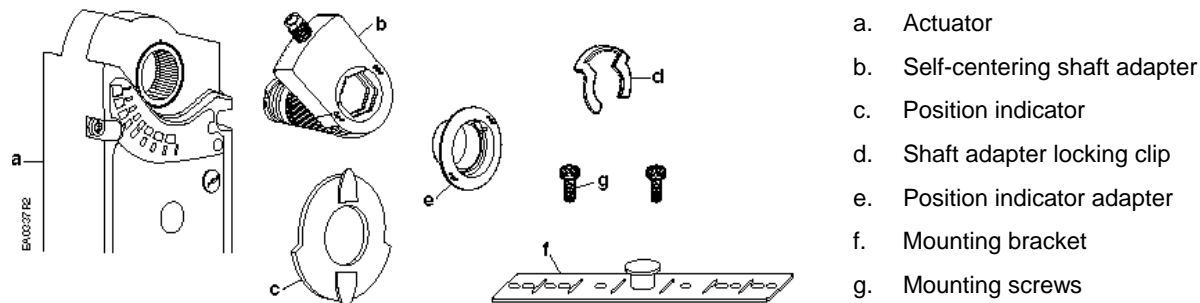

Figure 1. Parts of the GBB/GIB Rotary Actuator.

Product Description

The steps for direct-coupled mounting of the OpenAir GBB/GIB series non-spring return (NSR) three-position or modulating control rotary electronic damper actuator.

Product Numbers

GBB/GIB13x
GBB/GIB16x

Warning/Caution Notations

WARNING:		Personal injury or loss of life may occur if you do not follow the procedures as specified.
CAUTION:		Equipment damage or loss of data may occur if you do not follow procedure as specified.

Required Tools

- 10 mm (13/32-inch) open-end wrench
- Drill
 - 4 mm (5/32-inch) drill bit
- Phillips screwdriver
- Marker or pencil
- Adjustable pliers

Estimated Installation Time

30 minutes

Mounting Positions

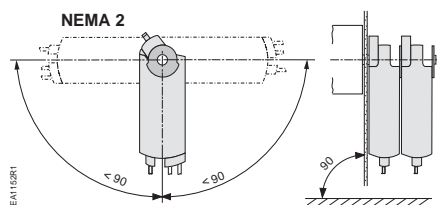

Figure 2. Acceptable NEMA 2-Positions for Single and Tandem Applications.

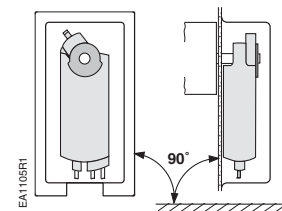

Figure 3. NEMA 3R Rating with the ASK75.1U Weather Shield in This Mounting Position Only.

The GBB/GIB actuator is UL listed to meet NEMA 3R requirements (a degree of protection against rain, sleet, and damage from external ice formation) when installed with the weather shield, product number ASK75.1U and outdoor-rated conduit fittings. The GBB/GIB must be in the vertical position.

Prerequisite

The actuator is shipped from the factory with a 5° pre-load to ensure tight close-off of the damper. To release the pre-load, press the **PUSH** button before mounting the actuator.

Installation



WARNING:
Do not open the actuator.

1. Place the actuator on the damper shaft with the front of the actuator accessible. The label and the manual override button are on the front side.
2. **For the 16x series only:** Determine the rotation of the damper shaft. Set the direction of rotation arrow to match the rotation.



Figure 4. Direction of Rotation Switch.

3. **For all models:** See Figure 5 and Figure 6 for clockwise-to-open (CW) installation. See Figure 7 and Figure 8 for counterclockwise-to-open (CCW) installation.



CAUTION:
 No more than three actuators are to be used in tandem applications.

For Tandem Applications

- The direction of rotation switches must be set identically on both actuators according to the clockwise or counterclockwise rotation of the damper shaft. The factory setting is clockwise.
- Minimum damper drive shaft length is 4-inches (100 mm).

NOTE: GIB163 and GIB164 models containing offset and span features can not be used in a tandem application.

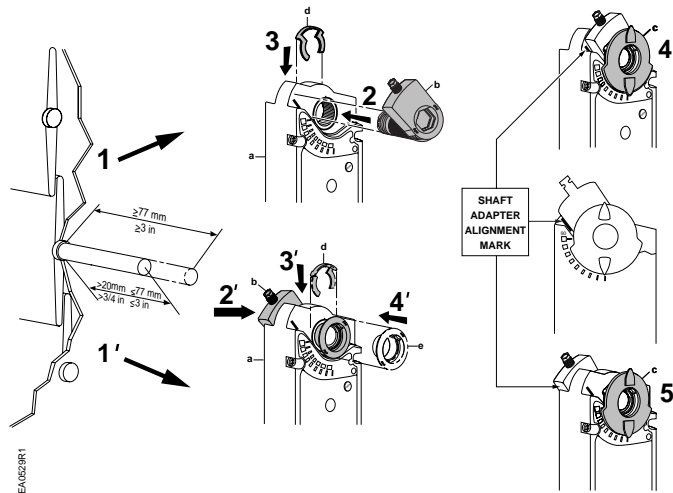

Note:
 Place the shaft adapter next to the alignment mark keeping the mark visible.

Figure 5. Shaft Adapter Placement for Clockwise Rotation on Short and Long Shafts.

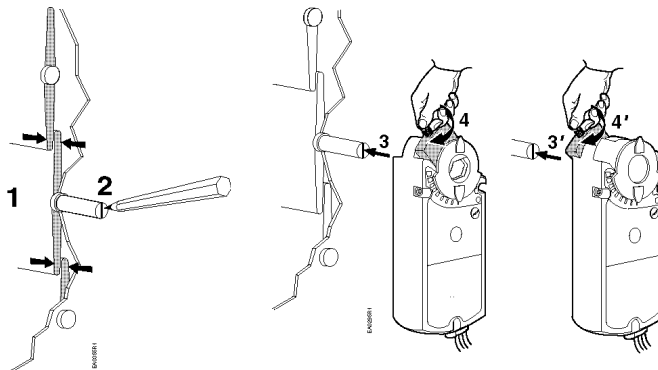

Figure 6. Mount the Actuator to the Damper Shaft. Go to Figure 9 to Complete the Mounting.

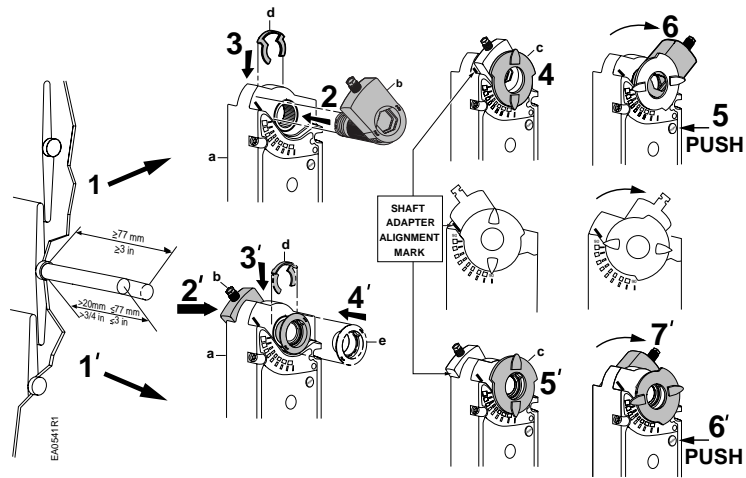

Figure 7. Shaft Adapter Placement for Counterclockwise Rotation on Short and Long Shafts.

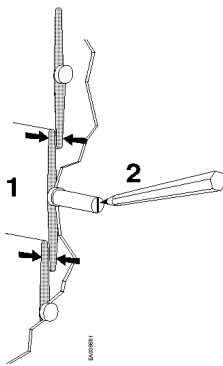

Figure 8. Mount the Actuator to the Damper Shaft.

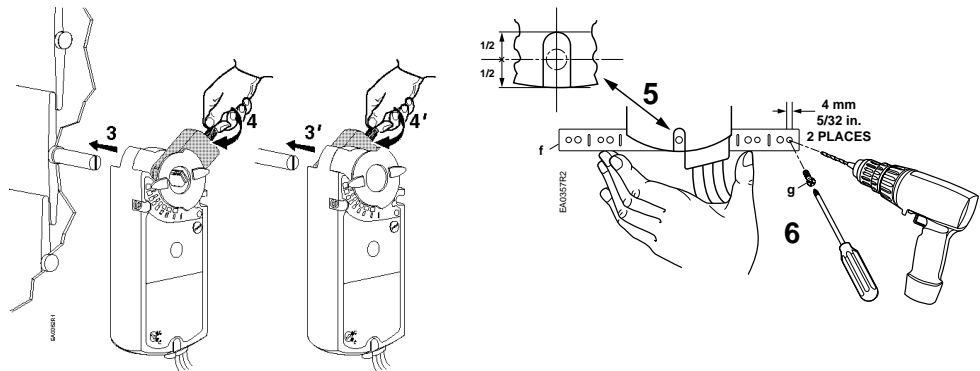

Figure 9. Attach the Mounting Bracket.

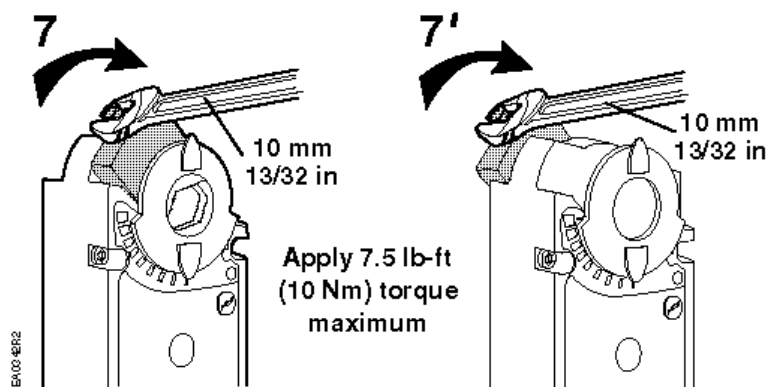

Figure 10. Fasten the Shaft Adapter to the Damper Shaft.

Manual Override

To move the damper blades without power present, do the following:

1. Hold down the **PUSH** button.
2. Make adjustments to the damper position.
3. Release the **PUSH** button.

NOTE: If there is no load, the actuator will hold the new damper position. If load conditions exist, the actuator might not be able to hold.

Once power is restored, the actuator returns to automated control.

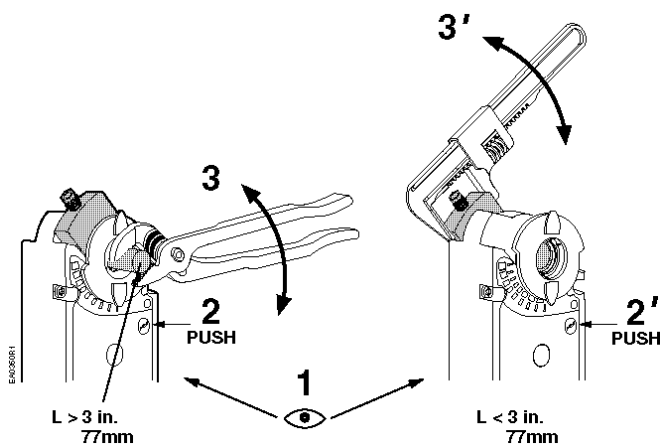

Figure 11. Manual Override for Long and Short Damper Shafts.

Mechanical Range Adjustment

The angular rotation is adjustable between 0° and 90° at 5-degree intervals.

1. Loosen the shaft adapter from the damper shaft and remove the actuator from the damper shaft.
2. Remove the clip and shaft adapter from the actuator. See Figure 12.

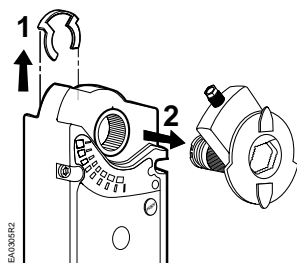

Figure 12.

3. Return the actuator gear train to the "0" position using the steps which follow for the clockwise or counterclockwise damper shaft rotation.

Clockwise-to-open:

- a. Insert the shaft adapter to the right as close as possible to the raised stop. Figure 13.

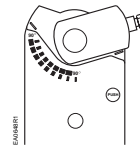

Figure 13.

- b. Hold down the **PUSH** button and rotate the shaft adapter to the left until it stops. Figure 14.

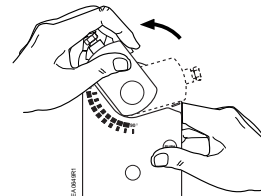

Figure 14.

- c. Release the **PUSH** button.
- d. If the shaft adapter is not resting against the left raised stop, remove the adapter and insert it against the left stop.
- e. Place the position indicator to the "0" position on the outside scale. Figure 15.

Counterclockwise-to-open:

- a. Insert the shaft adapter to the left as close as possible to the raised stop.
- b. Hold down the **PUSH** button and rotate the shaft adapter to the right until it stops.
- c. Release the **PUSH** button.
- d. If the shaft adapter is not resting against the right raised stop, remove the adapter and insert it against the right stop.
- e. Place the position indicator to "0" on the inside scale.

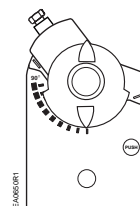

Figure 15.

4. Determine the angle of rotation for the damper blade shaft. Subtract that amount from 90°.

- Remove the shaft adapter and insert it with the position indicator pointing to mark on the scale calculated in the previous step. Figure 16.

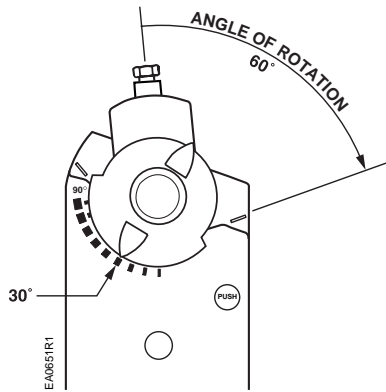

Figure 16.

- Attach the clip.
- Rotate the damper blade shaft to its "0" position.
- Return the actuator to the damper shaft and tighten the shaft adapter to the damper shaft.

Other settings

For adjustment of auxiliary switches and span/offset options, see *Technical Instructions* (GBB/GIB16x 155-176P25; GBB/GIB13x 155-177P25).

Wiring

- All wiring must conform to NEC and local codes and regulations.
- Use earth ground isolating step-down Class 2 transformers. Do not use auto transformers.
- The maximum rating for a Class 2 step-down transformer is 100 VA. Determine the supply transformer rating by summing the total VA of all actuators and components used. It is recommended that no more than 10 actuators are powered by one transformer.



CAUTION:

Do not parallel wire GBB/GIB actuators with any other type of actuator, including GBB/GIB actuators with date codes earlier than 501.



WARNING:

Mixed switch operation is not permitted to the switching outputs of both auxiliary switches (A and B).

Either AC line voltage from the same phase must be applied to all six outputs of the dual auxiliary switches, or UL-Class 2 voltage must be applied to all six outputs.

NOTE: With plenum cables, only UL-Class 2 voltage is permitted.

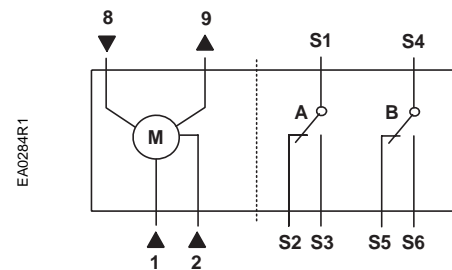

Figure 17.
 GBB/GIB16x Modulating Control, 24 Vac.

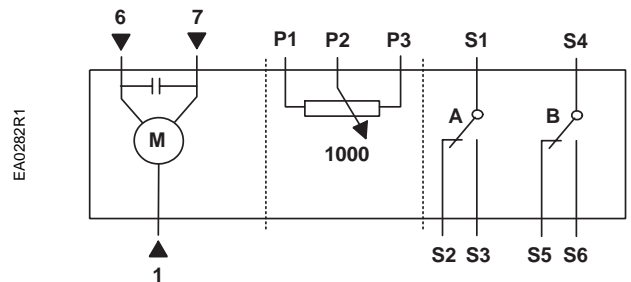

Figure 18.
 GBB/GIB13x Three-position Control, 24 Vac.

Table 1.

Standard Symbol	Function	Terminal Designations	Color
1	Supply (SP)	G	Red
2	Neutral (SN)	G0	Black
6	Control signal clockwise	Y1	Violet
7	Control signal counterclockwise	Y2	Orange
8	0 to 10 Vdc input signal	Y	Gray
9	Output for 0 to 10 Vdc position indication	U	Pink
P1	Feedback potentiometer 0 to 100% P1 – P2	a	White/red
P2	Feedback potentiometer Common	b	White/blue
P3	Feedback potentiometer 100 to 0% P3 – P2	c	White/pink
S1	Switch A Common	Q11	Gray/red
S2	Switch A N.C.	Q12	Gray/blue
S3	Switch A N.O.	Q14	Gray/pink
S4	Switch B Common	Q21	Black/red
S5	Switch B N.C.	Q22	Black/blue
S6	Switch B N.O.	Q24	Black/pink

Retrofit Wiring

Modulating Control (0 to 10 Vdc)	Siemens GBB Series GIB Series		Belimo AMB Series GMB Series		Honeywell MN7220 Series MN7220 Series		Johnson M9124 Series M9132 Series	
	Color	Number	Color	Number	Terminal Only	Number	Terminal Only	Number
Supply 24V	Red	1	Red	2		1		2
Common	Black	2	Black	1		2		1
0(2) to 10 Vdc Input	Gray	8	White	3		3		3
0(2) to 10 Vdc Feedback	Pink	9	Orange	5		5		4

Floating Control	Siemens GBB Series GIB Series		Belimo AMB Series GMB Series		Honeywell MN6120 Series MN6134 Series		Johnson M9124 Series M9132 Series	
	Color	Number	Color	Number	Terminal Only	Number	Terminal Only	Number
Common	Red	1	Black	1		2		1
24V CW	Violet	6	Red	2		3		2
24V CCW	Orange	7	White	3		4		3

Dimensions

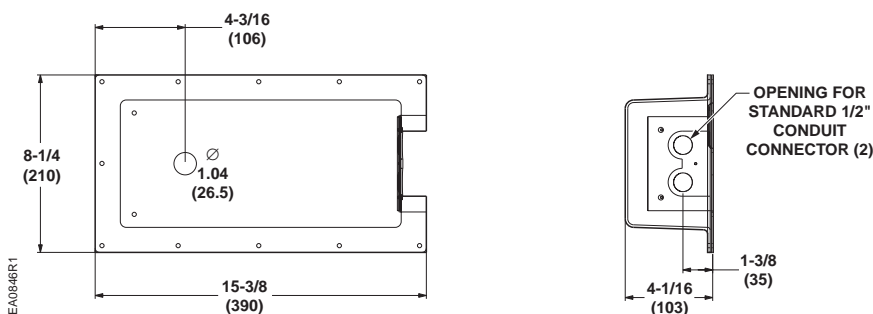

Figure 19. Dimensions of the ASK75.1U Weather Shield in Inches (Millimeters).

Dimensions, Continued

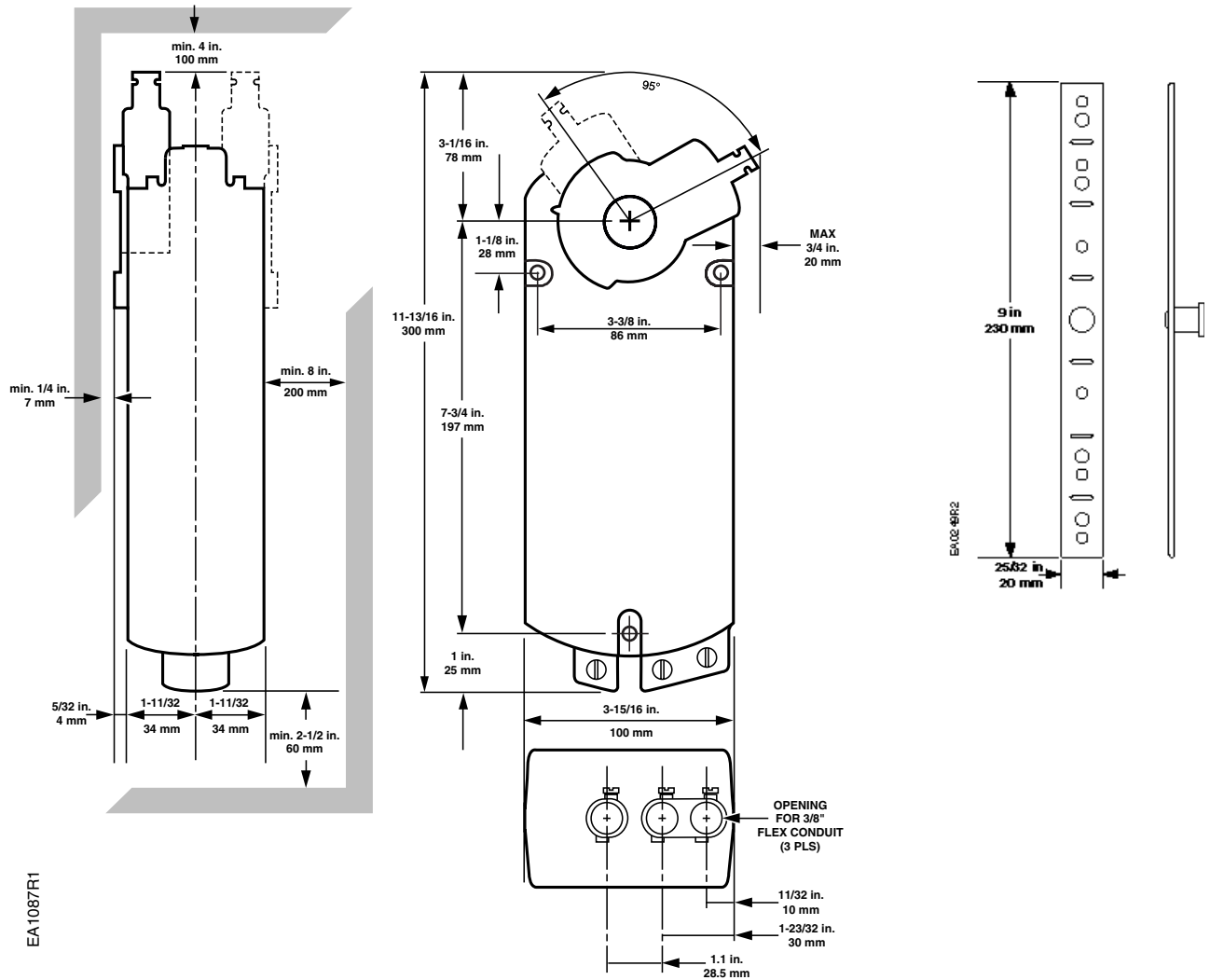

Figure 20. Dimensions of the OpenAir Actuator and Mounting Bracket in Inches (Millimeters).

Dimensions, continued

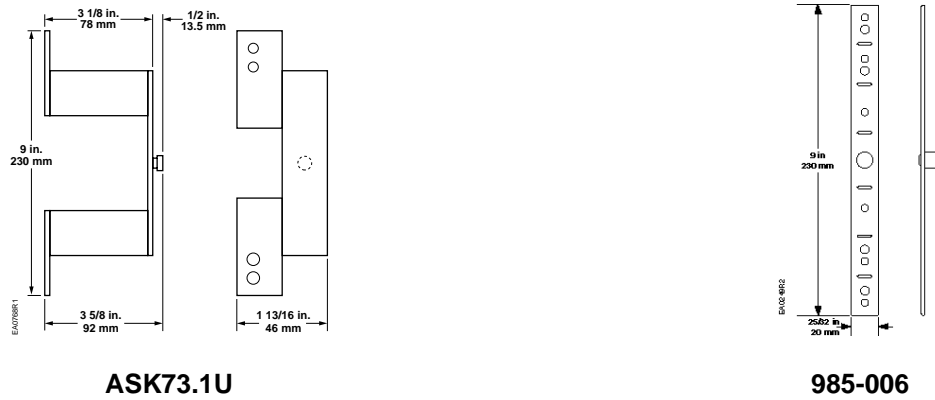

Figure 21. Dimensions of the Mounting Brackets used in Tandem Applications in Inches (mm).

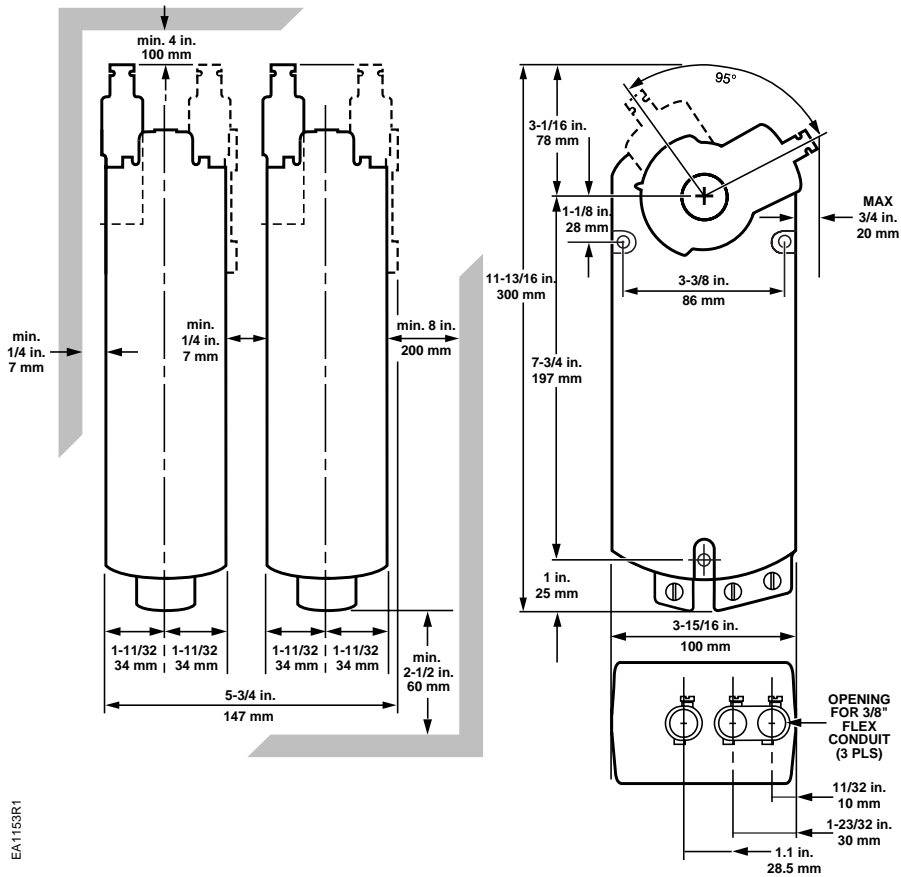

Figure 22. Dimensions and Service Envelope of the GIB Actuators in Tandem Application in Inches (mm).

Information in this publication is based on current specifications. The company reserves the right to make changes in specifications and models as design improvements are introduced. OpenAir is a trademark of Siemens Schweiz, AG. Product or company names mentioned herein may be the trademarks of their respective owners. © 2013 Siemens Industry, Inc.