

Engineering REPORT

Published by Kele & Associates

June 1994 #10

MICROPROCESSOR CONTROL FOR LARGE CHILLED WATER DISTRIBUTION SYSTEMS

*How to design real-time control for chilled water systems
serving multiple loads and supplied by several separate chilled water sources*

From *Heating/Piping/Air Conditioning*, October 1987. Reprinted with permission.

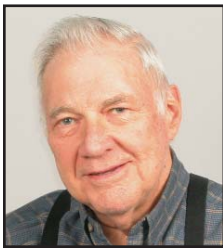

by Gil Avery

Central Chilled Water Systems are generally designed using a primary system pump, secondary zone pumps and in some instances, tertiary building pumps. These systems may operate satisfactorily. However, two exceptions limit their optimum performance:

- **Pumping costs are high because normally more water is circulated in the primary loop than is required for the load.**
- **Chiller-Load optimization is difficult to implement due to limitations of the chiller and/or system piping.**

Optimization problems due to these limitations are often encountered in hospitals, educational complexes and other campus-type facilities that may have randomly located chilled water loads (air handlers, fan coils, etc.) and sources (chillers, chilled water storage systems, etc.) due to expansion of the facility over time.

Fig. 1 TYPICAL MULTIPLE SOURCE AND LOAD CENTRAL CHILLED WATER PIPING SYSTEM

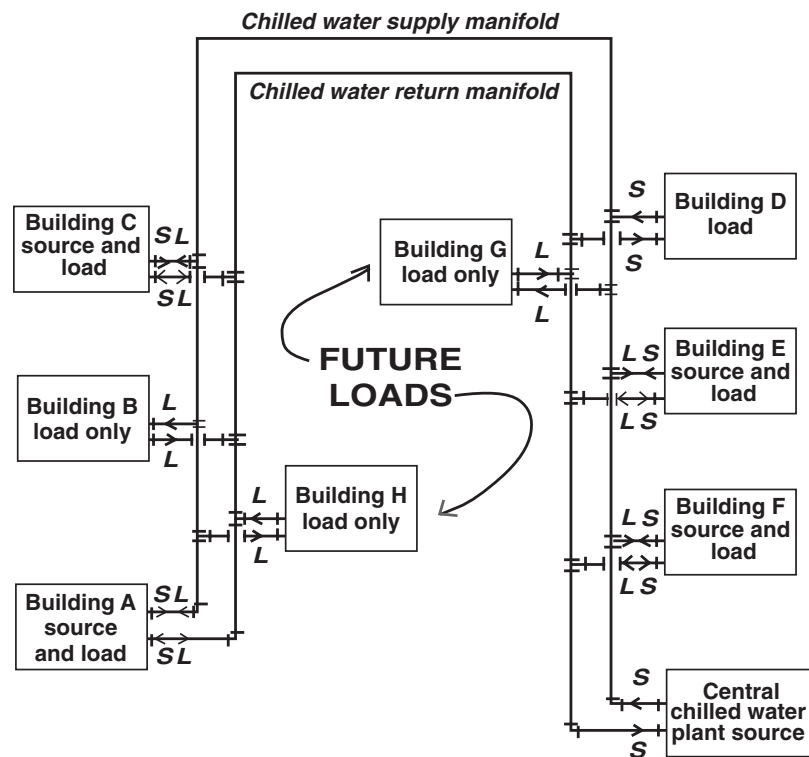

L = Flow direction when building is loading system.
S = Flow direction when building is sourcing system.

Fig. 2 MUSAL SYSTEM CENTRAL CONTROL LAYOUT

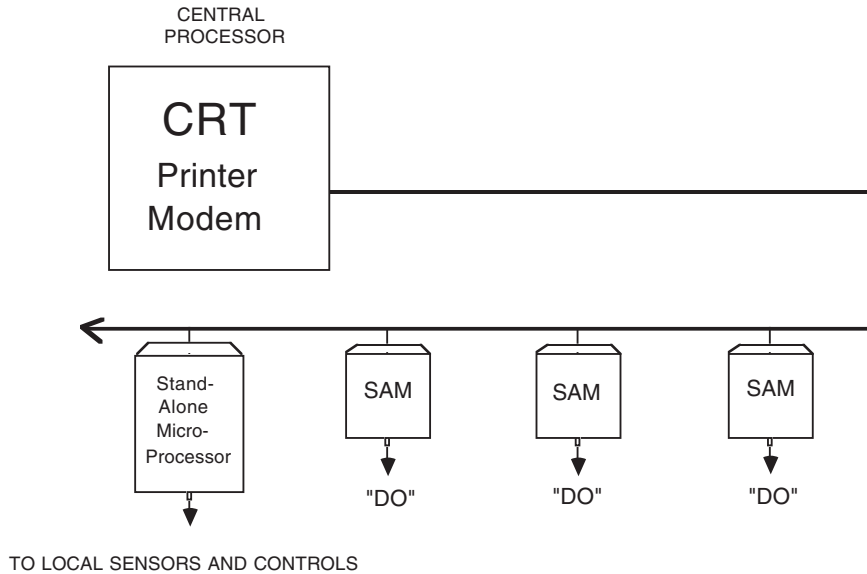

In many cases these sources can all be manifolded together as shown in Fig. 1 using a Multiple Source and Load (MUSAL) system of piping. Stand alone microprocessors (SAM's) are then used to provide optimum source/load optimization. (see Fig. 2) This technique reduces pumping costs and the size of the piping system. In addition, future loads and sources can also be connected to the manifold at any point, assuming that it has been sized to accommodate the additional flow.

Connecting the loads and sources to the manifold as shown in Figs. 3, 4 and 5 will optimize the operation of the system by selecting only the most efficient combination of chillers that can handle the loads.

CONTROL SEQUENCE

The sequence of operation for a typical load might be as follows (see Fig. 3):

1. *The SAM receives a digital signal from the building operations center to open the load valve and start the load pump.*

2. *The actual cooling load is measured by the temperature and flow sensors connected to the SAM.*

3. *The SAM relays the calculated cooling load to the CP where it is used to determine the optimum combination of sources required.*

The CP now communicates to the SAM's controlling the desired sources (see Fig. 4):

1. *The SAM receives a digital signal from the CP requesting it to go "on-line."*
2. *The SAM opens the source valve and energizes the chiller controls.*
3. *The performance of the chiller is then reported back to the CP by the SAM based on the return water temperature sensors, the flow sensor and the chiller monitoring relay, or current transducer.*
4. *The sources and loads in Fig. 5 are each controlled as above.*

The Load-Source optimization program at the CP manages the system using the following procedure of evaluation:

- A. *All loads are totaled.*
- B. *List of available sources is matched with total load in order to most efficiently match current source capacity with total load.*
- C. *Demand and downtime considerations are taken into account in generating the list of available sources.*
- D. *If demand or downtime considerations call for stopping a given chilled water source, that source will be removed from the list of available sources until it is again available.*
- E. *Start no source that has been recently stopped.*
- F. *Stop no source that has been recently started.*

Fig. 3 SCHEMATIC CONTROL AND PIPING DIAGRAM FOR *LOAD* ONLY SYSTEM

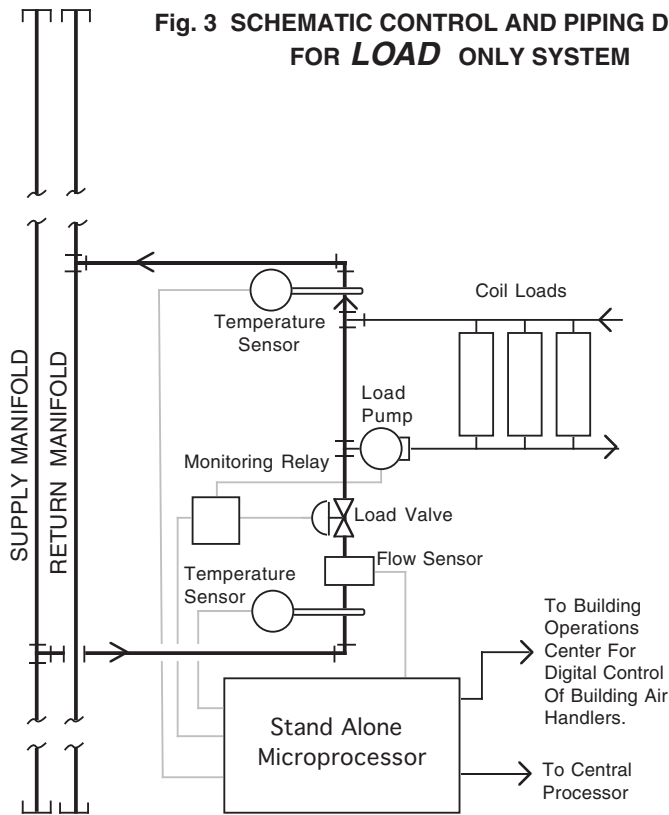
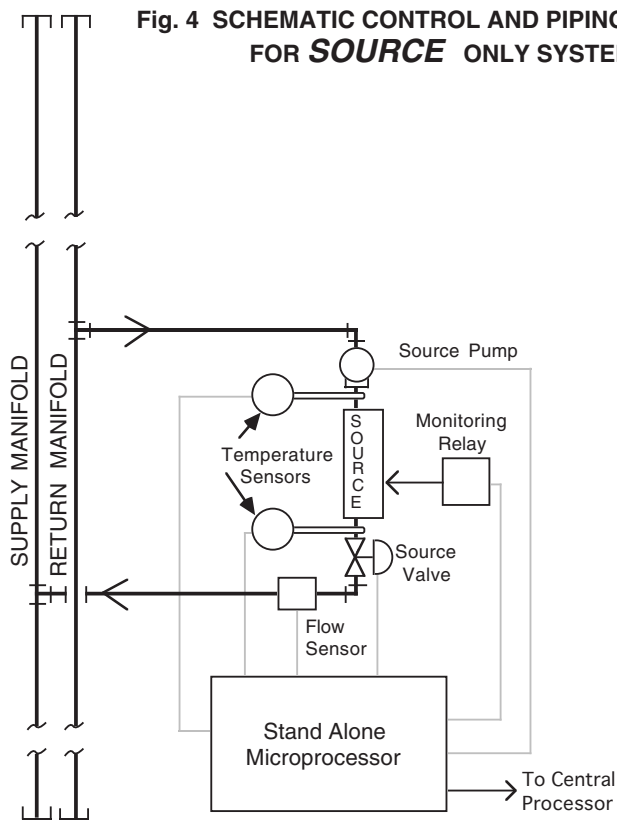

Fig. 4 SCHEMATIC CONTROL AND PIPING DIAGRAM FOR *SOURCE* ONLY SYSTEM



G. Select sources, giving consideration to expected load changes based on time of day experiences and outside conditions.

H. Communicate start-up requests to SAM's.

When the system serves multiple buildings that are individually metered, the Load-Source program can also manage the system by:

A. Switching sources when necessary to reduce demand for that particular building.

B. Using sources in high diversity buildings such as athletic facilities or auditoriums which have equipment sized for large occupancies.

C. Giving consideration to the thermal storage available in the piping manifolds and chiller bundles. This storage capacity may be drawn upon during start up or in anticipation of peak demand periods.

INFORMATION MANAGEMENT

In addition to operating the equipment at peak efficiency, the MUSAL system can display and graph the following information, providing the facility operator with valuable information that can be used to evaluate further optimization strategies. Among these are:

- **Building load vs Time of day**
- **Total load vs Time of day**
- **Building demand vs Time of day**
- **Total demand vs Time of day**
- **Individual source total operating time**

Adding watt transducers to the chillers and feeding individual chiller efficiencies back to the CP will enable the programmer to further enhance the total system efficiency.

Fig. 5 SCHEMATIC CONTROL AND PIPING DIAGRAM FOR COMBINATION SOURCE AND LOAD SYSTEM

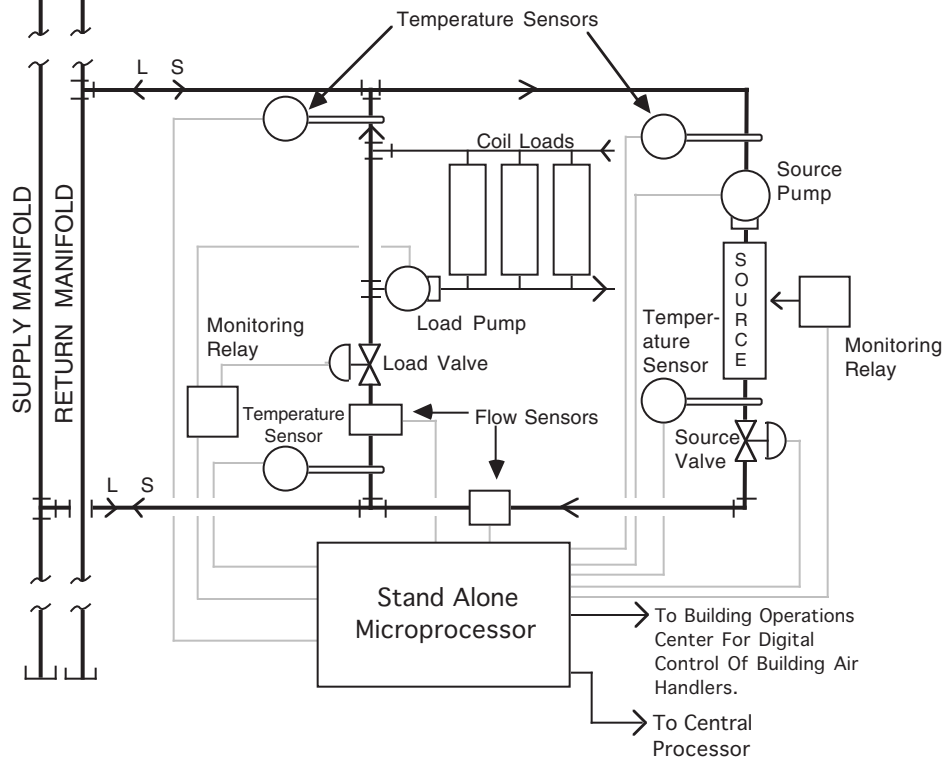

CONCLUSION

The flexibility inherent in the layout of the MUSAL system provides the engineer with the tools necessary to fine tune the CP, so that the owner can achieve peak performance from his chilled water system by utilizing the analytical speed and decision-making capabilities of today's micro-processors. Furthermore, the MUSAL system can be easily adapted to additions of loads and sources over time.