



DC(M)S-140 Series — Installation Instructions

06/30/22

Description

The OpenAir direct coupled 2-position spring return electric actuator is available in 24 Vac/dc or 120 Vac models for control of building HVAC dampers.

Features

- Brushless DC motor technology with stall protection
- Bi-directional fail-safe spring return
- Unique self-centering shaft coupling
- All metal housing
- 142 lb-in (16Nm) torque
- Manual override
- 5° preload as shipped from factory
- UL and cUL listed

Application

Used for the control of dampers requiring up to 142 lb-in (16 Nm) torque. Designed for applications that require the damper to return to its fail-safe position when there is a power failure.

Actuator Components

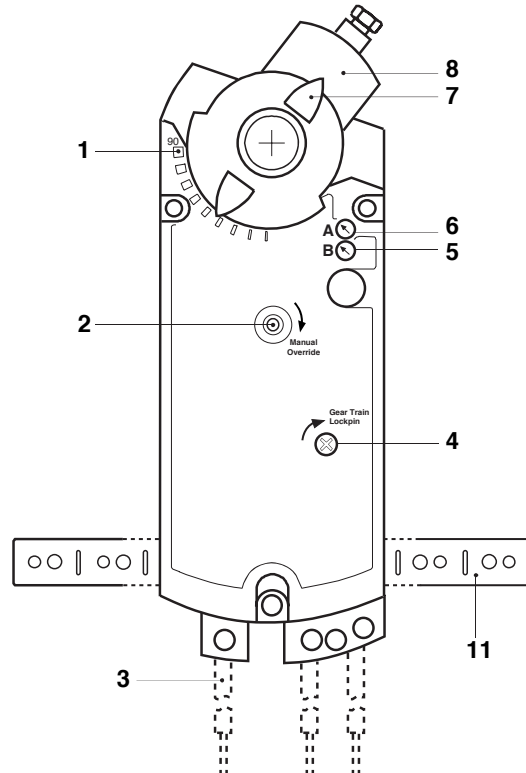
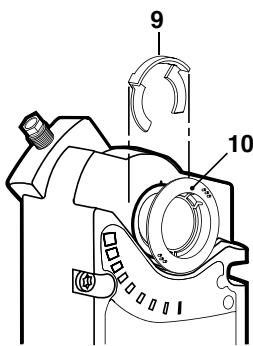

Legend

1. Positioning scale for angle of rotation
2. Manual override wrench opening and direction of rotation arrow
3. Connection cables
4. Gear train lock pin
5. Auxiliary switch B
6. Auxiliary switch A
7. Position indicator
8. Self-centering shaft adapter
9. Shaft adapter locking clip
10. Position indicator adapter
11. Mounting bracket

Figure 10. Two-position Actuator.



Operation

When power is applied, the actuator coupling moves toward the open position "90°". In the event of a power failure or when operating voltage is turned off, the actuator returns to the "0" position. In the event of a blockage in the damper, the actuator is overload protected over the full range to prevent damage to the actuator.

Life Expectancy

An improperly-tuned loop will cause excessive repositioning that will shorten the life of the actuator.

Dual Auxiliary Switch

-A Modles

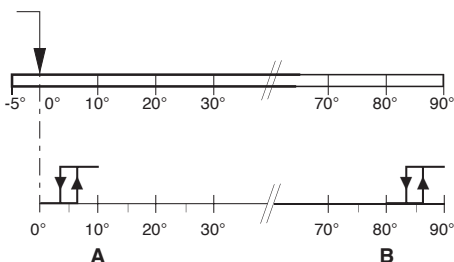

Actuator rotary range with the shaft adapter mounted at position "0".

Setting range for switches A and B
 Setting interval: 5°
 Switching hysteresis: 2°

To change the settings of A and B:

1. Make sure the actuator is in the "0" position. The scale is valid only in the "0" position.
2. Use a flat-blade screwdriver to turn the switch adjustment dials to the desired setting at which a signal is to be given.

Factory Setting

Switch A 5°
 Switch B 85°

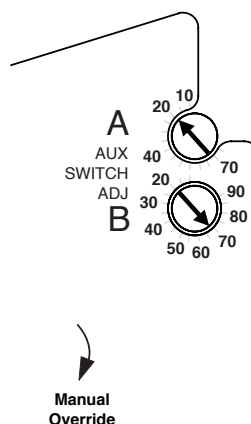

Figure 11. Dual Auxiliary Switch Dials.

Mounting and Installation

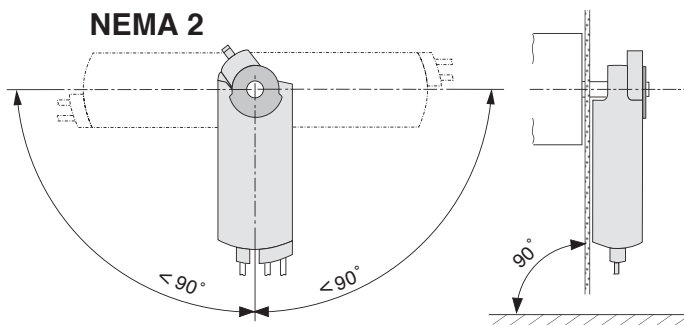

Figure 12. Acceptable NEMA 2 positions.

Flip the actuator to select either clockwise or counterclockwise fail-safe rotation of the damper shaft. Follow steps 1, 2, and 3 of Table 3 to determine the correct actuator mounting orientation.



Mounting and Installation - Con't

The shaft adapter and the position indicator can be mounted on either side of the actuator. The actuator mounting orientation and shaft length determine how they will be mounted on the actuator.

The minimum damper drive shaft length is 3/4-inches (20 mm). See Specifications for the minimum and maximum damper shaft dimensions.

The actuator is shipped from the factory with a 5° preload enabling tight close off of the damper in power-fail-close applications.

A mounting bracket is included with the actuator. The shaft adapter and mounting parts are shipped in a separate container with the actuator.

See the detailed mounting instructions included with each actuator.

Manual Override

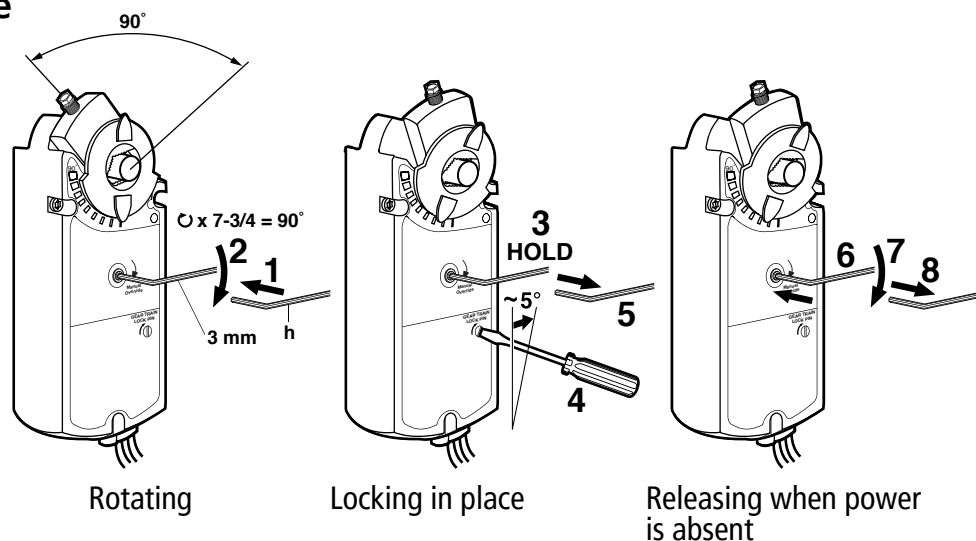

Figure 13. Manual Override.

Always turn the key in the direction of the arrow.



CAUTION:

When engaging the gear train lock pin, be careful to turn only about five degrees until you hear a click or meet slight resistance. Turning too far will strip the lock pin.

To release manual override either restore power and send a control signal, or when power is absent, insert the 3 mm hex key in the override opening, turn the key in the direction of the arrow and remove the key.



Mechanical Range Adjustment

The angular rotation is adjustable between 0 and 90° at 5 degree intervals. To limit the range of shaft movement, remove the locking clip and self-adjusting shaft adapter. Rotate the damper blade shaft to its failed position. Rotate the shaft coupling to the desired position. Insert the shaft adapter into the actuator and fasten it with the locking clip. See Figure 14.

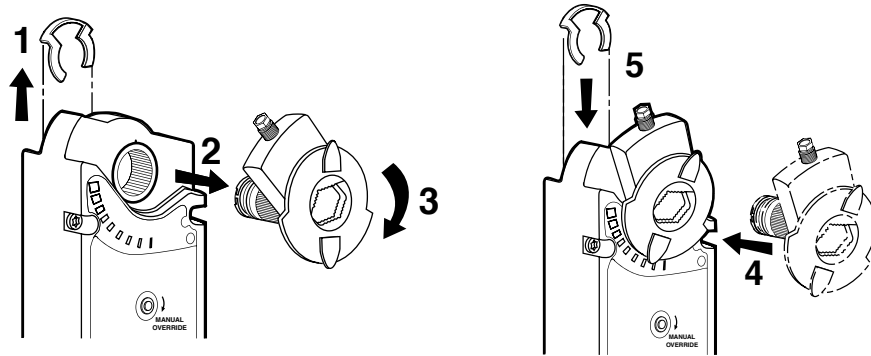
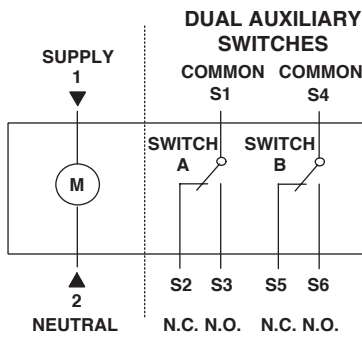

Figure 14. Mechanical Range Adjustment.

Wiring - (Cable)

On/Off with Optional AUX Switches



Pin	Cable Labeling			Meaning
	No.	Color	Abbr.	
Actuators	1	red	RD	System potential AC 24 V / DC 24...48 V
AC 24 V	2	black	BK	System neutral
DC 24...48 V	6	purple	VT	Pos. signal AC 0 V / AC 24 V / DC 24...48 V, "open"
	7	orange	OG	Pos. signal AC 0 V / AC 24 V / DC 24...48 V, "close"
	8	grey	GY	Pos. signal DC 0...10 V, 0...35 V
	9	pink	PK	Position indication DC 0...10 V
Actuators	3	brown	BN	Phase AC 120/230 V
AC 120/230 V	4	blue	BU	Neutral conductor
Auxiliary switch	S1	grey/red	GY RD	Switch A input
	S2	grey/blue	GY BU	Switch A normally-closed contact
	S3	grey/pink	GY PK	Switch A normally-open contact
	S4	black/red	BK RD	Switch B input
	S5	black/blue	BK BU	Switch B normally-closed contact
	S6	black/pink	BK PK	Switch B normally-open contact

Modulating with Optional AUX Switches

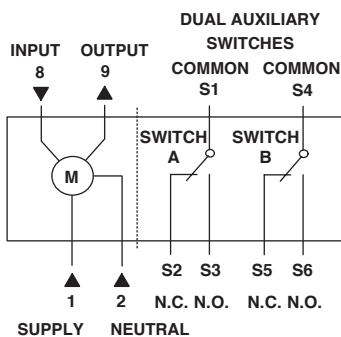

Floating with Optional AUX Switches

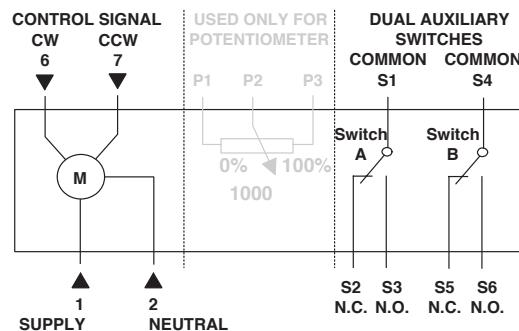

120 V On/Off with Optional AUX Switches

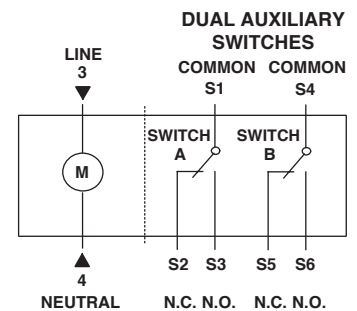



Start-Up/Commissioning 24 Vac/dc

1. Check Operation:
 - a. Connect wires 1 (red) and 2 (black) to 24 Vac/dc power supply.
 - b. Allow the actuator shaft coupling to rotate from 0 to 90.
 - c. Disconnect wire 1 (red) and the actuator shaft coupling returns to the "0" position.

2. Check Spring Return:
 - a. Connect wire 1 (red).
 - b. Allow the actuator shaft coupling to rotate halfway.
 - c. Disconnect wire 1 (red). The spring returns the actuator shaft coupling to the fail "0" position.

3. Check the Auxiliary Switch A:
 - a. Set the DMM dial to ohms (resistance) or continuity check.
 - b. Connect wires S1 and S3 to the DMM. The DMM should indicate open circuit or no resistance.
 - c. Connect wire 1 (red). The DMM should indicate contact closure as the actuator shaft coupling reaches the setting of switch A.
 - d. Connect wires S1 and S2 to the DMM. The DMM should indicate open circuit or no resistance.
 - e. Disconnect wire 1 (red). The DMM should indicate contact closure as the actuator shaft coupling reaches the setting of switch A.

4. Check the Auxiliary Switch B:
 - a. Set the DMM dial to ohms (resistance) or continuity check.
 - b. Connect wires S4 and S6 to the DMM. The DMM should indicate open circuit or no resistance.
 - c. Connect wire 1 (red). The DMM should indicate contact closure as the actuator shaft coupling reaches the setting of switch B.
 - d. Connect wires S4 and S5 to the DMM. The DMM should indicate open circuit or no resistance.
 - e. Disconnect wire 1 (red). The DMM should indicate contact closure as the actuator shaft coupling reaches the setting of switch B.

Start-Up/Commissioning 120 Vac

1. Check Operation:
 - a. Switch on 120 Vac power.
 - b. Allow the actuator shaft coupling to rotate from 0 to 90°.
 - c. Switch off 120 Vac power.
The actuator shaft coupling will return to the "0" position.

2. Check Spring Return:
 - a. Switch on 120 Vac power.
 - b. Allow the actuator shaft coupling to rotate halfway.
 - c. Switch off 120 Vac power. The spring returns the actuator shaft coupling to the fail "0" position.

3. Check the Auxiliary Switch A:
 - a. Set the DMM dial to ohms (resistance) or continuity check.
 - b. Connect wires S1 and S3 to the DMM. The DMM should indicate an open circuit or no resistance.
 - c. Switch on 120 Vac power. The DMM should indicate contact closure as the actuator shaft coupling reaches the setting of switch A.
 - d. Connect wires S1 and S2 to the DMM. The DMM should indicate open circuit or no resistance.
 - e. Switch off 120 Vac power. The DMM should indicate contact closure as the actuator shaft coupling reaches the setting of switch A.



Start-Up/Commissioning 120 Vac - Con't

4. Check the Auxiliary Switch B:
 - a. Set the DMM dial to ohms (resistance) or continuity check.
 - b. Connect wires S4 and S6 to the DMM. The DMM should indicate open circuit or no resistance.
 - c. Switch on 120 Vac power. The DMM should indicate contact closure as the actuator shaft coupling reaches the setting of switch B.
 - d. Connect wires S4 and S5 to the DMM. The DMM should indicate open circuit or no resistance.
 - e. Switch off 120 Vac power. The DMM should indicate contact closure as the actuator shaft coupling reaches the setting of switch B.

Dimensions

