

Flow sensor

Ultrasonic flow sensor provides precise fluid measurement in a heating or cooling system. Equipped with automatic temperature and glycol compensation that ensures reliable measurement. Optional thermostat heater or humidistat heater to prevent condensation. Seamless integration via BACnet, Modbus and MP-Bus. Parameters can be easily set using NFC. NIST, SI, and BIPM.



5-year warranty



Type Overview

Type	DN	DN ["]	FS [GPM]	Degree of protection NEMA/ UL
22PF-5UC	15	1/2	7.9	NEMA 2
22PF-5UD	20	3/4	13	NEMA 2
22PF-5UE	25	1	18.5	NEMA 2
22PF-5UF	32	1 1/4	31.7	NEMA 2
22PF-5UG	40	1 1/2	52.7	NEMA 2
22PF-5UH	50	2	79.2	NEMA 2
22PF-5UHH	50	2	120	NEMA 2

FS: Full scale, maximum flow

Δp: Pressure drop at FS

Technical data

Electrical Data	Nominal voltage	AC/DC 24 V
	Nominal voltage frequency	50/60 Hz
	Nominal voltage range	AC 19.2...28.8 V / DC 21.6...28.8 V
	Power consumption AC	2.2 VA
	Power consumption DC	1.1 W
	Connection supply	cable , 6 x 0.75 mm ²
Data bus communication	Communication	BACnet MS/TP Modbus RTU MP-Bus
	Number of nodes	BACnet / Modbus see interface description MP-Bus max. 8 (16)
Functional Data	Sensor technology	Ultrasonic time-of-flight (with glycol and temperature compensation)
	Application	Water Water-glycol mixture
	Configuration	via NFC, Belimo Assistant 2

Technical data

Functional Data	Voltage output	1 x 0...10 V, 0.5...10 V, 2...10 V or user defined
	Output signal active note	DC 0...10 V (factory setting), selectable via NFC max. load 1 mA User defined: - Lower limit: 0...8 V - Upper limit: 2...10 V
	Pipe connection	Internal thread NPT (female)
	Servicing	maintenance-free
	Velocity range	0.08-7.73 FPS
	Inlet Length to Meet Specified Measurement Accuracy	≥ to 0 x DN (according to EN1434-4:2022)
	Measuring Data	Measured values
Measuring fluid		chilled or hot water, up to 60% glycol max (open loop/steam not allowed)
Measuring principle		Ultrasonic volumetric flow measurement
Specification flow	Min. flow measurement	0.2% of FS
	Measuring accuracy flow	±2% of the measured value (20...100% FS) @ 68°F [20°C] / glycol 0% vol. ±0.4% of FS (0...20% FS) @ 68°F [20°C] / glycol 0% vol.
	Measuring accuracy flow note	Additional information on measuring accuracy (with diagram) can be found in the section "Measuring accuracy".
	Measurement repeatability	±0.5% (Flow)
Safety Data	Protection class IEC/EN	III, Protective Extra-Low Voltage (PELV)
	Power source UL	Class 2 Supply
	Degree of protection IEC/EN	IP54
	Degree of protection NEMA/UL	NEMA 2
	Housing	UL Enclosure Type 2
	Certification IEC/EN	IEC/EN 60730-1:11 and IEC/EN 60730-2-15:10
	Quality Standard	ISO 9001
	UL Approval	cULus acc. to UL94
	Type of action	Type 1
	Rated impulse voltage supply	0.8 kV
	Pollution degree	3
	Ambient humidity	Max. 95% RH, non-condensing
	Ambient temperature	-22...131°F [-30...55°C] -22...122°F [-30...50°C] (UL)
	Fluid temperature	-20...120°C [-4...250°F] Frost protection must be guaranteed at fluid temperatures <2 °C [<36°F]
Storage temperature	-40...176°F [-40...80°C]	
Materials	Cable	PVC
	Fluid wetted parts	Brass nickel-plated, Brass, Stainless steel, PEEK, EPDM
	Flow measuring pipe	Nickel-plated brass body

Safety Notes



This device has been designed for use in stationary heating, ventilation and air-conditioning systems and must not be used outside the specified field of application, especially in aircraft or in any other airborne means of transport.

Outdoor applications: Only possible where (sea) water, snow, ice, sunlight or aggressive gases cannot interfere directly with the device and it can be guaranteed that the ambient conditions remain at all times within the thresholds according to the data sheet.

Only authorized specialists may carry out installation. All applicable legal or institutional installation regulations must be complied with during installation.

The device contains electrical and electronic components and must not be disposed of as household refuse. All locally valid regulations and requirements must be observed.

Product Features

Operating mode

The ultrasonic flow sensor is equipped with a flow pipe, two flow transmitters and an electronic circuit. A temperature sensor is mounted in the flow pipe to compensate the temperature effects.

A sensor error occurs when the ultrasonic path is interrupted (air bubbles in the system, connection to ultrasonic transducers interrupted).

Detailed error reports are available via Belimo Assistant App or BACnet, Modbus and MP-Bus.

Collective error report display

If the output signal is set to 0.5...10 V or 2...10 V and also to flow, a collective error report is displayed with a voltage of 0.3 V. This indicates a measurement error of the temperature sensor or flow sensor.

Functions

Wires 6 and 7 are for the Modbus or BACnet communication. The physical bus address can be defined via the app.

Wire 5 can be parametrized with the app as an output signal 0...10 V (factory setting), 0.5...10 V, 2...10 V, user defined or as an MP-Bus communication. For the output signal, the flow or the fluid temperature can be selected.

The output signal can be scaled to achieve a better resolution. Factory setting is 10 V = FS (see diagram, example of output voltage characteristic curve 22PF-5UC).

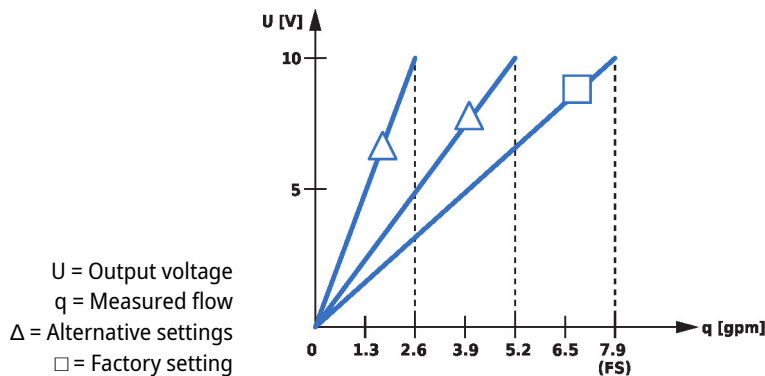

Patented glycol compensation Glycol changes the viscosity of the heat transfer fluid and as a result affects the measured volumetric flow. Without glycol compensation, volumetric flow measurements can show errors of as much as 30 percent. The patented automatic glycol compensation significantly reduces the degree of measurement error.

Selection of the fluid used:

- Water
- Propylene glycol
- Ethylene glycol
- Antifrogen L
- Antifrogen N
- DowCal 200
- DowCal 100

Determining the glycol concentration requires recurring temperature changes of min. 2 K within the flow sensor during operation. Installing the flow sensor in the temperature-variable part of the system is recommended to ensure these temperature changes.

Pressure drop

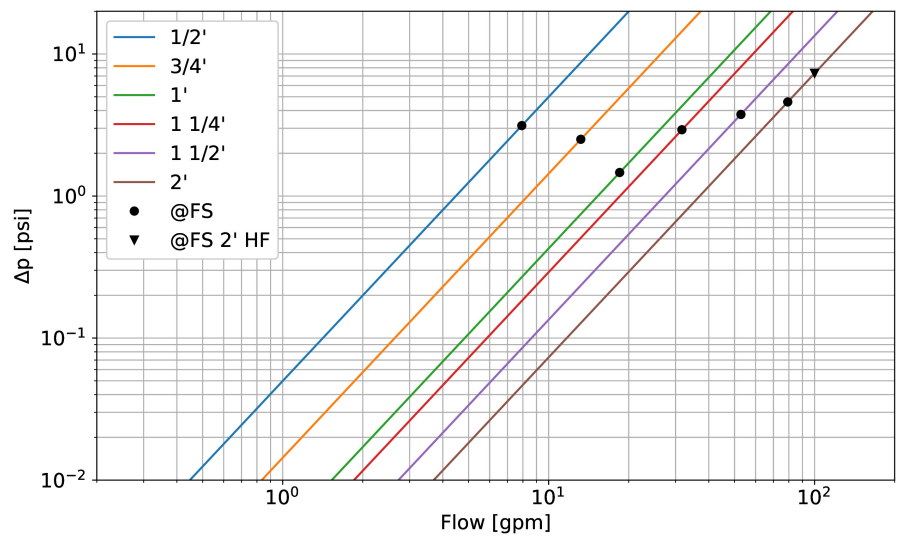

Product Features

Measuring accuracy Measuring accuracy for water (glycol 0% vol.):
 ±2% (@ 20...100% FS)
 At a temperature range of 15...120 °C.
 Measuring accuracy for water + glycol (glycol 0...60% vol.)
 ±5% (@ 20...100% FS)
 ±0.01 FS, but not more than 30% of q (@ 0.8...20% FS)
 At a temperature range of -20...120°C.



Installation notes

Permissible installation orientation The sensor can be installed upright to horizontal. The sensor may not be installed in a hanging position.

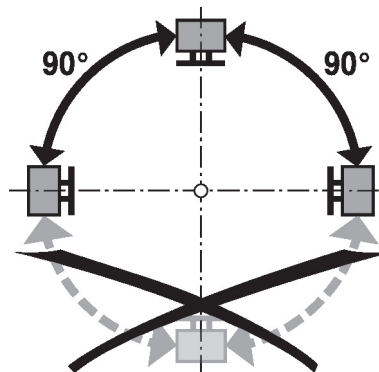

Installation in return Installation in the return is recommended.

Installation notes

Inlet section There are no requirements for straight inlet sections prior to the flow sensor. Product has been tested to and fulfills the requirements of EN1434-4:2022

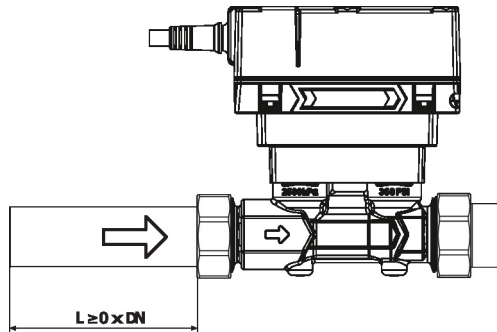

Water quality requirements The water quality requirements specified in VDI 2035 must be adhered to.

Servicing Sensors are maintenance-free.
 Before any service work on the sensor is carried out, it is essential to isolate the sensor from the power supply (by unplugging the electrical cables if necessary). Any pumps in the part of the piping system concerned must also be switched off and the appropriate slide valves closed (allow all components to cool down first if necessary and always reduce the system pressure to ambient pressure level).
 The system must not be returned to service until the sensor has been correctly reassembled in accordance with the instructions and the pipeline has been refilled by professionally trained personnel.

Flow direction The direction of flow, specified by an arrow on the housing, is to be complied with, since otherwise the flow rate will be measured incorrectly.

Avoiding cavitation To avoid cavitation, the system pressure at the outlet of the flow sensor must be a minimum of 1.0 bar at FS (maximum measurable flow) and temperatures up to 90°C.
 At a temperature of 120°C the system pressure at the outlet of the flow sensor must be at least 2.5 bar.

Cleaning of pipes Before installing the flow sensor, the loop must be thoroughly rinsed to remove impurities.

Prevention of stresses The flow sensor must not be subjected to excessive stress caused by pipes or fittings.

Accessories

Tools	Description	Type
	Service tool for wired and wireless setup, on-site operation and troubleshooting.	Belimo Assistant 2
	Converter Bluetooth / NFC	ZIP-BT-NFC

Service

- NFC connection** Belimo devices marked with the NFC logo can be operated with the Belimo Assistant 2.
- Requirement:
- NFC- or Bluetooth-capable smartphone
 - Belimo Assistant 2 (Google Play and Apple AppStore)
- Align NFC-capable smartphone on the device so that both NFC antennas are superposed.
- Connect Bluetooth-enabled smartphone via the Bluetooth-to-NFC converter ZIP-BT-NFC to the device. Technical data and operating instructions are shown in the ZIP-BT-NFC data sheet.
- Readable values: volumetric flow, accumulated flow, fluid temperature, glycol content in %, alarm/error messages

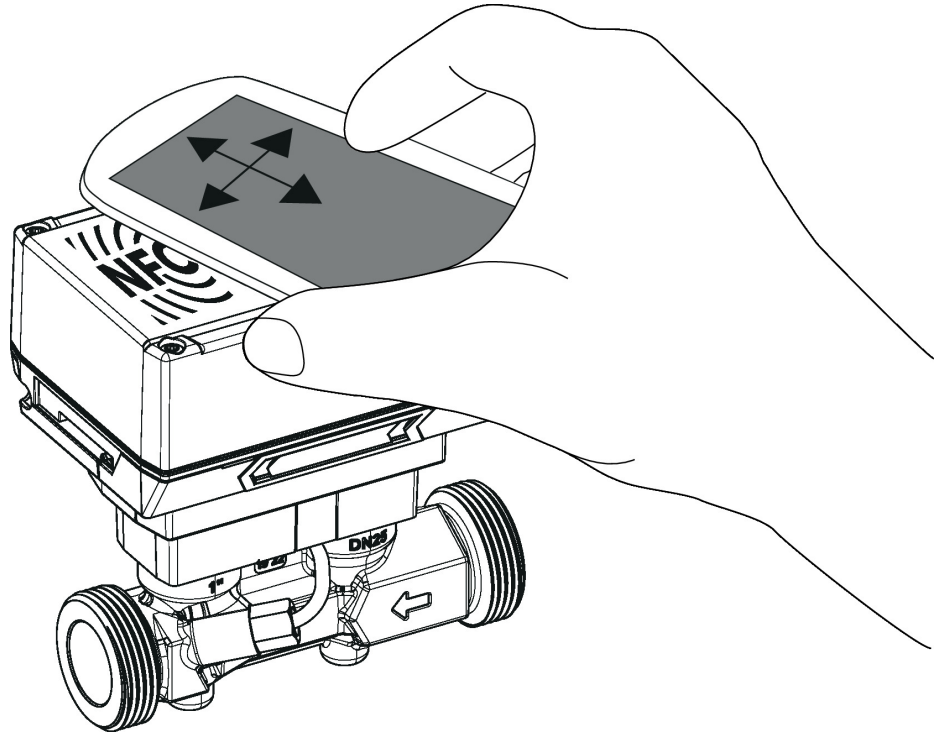

Wiring Diagram



Supply from isolating transformer.

The wiring of the line for BACnet MS/TP / Modbus RTU is to be carried out in accordance with applicable RS485 regulations.

Modbus / BACnet: Supply and communication are not a galvanic dry contact. Connect earth signal of the devices with one another.

Sensor connection: An additional sensor can optionally be connected to the flow sensor. This can be an active sensor with output DC 0...10 V (max. DC 0...32 V with resolution 30 mV) or a switching contact (switching current min. 16 mA @ 24 V). Thus the analogue signal of the sensor can be easily digitized with the flow sensor and transferred to the corresponding bus system.

Analogue output: An analogue output (wire 5) is available on the flow sensor. It can be selected as 0...10 V, 0.5...10 V, 2...10 V or user defined. For example, the flow rate or the temperature of the temperature sensor (Pt1000 - EN 60751, 2-wire technology) can be output as an analogue value.

Wiring Diagram

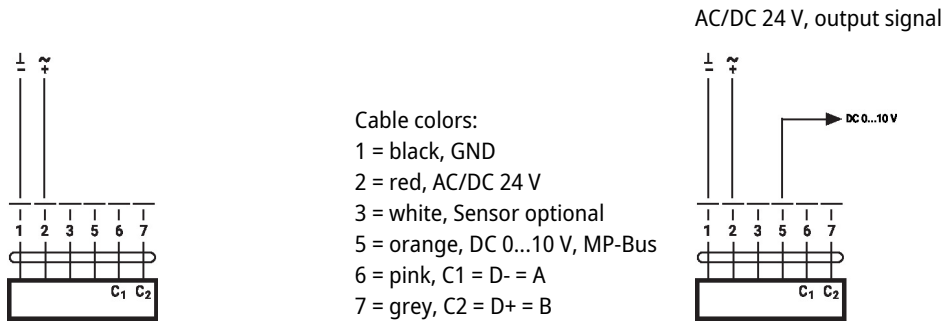

BACnet MS/TP / Modbus RTU

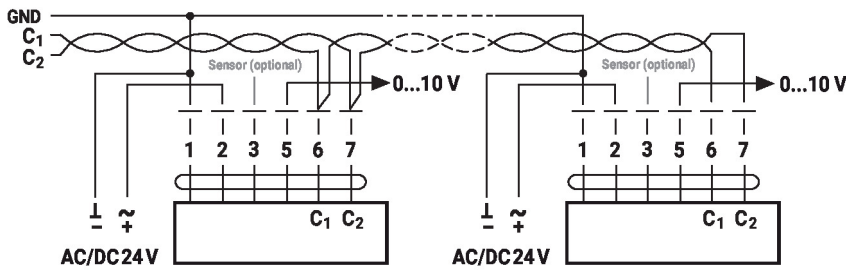

MP-Bus, supply via 3-wire connection

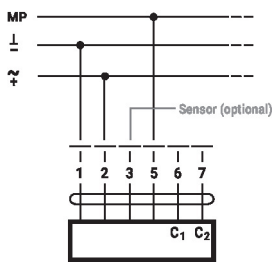

A) additional MP-Bus nodes
(max. 8)

MP-Bus via 2-wire connection, local power supply

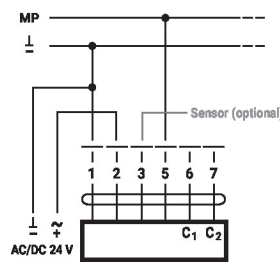

A) additional MP-Bus nodes
(max. 8)

Connection with active sensor

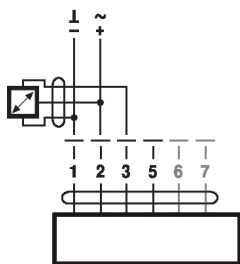

Connection with switching contact

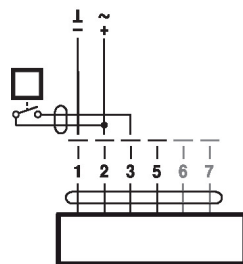

Dimensions

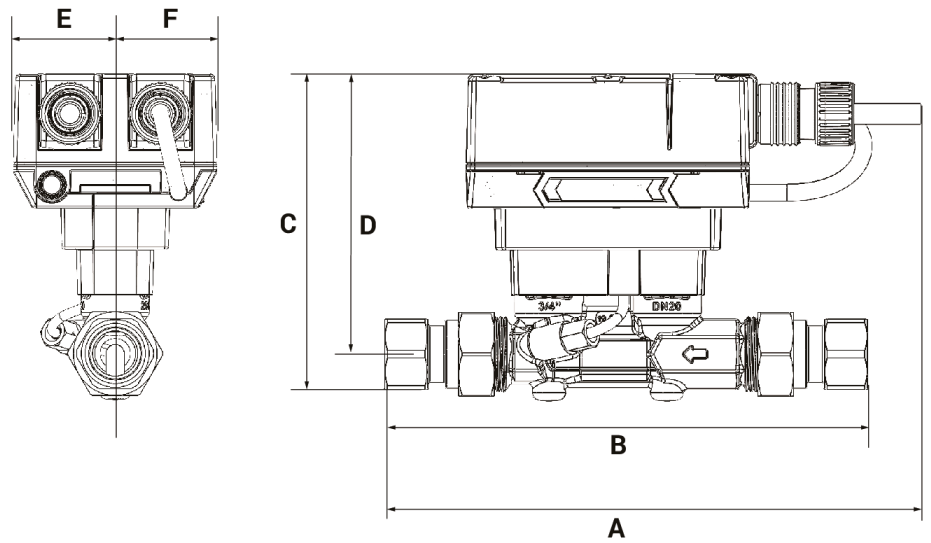

Type	DN	DN ["]	A	B	C	D	E	F	Weight
22PF-5UC	15	1/2	7.91" [200]	7.24" [183]	5.31" [134]	4.80" [121]	1.77" [44]	1.77" [44]	1.7 lb [0.750 kg]
22PF-5UD	20	3/4	8.15" [207]	8.35" [212]	5.47" [138]	4.88" [123]	1.77" [44]	1.77" [44]	1.7 lb [0.750 kg]
22PF-5UE	25	1	8.39" [213]	8.86" [225]	5.71" [145]	4.96" [125]	1.77" [44]	1.77" [44]	1.7 lb [0.750 kg]
22PF-5UF	32	1 1/4	8.70" [220]	9.45" [240]	6.06" [153]	5.12" [130]	1.77" [44]	1.77" [44]	1.7 lb [0.750 kg]
22PF-5UG	40	1 1/2	8.82" [224]	9.72" [246]	6.38" [162]	5.28" [134]	1.77" [44]	1.77" [44]	1.7 lb [0.750 kg]
22PF-5UH	50	2	8.23" [209]	8.54" [216]	6.85" [173]	5.47" [138]	1.77" [44]	1.77" [44]	1.7 lb [0.750 kg]
22PF-5UHH	50	2	8.23" [209]	8.54" [216]	6.85" [173]	5.47" [138]	1.77" [44]	1.77" [44]	1.7 lb [0.750 kg]

Further documentation

- Overview MP Cooperation Partners
- Description Data-Pool Values
- BACnet Interface description
- Modbus Interface description
- Installation instructions
- Quick Guide – Belimo Assistant 2