

c3controls' line of IEC terminal blocks are both innovative and user-friendly. They are simple to install and are color-coded for easy circuit identification. From standard feed-through spring clamp or screw clamp to disconnect, fuse holder, and power distribution terminal blocks, we've got what you need.

IEC TERMINAL BLOCKS

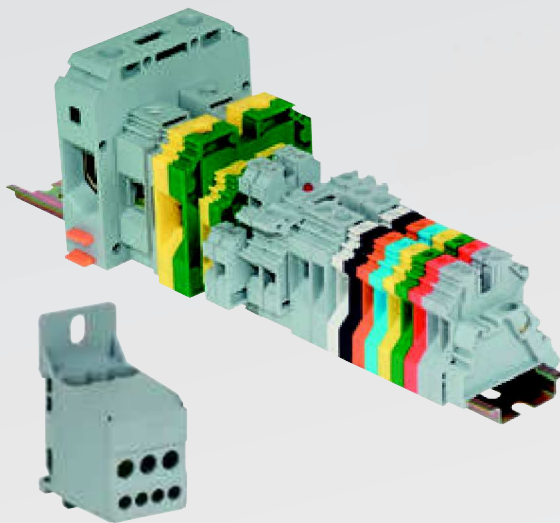

Screw Clamp Connection

- Feed Through DIN Rail
- Ground DIN Rail
- Multi-Conductor Feed Through DIN Rail
- Double Level Feed Through DIN Rail
- Triple Level Feed Through DIN Rail
- Fuse Holder DIN Rail
- Disconnect DIN Rail
- Power Distribution Block - Panel and DIN Rail Mount
- Miniature Feed Through Panel Mount



Spring Clamp Connection

- Feed Through DIN Rail
- Ground DIN Rail
- Multi-Conductor Feed Through DIN Rail
- Miniature Feed Through Panel Mount

Accessories & Markers

- Guide for Selecting Screw Driver Blade Dimension
- Plotter Systems & Accessories
- Dimensions

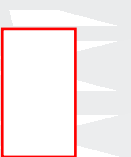

PROVEN



Conformity to Standards:

UL 1059, 486
CSA C22.2 No. 158-1987
IEC 60947-1, 60947-7-1

Certifications:

UL File #: E145984 (Guide XCFR2, XCFR8)
CE Marked (per EU Low Voltage Directive 2006/95/EC and
RoHS Directive 2011/65/EU)

Visit www.c3controls.com to download product certifications.

NOTE: The scope (range, description, price, specifications, dimensions, etc.) of the product featured in this section is subject to change without notice. Refer to www.c3controls.com for product updates.



IEC TERMINAL BLOCKS

c3controls offers a comprehensive line of IEC Terminal Blocks, and each one of our products is designed and manufactured to the needs of the machine builder. Check out all the features of our Series WTB2 below!

FOR DURABLE, SIMPLE, LONG-LASTING TERMINAL BLOCKS TURN TO C3CONTROLS.

✓ Proven	Our IEC terminal blocks meet UL and IEC standards requirements making them suitable for use in global applications.	
✓ Multiple Wire Sizes	Our IEC terminal blocks accept wires as small as 0.5mm ² (24 AWG) and as large as 120mm ² (4/0 AWG), and up to 232 amps.	
✓ Wide Range of Operation	A wide range of terminal blocks available from 5mm – 25mm in screw clamp, power distribution, and spring clamp, with ratings from 20A to 232A.	
✓ Vibration Resistant	The pre-loaded 302 stainless steel spring clamps hold the wire securely against the current bar and won't loosen, even in high vibration applications.	
✓ Heavy-Duty Construction	We mold our terminal block housings from unbreakable thermoplastic and we use quality zinc plated brass and electrolytic copper for our metal parts for excellent conductivity and to minimize corrosion.	
✓ Visible Certifications	Our product certifications and electrical ratings are clearly marked on the outside of the terminal blocks for easy reference during installation.	
✓ Quick Identification	Color coded blocks and terminal markers are available for easy circuit identification.	
✓ Time & Space Savings	Internal jumpers in up to 10 positions free up valuable wiring space and reduce assembly time.	
✓ Lifetime Warranty*	Every product is backed by our lifetime warranty—unmatched in the industry—bringing you quality components that perform in the most demanding applications.	
✓ Guaranteed Same-Day Shipping*	Product availability reduces inventory, and improves cash-flow—saving you money. With c3controls any order for standard catalog items received by 6:00pm ET is guaranteed to ship same-day.	
✓ Advantage Pricing	Our approach to product development, manufacturing, and focus on servicing the OEM and Electrical Equipment Builder reduces cost. The result—the best value in the industry.	

*See c3controls Terms & Conditions

“ c3controls has helped us reduce the costs on all of our control panel components. From terminal blocks, power disconnects, selector and push button switches, to motor contactors and overload relays, c3controls' products are all we use. ”

Joel Fritz, President & CEO • Pacific Kiln & Insulations, Co. Inc.

WE DIDN'T INVENT CONTROL, WE'RE PERFECTING IT.

IEC Screw Clamp Multi-Level DIN Rail



IEC Screw Clamp Power Distribution



IEC Spring Clamp Ground DIN Rail

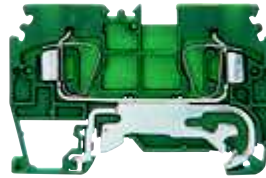

IEC Spring Clamp Multi-Conductor Feed Through DIN Rail

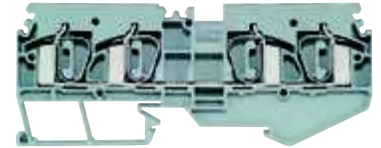

UNIQUE PRODUCT LINE FEATURES

SECURITY

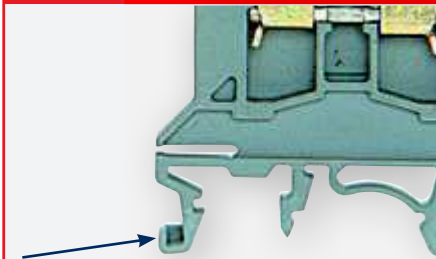

Our snap-on, rugged DIN rail mounting foot is designed to easily attach terminal blocks while creating a secure fit.

SAFETY

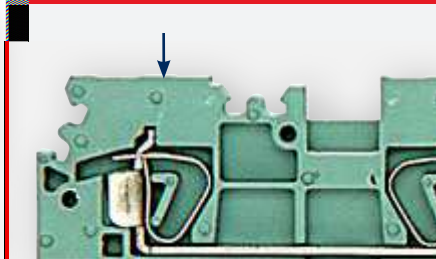

All c3controls terminal blocks come with IP20 protection against accidental contact.

STABILITY



Our screw clamp terminal blocks feature a vibration resistant zinc plated clamping system.

WIRING MADE EASY



The funnel entry design of our terminal blocks makes wiring easy and our spring clamp features top wiring.

CIRCUIT IDENTIFICATION



Marking system allows for fast and easy circuit identification. Blank, custom, and standard markers are available.

RECESSED TERMINAL SCREWS

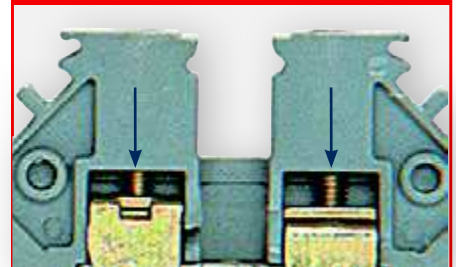

Captive terminal screws are recessed to avoid accidental contact and will not fall out during wiring.

FIND IT FAST

IEC Terminal Blocks



- Certifications
- Specifications
- Dimension Drawings
- Installation Instructions
- Easy To Buy

www.c3controls.com

IEC FEED THROUGH DIN RAIL TERMINAL BLOCKS

c3controls WTB2 Series of feed through terminal blocks have been designed to meet the strict specifications and standards of UL, CSA, and IEC. The WTB2 Series of terminal blocks is manufactured with a direct mounting foot for 32mm and 35mm standard DIN rails.

In addition to the mounting feature, the WTB2 Series is constructed using only the best available materials for both the housing and clamping bodies and parts. The housing is molded out of an unbreakable high quality thermoplastic. The metal bodies are made of a high quality zinc plated, brass and electrolytic copper to provide excellent conductivity and minimize corrosion problems.

The WTB2 Series accepts wires as small as 0.5mm² (24 AWG) and as large as 120mm² (4/0 AWG), up to 232 Amps. Wiring to the terminal blocks is made easy by the funnel entry design of the housing. Accessories such as circuit bridges, end plates, partition plates, and markers make the WTB2 Series a flexible alternative to any feed through wiring or power distribution application.

SPECIAL FEATURES

C3CONTROLS MANUFACTURES THE MOST INNOVATIVE, USER-FRIENDLY LINE OF TERMINAL BLOCKS ON THE MARKET TODAY!

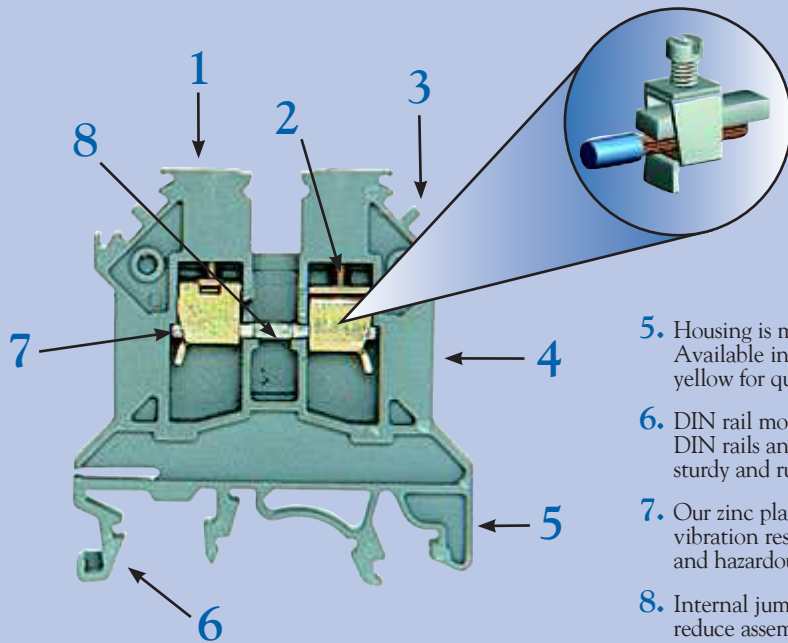

1. Construction provides IP20 protection to guard against accidental contact with live parts — even with accessories installed.
2. Captive terminal screws will not fall out during wiring and are recessed to avoid accidental contact.
3. Marking system allows for fast and easy circuit identification. Blank, custom, and standard markers are available.
4. Funneled wiring entry with finger safe IP20 terminals simplifies wiring for fast and easy installations.
5. Housing is molded out of an unbreakable high quality thermoplastic. Available in eight colors; grey, black, blue, green, orange, red, white, and yellow for quick identification of control circuit types.
6. DIN rail mounting foot allows for direct mounting on 32mm and 35mm DIN rails and is designed for easy snap on, snap off assembly — the most sturdy and rugged mounting foot on the market!
7. Our zinc plated clamping system provides superior conductivity, is vibration resistant, and offers superb corrosion resistance for normal and hazardous environments.
8. Internal jumpers (circuit bridges) free up valuable wiring space and reduce assembly time.

ADDITIONAL COLORS AVAILABLE FOR IEC TERMINAL BLOCKS



IEC FEED THROUGH DIN RAIL TERMINAL BLOCKS

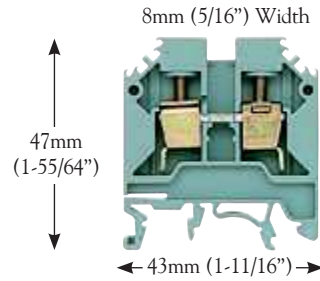

WTB2-W6

SPECIFICATIONS		SINGLE-CIRCUIT TERMINAL BLOCK	
Certifications		 UL 1059 File #: E145984	 IEC 60947-7-1
Voltage Rating (V)		600	750
Maximum Current (A)		50	41
WIRE RANGE			
Solid Strand Conductor	mm ²	1.5 - 10	
Fine Strand Conductor	mm ²	1.5 - 6	
AWG Conductor		22 - 8	
Wire Strip Length	(mm/inches)	12 / 0.47	
Tightening Torque	(Nm/Lb-in)	0.8 / 9	
OPERATING TEMPERATURE			
Operating Temperature		-20 to +80° C (-4 to +176° F)	
ROHS COMPLIANCE			
For RoHS compliance documentation by product, refer to www.c3controls.com			
TERMINAL BLOCKS		CAT. NO.	PCS./PKG.
(Standard) Grey		WTB2-W6	100
Black		WTB2-W6-BK	100
Blue		WTB2-W6-BE	100
Green		WTB2-W6-GN	100
Orange		WTB2-W6-OR	100
Red		WTB2-W6-RD	100
White		WTB2-W6-WH	100
Yellow		WTB2-W6-YW	100
ACCESSORIES (see pages 444-446)		CAT. NO.	PCS./PKG.
End Barrier			
Grey, Non-Metallic (Installs on 35mm DIN Rail)		WTB2-EB	50
Grey, Non-Metallic (Installs on 32mm and 35mm DIN Rail)		WTB2-EB2	50
Steel (Installs on 35mm DIN Rail)		WTB2-EB3	50
Circuit Bridge			
2 Position		WTB2-W6/2CB	10
3 Position		WTB2-W6/3CB	10
4 Position		WTB2-W6/4CB	10
10 Position		WTB2-W6/10CB	10
End Plate		WTB2-EPW6/10	50
Separator Plate		WTB2-AD6/10	50
Partition Plate		WTB2-PPW6/10	50
Marker		WTB2-M8	100
Group Markers (see page 444)			
Plated Steel Mounting Rail, DIN			
35mm x 7.5mm - Slotted - 1 Meter		DRMR3	1
35mm x 7.5mm - Slotted - 2 Meters		DRMR6	10
35mm x 15mm - Slotted - 1 Meter		DRMR3D	1
35mm x 15mm - Slotted - 2 Meters		DRMR6D	1
Aluminum Mounting Rail, DIN			
35mm x 7.5mm - Slotted - 1 Meter		DRMR3A	1
DIN Rail Support Bracket		WTB2-BRKT1	1



SEE BOTTOM OF PAGE 418 FOR COLOR OPTIONS.

WE DIDN'T INVENT CONTROL, WE'RE PERFECTING IT.

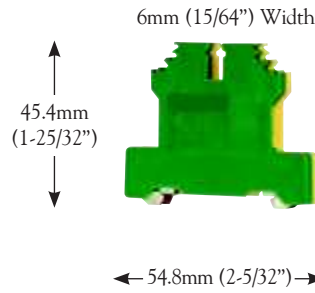
IEC GROUND DIN RAIL TERMINAL BLOCKS



WTB2-W2/4G

SPECIFICATIONS		SINGLE-CIRCUIT TERMINAL BLOCK	
Certifications		 UL 1059 File #: E145984	 IEC 60947-7-2
WIRE RANGE			
Solid Strand Conductor	mm ²	0.5 - 6	
Fine Strand Conductor	mm ²	0.5 - 4	
AWG Conductor		22 - 12	
Wire Strip Length	(mm/inches)	9 / 0.35	
Tightening Torque	(Nm/Lb-in)	0.5 / 7	
OPERATING TEMPERATURE			
Operating Temperature		-20 to +80° C (-4 to +176° F)	
ROHS COMPLIANCE		For RoHS compliance documentation by product, refer to www.c3controls.com	
TERMINAL BLOCKS		CAT. NO.	PCS./PKG.
Yellow and Green insulation housing with metal mounting foot.		WTB2-W2/4G	50
ACCESSORIES (see pages 444-446)		CAT. NO.	PCS./PKG.
End Barrier			
	Grey, Non-Metallic (Installs on 35mm DIN Rail)	WTB2-EB	50
	Grey, Non-Metallic (Installs on 32mm and 35mm DIN Rail)	WTB2-EB2	50
	Steel (Installs on 35mm DIN Rail)	WTB2-EB3	50
Marker		WTB2-M6	100
Group Markers (see page 444)			
Plated Steel Mounting Rail, DIN			
	35mm x 7.5mm - Slotted - 1 Meter	DRMR3	1
	35mm x 7.5mm - Slotted - 2 Meters	DRMR6	10
	35mm x 15mm - Slotted - 1 Meter	DRMR3D	1
	35mm x 15mm - Slotted - 2 Meters	DRMR6D	1
Aluminum Mounting Rail, DIN			
	35mm x 7.5mm - Slotted - 1 Meter	DRMR3A	1
DIN Rail Support Bracket		WTB2-BRKT1	1

IEC FUSE HOLDER DIN RAIL TERMINAL BLOCKS

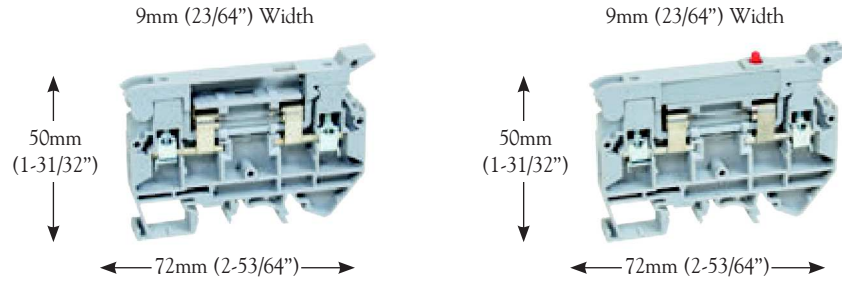

NOTE: The WTB2-FB1L has a red LED that glows to indicate a blown fuse.

WTB2-FB1

WTB2-FB1L^①

SPECIFICATIONS	1/4" X 1-1/4" FUSE		1/4" X 1-1/4" FUSE	
	UL 1059 File #: E145984	CE IEC 60947-7-3	UL 1059 File #: E145984	CE IEC 60947-7-3
Certifications				
Voltage Rating (V)	600	600	600	600
Maximum Current (A)	6.3	6.3	6.3	6.3
WIRE RANGE				
Solid Strand Conductor mm ²	0.5 - 6		0.5 - 6	
Fine Strand Conductor mm ²	0.5 - 4		0.5 - 4	
AWG Conductor	22 - 10		22 - 10	
Wire Strip Length (mm/inches)	9.5 / 0.37		9.5 / 0.37	
Tightening Torque (Nm/Lb-in)	0.5 / 7		0.5 / 7	
OPERATING TEMPERATURE				
Operating Temperature	-20 to +80° C (-4 to +176° F)		-20 to +80° C (-4 to +176° F)	
ROHS COMPLIANCE				
	For RoHS compliance documentation by product, refer to www.c3controls.com			
TERMINAL BLOCKS				
	CAT. NO.	PCS./PKG.	CAT. NO.	PCS./PKG.
(Standard) Grey	WTB2-FB1	25	—	—
(Standard) Grey for 24V AC/DC	—	—	WTB2-FB1L24	10
(Standard) Grey for 110V AC/DC	—	—	WTB2-FB1L110	10
(Standard) Grey for 220V AC	—	—	WTB2-FB1L220	10
ACCESSORIES (see pages 444-446)				
	CAT. NO.	PCS./PKG.	CAT. NO.	PCS./PKG.
End Barrier				
Grey, Non-Metallic (Installs on 35mm DIN Rail)	WTB2-EB	50	WTB2-EB	50
Grey, Non-Metallic (Installs on 32mm and 35mm DIN Rail)	WTB2-EB2	50	WTB2-EB2	50
Steel (Installs on 35mm DIN Rail)	WTB2-EB3	50	WTB2-EB3	50
End Plate	WTB2-EPFB1	50	WTB2-EPFB1	50
Marker	WTB2-M9	100	WTB2-M9	100
Group Markers (see page 444)				
Plated Steel Mounting Rail, DIN				
35mm x 7.5mm - Slotted - 1 Meter	DRMR3	1	DRMR3	1
35mm x 7.5mm - Slotted - 2 Meters	DRMR6	10	DRMR6	10
35mm x 15mm - Slotted - 1 Meter	DRMR3D	1	DRMR3D	1
35mm x 15mm - Slotted - 2 Meters	DRMR6D	1	DRMR6D	1
Aluminum Mounting Rail, DIN				
35mm x 7.5mm - Slotted - 1 Meter	DRMR3A	1	DRMR3A	1
DIN Rail Support Bracket	WTB2-BRKT1	1	WTB2-BRKT1	1

①with LED indication

END PLATES

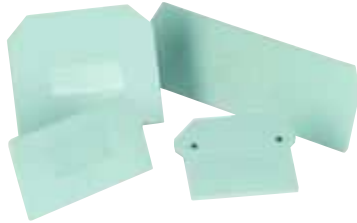

Our end plates enclose the open side of the last terminal block in a rail assembly to provide isolation from adjacent equipment and circuits. May also be used as a separator to divide circuits in a terminal block rail assembly. See applicable terminal block page for end plate part number and ordering information.

SEPARATOR PLATES



Our separator plate is used to divide circuits in a terminal block rail assembly. See applicable terminal block page for separator plate part number and ordering information.

PARTITION PLATES



Our partition plates are used to identify and segregate terminal block groups. In addition, they maintain the required creepage and clearance for electrical isolation. See applicable terminal block page for partition plate part number and ordering information.

END BARRIERS



Our end barriers retain the terminal blocks on the mounting rail. See applicable terminal block page for end barrier part number and ordering information.

DIN RAIL



We offer two types of 35mm symmetrical DIN rails; steel and aluminum. Our steel DIN rail is zinc with clear chromate plated and is available in either 1m (3.28ft.) or 2m (6.56ft.). The aluminum version is available in 1m (3.28ft.). Each simply fasten by screws to the mounting surface - no special brackets or hardware are needed. Terminal blocks easily snap on to rail. See applicable terminal block page for DIN rail part number and ordering information.

DIN RAIL SUPPORT BRACKET



Angled bracket raises DIN rail off of mounting panel for easier more convenient wiring of terminal blocks. See applicable terminal block page for support bracket part number and ordering information.

CIRCUIT BRIDGES

Internal, Insulated – for Screw Clamp Connection Terminal Blocks



Use our insulated circuit bridges to electrically connect multiple terminal blocks. Our circuit bridges are pre-assembled and available in 2-, 3-, 4-, and 10-position. See applicable terminal block page for circuit bridge part number and ordering information.

Insulated Push-In – for Spring Clamp Connection Terminal Blocks



Our insulated push-in circuit bridges provide IP20 protection and simplify the task of cross connection between multiple terminal blocks. Circuit bridges are available for connections between adjacent and alternate terminal blocks. See applicable terminal block page for circuit bridge part number and ordering information.

CIRCUIT BRIDGE INSTALLATION AND REMOVAL TOOL



For easy installation and removal of circuit bridges with adjacent terminal blocks. See applicable terminal block page for circuit bridge installation tool part number and ordering information.

GROUP MARKERS

Our group markers and group marker holders are used to identify an assembly of adjacent terminals that are associated with a specific function, control circuit, or part of a machine.

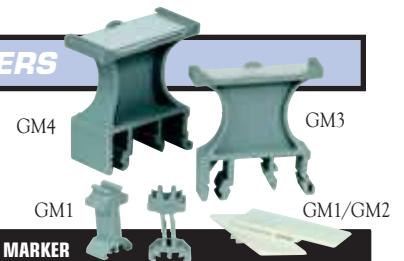

GROUP MARKER HOLDER	FOR USE WITH	MARKER	CODE
WTB2-GM1	WTB2-EB End Barrier	WTB2-M8	WTB2-MGM1
WTB2-GM2	WTB2-EB End Barrier	WTB2-M8	WTB2-MGM1
WTB2-GM3 ^①	32mm or 35mm DIN Rail	—	—
WTB2-GM4 ^①	32mm or 35mm DIN Rail	—	—
WTB2-MGM2	WTB2-MW4	—	—

^① Includes a paper label.

IT'S EASY TO BUILD YOUR OWN TERMINAL MARKERS

Simply pick the code number from each of the sections below and combine them to build your part number.

IEC Terminal Block Markers

WTB2- I II III IV V

Example: To build one of our most popular Terminal Markers, the part number would be **WTB2 + II + III + IV + V** or **WTB2-M5LIAVL**



I. MARKER TYPE

CODE	DESCRIPTION
WTB2	IEC Terminal Block Marker

II. MARKER DIMENSION

CODE	DESCRIPTION (W X HT)	MARKERS PER STRIP	STRIPS PER PKG.	MARKERS PER PKG.
M2	6mm x 5mm Marker	10	10	100
M5A	5mm x 5mm Marker	10	10	100
M5	5mm x 10mm Marker	10	10	100
M6	6mm x 10mm Marker	10	10	100
M8	8mm x 11mm Marker	10	10	100
M9	9mm x 10mm Marker	10	10	100
M10A	10mm x 5mm Marker	10	10	100
M10	10mm x 11mm Marker	5	20	100
M12	12mm x 11mm Marker	5	20	100
M15	15mm x 11mm Marker	5	20	100
M50	20mm x 5mm Marker	1	10	10

SEE PAGE 446 FOR MARKER ORIENTATION.

III. SERIES MARKER OPTIONS

SERIES MARKER OPTIONS

A. NUMBERS

CODE	DESCRIPTION	NO. OF SETS/MARKERS PER PACKAGE:†	NO. OF SETS/MARKERS PER PACKAGE:††
(Blank)	(Blank)	10/100	10/100
NS01-10	1 - 10	10/100	10/100
NS11-20	11 - 20	10/100	10/100
NS21-30	21 - 30	10/100	10/100
NS31-40	31 - 40	10/100	10/100
NS41-50	41 - 50	10/100	10/100
NS51-60	51 - 60	10/100	10/100
NS61-70	61 - 70	10/100	10/100
NS71-80	71 - 80	10/100	10/100
NS81-90	81 - 90	10/100	10/100
NS91-100	91 - 100	10/100	10/100
NS01-20	1 - 20	5/100	5/100
NS21-40	21 - 40	5/100	5/100
NS41-60	41 - 60	5/100	5/100
NS61-80	61 - 80	5/100	5/100
NS81-100	81-100	5/100	5/100
NS01-100	1-100	1/100	1/100

B. SPECIAL SYMBOLS AND CHARACTERS

CODE	DESCRIPTION	NO. OF SETS/MARKERS PER PACKAGE:†	NO. OF SETS/MARKERS PER PACKAGE:††
(Blank)	(Blank)	10/100	10/100
SS01	L1, L2, L3 T1, T2, T3	15/90	10/60
SS02	1, 3, 5 2, 4, 6	15/90	10/60
SS03	+ , - , ⊕	30/90	20/60
SS04	+ , - , GND	30/90	20/60

C. LETTERS

CODE	DESCRIPTION	NO. OF SETS/MARKERS PER PACKAGE:†	NO. OF SETS/MARKERS PER PACKAGE:††
(Blank)	(Blank)	10/100	10/100
LSA-J	A - J	10/100	10/100
LSK-T	K - T	10/100	10/100
LSQ-Z	Q - Z	10/100	10/100
LSG-P	G - P	10/100	10/100
LSA-T	A - T	5/100	5/100
LSG-Z	G - Z	5/100	5/100

†WTB2-M2, M5A, M5, M6, M8, M9, M10A, M10 ††WTB2-M12, M15

INDIVIDUAL MARKER OPTIONS

A. NUMBERS

CODE	DESCRIPTION	NO. OF SETS/MARKERS PER PACKAGE:†	NO. OF SETS/MARKERS PER PACKAGE:††
(Blank)	(Blank)	10/100	20/100
NI00	0	10/100	20/100
NI01	1	10/100	20/100
NI02	2	10/100	20/100
NI03	3	10/100	20/100
NI04	4	10/100	20/100
NI05	5	10/100	20/100
NI06	6	10/100	20/100
NI07	7	10/100	20/100
NI08	8	10/100	20/100
NI09	9	10/100	20/100
NI10	10	10/100	20/100

B. SPECIAL SYMBOLS AND CHARACTERS

CODE	DESCRIPTION	NO. OF SETS/MARKERS PER PACKAGE:†	NO. OF SETS/MARKERS PER PACKAGE:††
(Blank)	(Blank)	10/100	20/100
SI01	L1	10/100	20/100
SI02	L2	10/100	20/100
SI03	L3	10/100	20/100
SI04	T1	10/100	20/100
SI05	T2	10/100	20/100
SI06	T3	10/100	20/100
SI07	+	10/100	20/100
SI08	-	10/100	20/100
SI09	GND	10/100	20/100
SI10	⊕	10/100	20/100
SI11	~	10/100	20/100
SI12	—	10/100	20/100

C. LETTERS

CODE	DESCRIPTION	NO. OF SETS/MARKERS PER PACKAGE:†	NO. OF SETS/MARKERS PER PACKAGE:††
(Blank)	(Blank)	10/100	20/100
LIA	A	10/100	20/100
LIB	B	10/100	20/100
LIC	C	10/100	20/100
LID	D	10/100	20/100
LIE	E	10/100	20/100
LIF	F	10/100	20/100
LIG	G	10/100	20/100
LIH	H	10/100	20/100
LIJ	I	10/100	20/100
LIJ	J	10/100	20/100
LIK	K	10/100	20/100
LIL	L	10/100	20/100
LIM	M	10/100	20/100
LIN	N	10/100	20/100
LIO	O	10/100	20/100
LIP	P	10/100	20/100
LIQ	Q	10/100	20/100
LIR	R	10/100	20/100
LIS	S	10/100	20/100
LIT	T	10/100	20/100
LIU	U	10/100	20/100
LIV	V	10/100	20/100
LIW	W	10/100	20/100
LIX	X	10/100	20/100
LIY	Y	10/100	20/100
LIZ	Z	10/100	20/100

IV. ORIENTATION OPTIONS

CODE	DESCRIPTION
(Blank)	—
H	Printed w/Horizontal Orientation
V	Printed w/Vertical Orientation

V. LETTER CASE OPTIONS

CODE	DESCRIPTION
(Blank)	—
U	Uppercase (Capital) Letters
L	Lowercase Letters

SCREW CLAMP FEED THROUGH

WTB2-W2 (25A)

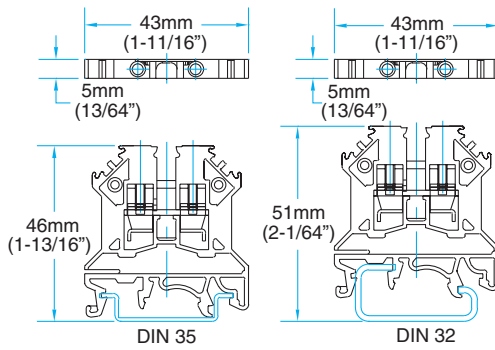

WTB2-W4 (35A)

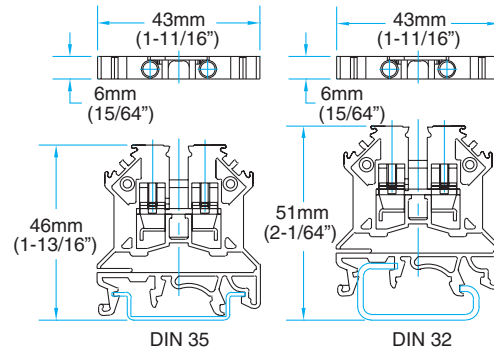

WTB2-W6 (50A)

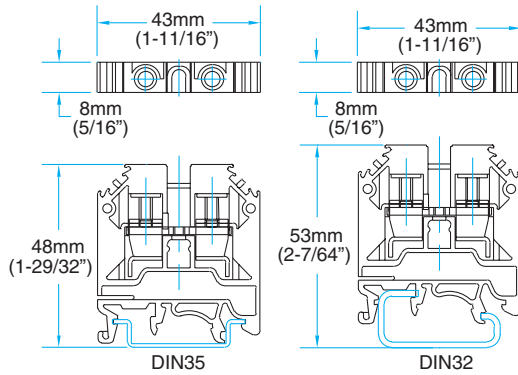

WTB2-W10 (65A)

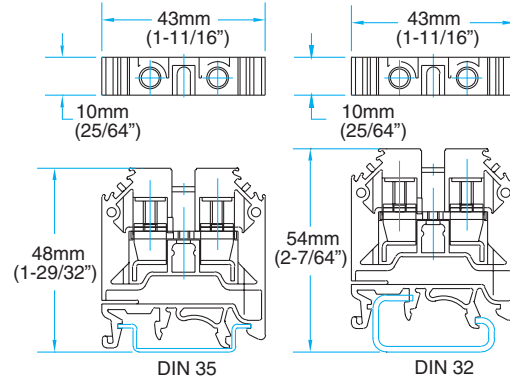

WTB2-W16 (85A)

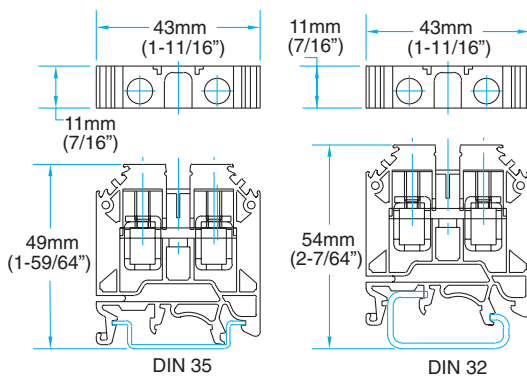

WTB2-W25 (115A)

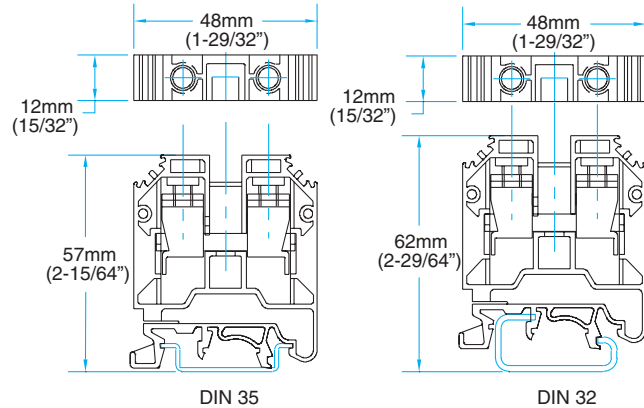

VISIT WWW.C3CONTROLS.COM
TO DOWNLOAD CAD DRAWINGS

SCREW CLAMP FEED THROUGH (CONT.)

WTB2-W35 (145A)

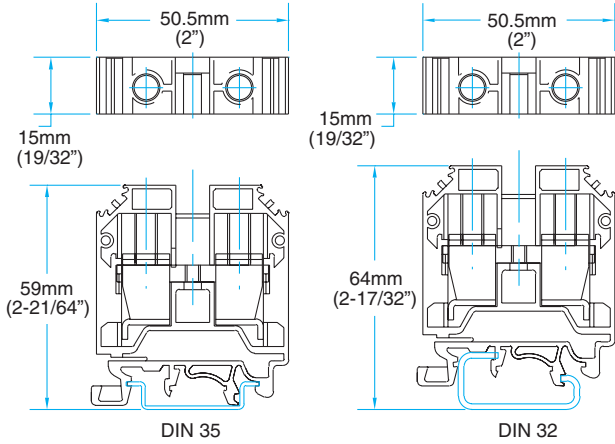

SCREW CLAMP GROUND

WTB2-W2/4G

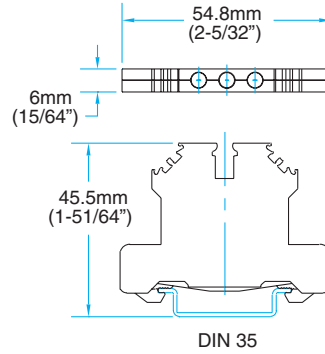

WTB2-W70 (150A)

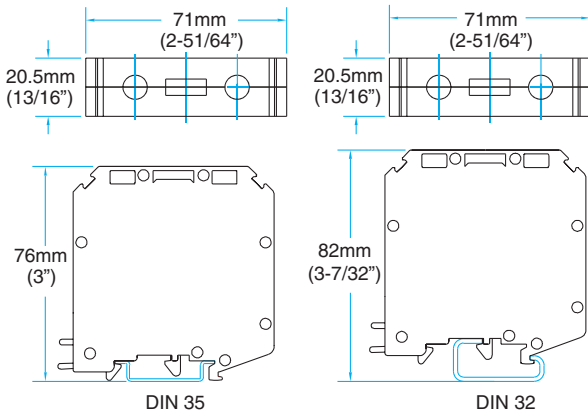

WTB2-W6/10G

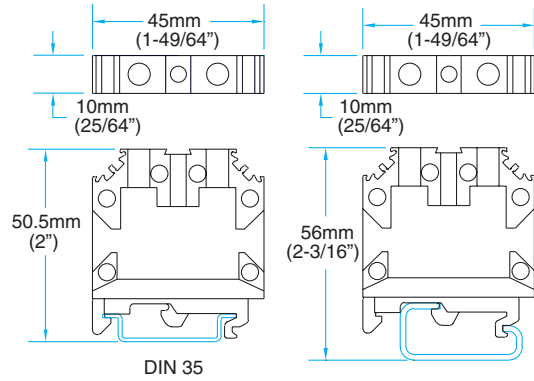

WTB2-W95 (230A)

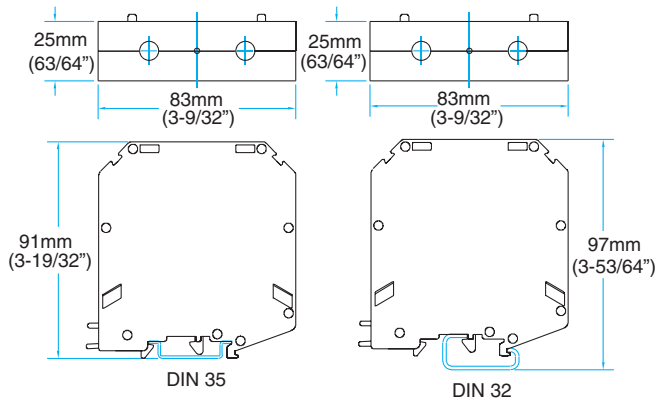

WTB2-W16/35G

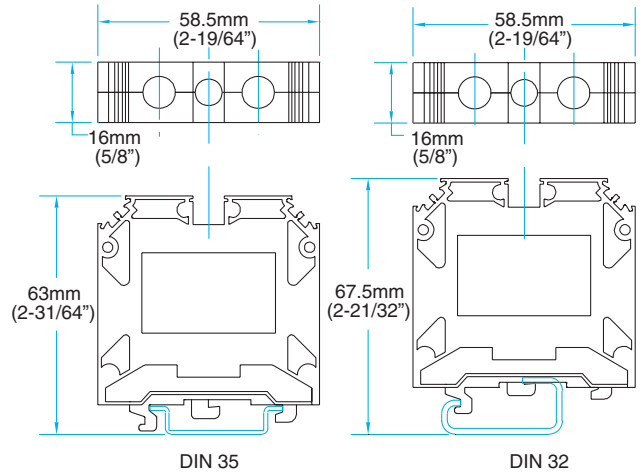

SCREW CLAMP END PLATES

WTB2-EPW2/4

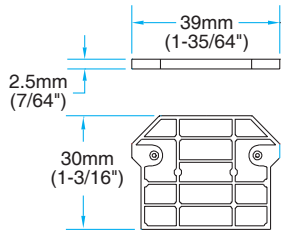

WTB2-EPW6/10

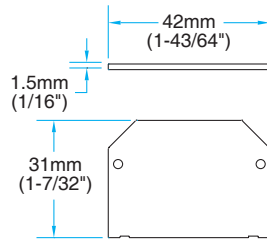

WTB2-EPW25

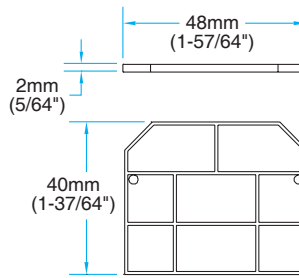

WTB2-EPW35

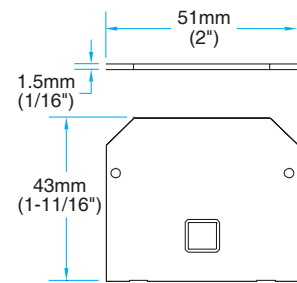

WTB2-EPW4-12

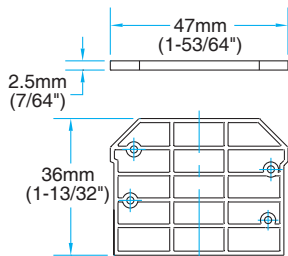

WTB2-EPW4-22

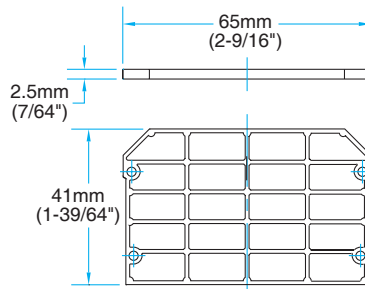

WTB2-EPW4DD

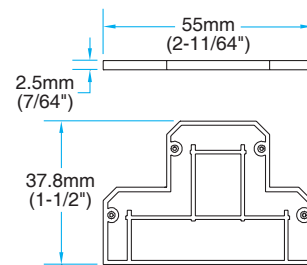

WTB2-EPTL2

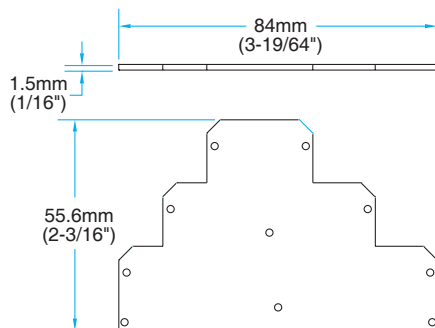

WTB2-EPTL2S

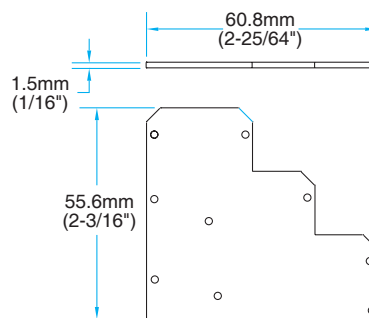

WTB2-EPFB1

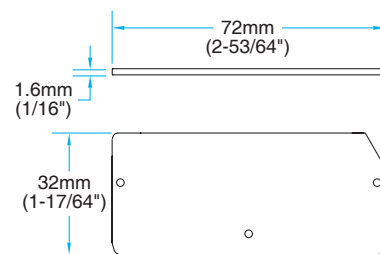

WTB2-EPFB52

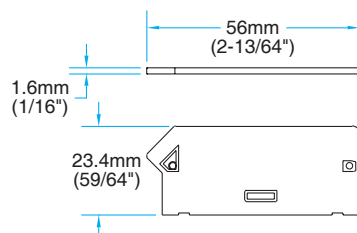

WTB2-EPDB1

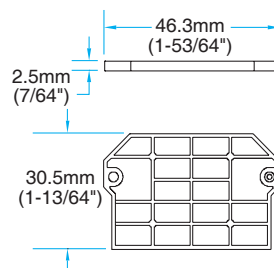

WTB2-EPMW4

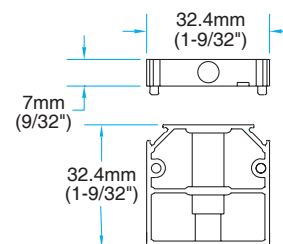

SCREW CLAMP PARTITION PLATES

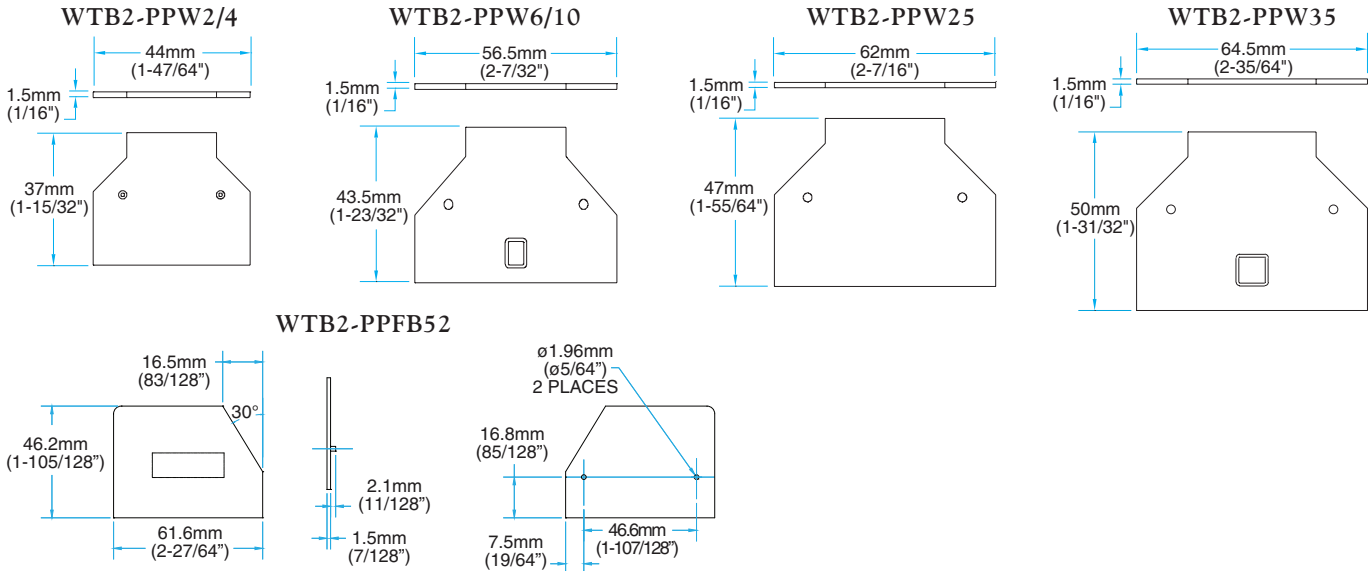

END BARRIERS FOR SCREW CLAMP & SPRING CLAMP TERMINAL BLOCKS

DIN RAIL SUPPORT BRACKET FOR SCREW CLAMP & SPRING CLAMP TERMINAL BLOCKS

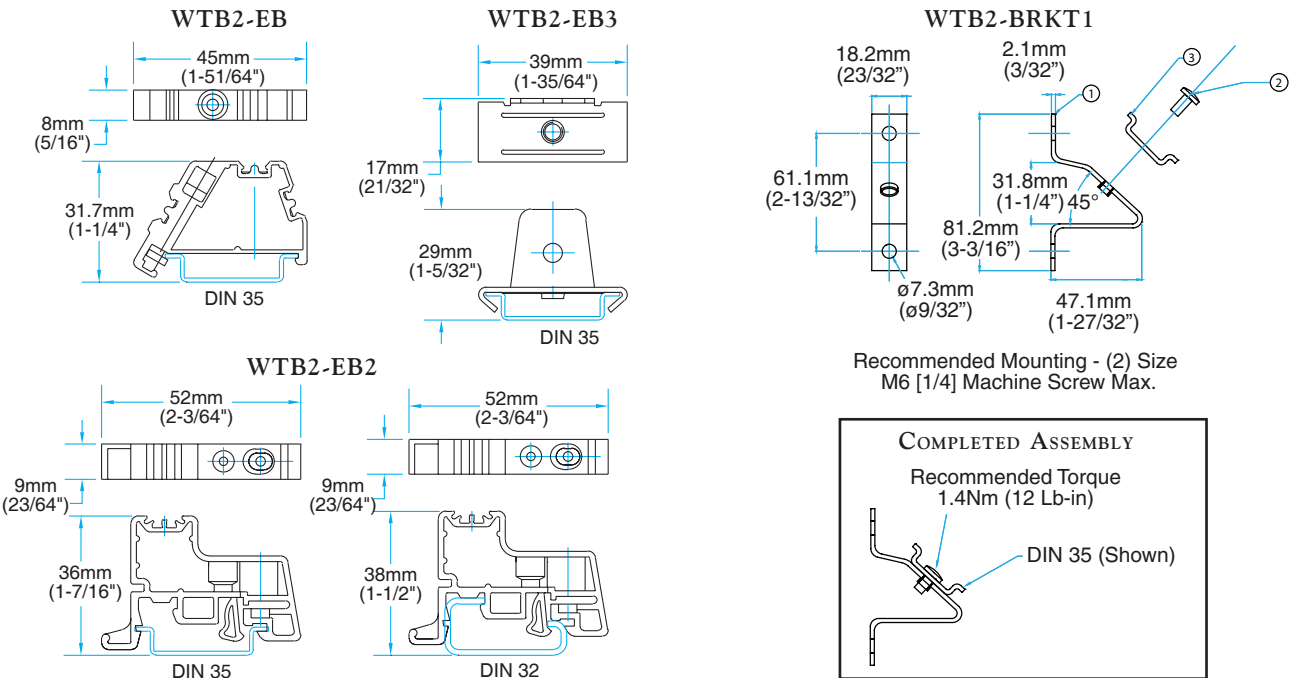

SPRING CLAMP FEED THROUGH

