

# B1 20, B277, B347 Power Packs



**TURN THE POWER OFF AT THE CIRCUIT BREAKER BEFORE  
INSTALLING POWER/SLAVE PACKS!**

**ONLY QUALIFIED ELECTRICIANS SHOULD ATTEMPT TO INSTALL  
WATT STOPPER® POWER/SLAVE PACKS!**

The power pack is attached to existing junction boxes. All low voltage wiring should be at least 22 gauge wire. All high voltage connections should be at least 14 gauge. Always check local building codes. After initial wiring is complete, check to verify power pack is wired correctly. Improper wiring can cause damage to power pack, lighting system, and occupancy sensor.

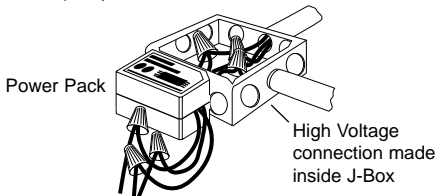

**Two phase  
circuit lighting  
with two loads**

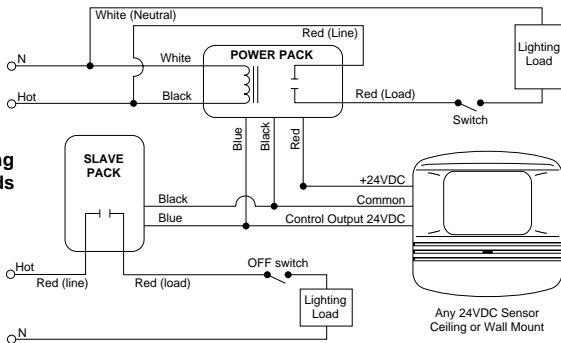

Technical Support:  
(800) 879-8585 (972) 578-1699

70-0031-00r2 1/00

Installation Instructions