

Cerus X-Drive

Physical Installation

Environmental Requirements

NOTICE

Risk of damage to VFD, or malfunction can occur due to improper handling, installation, or environment.

- Do not mount VFD on equipment with excessive vibration.
- Install in a location where temperature is within the range of product rating.
- Install VFD on a non-combustible surface. The VFD generates heat during normal operation.
- The VFD should be mounted in a Pollution Degree 2 environment. If VFD will be installed in an environment with a high probability of dust, metallic particles, mists, corrosive gas or other contaminants, the VFD must be mounted inside the appropriate electrical enclosure with proper NEMA, UL or IP rating and adequate cooling.
- When two or more VFDs are installed in a ventilated enclosure, the cooling system should provide adequate airflow for all the VFDs. Do not install VFD above another heat source (another VFD, inductive reactors, etc.).

This **QuickStart Guide** includes basic setup and operation information.

For detailed instructions and safety information, please refer to the **Cerus X-Drive Installation and Operation Manual**
www.franklin-controls.com.

The VFD must be installed and used in a controlled environment that meets the following requirements:

Ambient Temperature	50 °C (122 °F) UL Open Type/IP20 (Top cover must be removed.) 40 °C (113 °F) in NEMA 3R/IP14 enclosure 40 °C (104 °F) in NEMA 1/IP10 enclosure.
Location	Pollution Degree 2 Environment.
Altitude	1000m (3281ft) above sea level. De-rate 1% per 100m (328ft) from 1000 to 2000m (3281-6562ft). De-rate 2% per 100m (328ft) for installations from 2000-3000m (6560-9840ft). Consult factory for installations above 3000m.
Relative Humidity	95% Maximum relative humidity (non-condensing)
Vibration	1.0mm, peak to peak value range from 2 Hz to 13.2 Hz 0.7G-1.0G range from 13.2 Hz to 55 Hz 1.0G range from 55 Hz to 512 Hz.

The drive electronics are air-cooled. Provide enough clearance for an airflow around the VFD.

Mount VFD vertically (top up) for proper heat dissipation.

Do not mount VFD in direct sunlight or near other heat sources.

Do not block cooling vents or airflow with any panel components or wires.

See minimum mounting clearance table below for different VFD frame sizes.

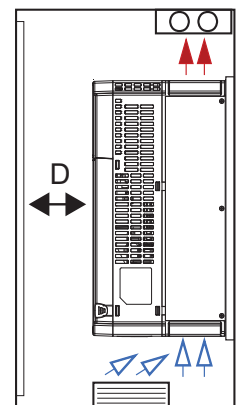
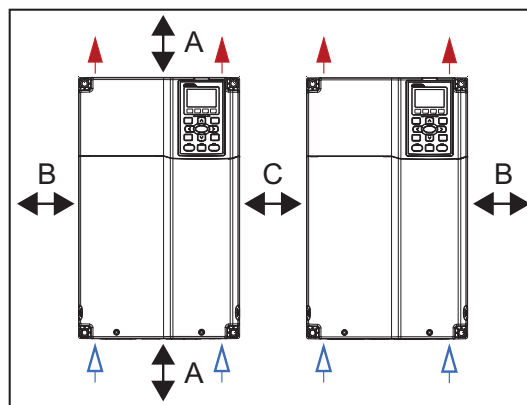

Frame Size	A	B	C	D
A, B, & C	60 mm/2.4 in.	30 mm/1.2 in.	10 mm/0.4 in.	12 mm/0.5 in.
D, E, & F	100 mm/3.9 in.	50 mm/2.0 in.	10 mm/0.4 in.	25 mm/1.0 in.
G	200 mm/7.9 in.	100 mm/3.9 in.	10 mm/0.4 in.	25 mm/1.0 in.
H	350 mm/13.8 in.	150 mm/6.0 in.	10 mm/0.4 in.	50 mm/2.0 in.

Mounting the Drive

⚠ CAUTION

Risk of bodily injury or damage to drive or other equipment.

- The drive should be mounted on a structure such as a wall or post capable of supporting the weight of the unit.
- Ensure suitable mounting hardware is used when installing back plate and drive on drywall
- Use suitable lifting equipment, in good condition, rated for at least 5 times the weight of the drive.
- The drive must be mounted on a heat-resistant back plate.

The mounting location should have nearby access to the electrical supply and to the motor wiring.

Use lag screws or bolts appropriate for supporting the weight of the drive.

1. Mount the drive using the mounting holes on the back side of the enclosure.
2. Screws at the top must attach to a solid structure such as a stud or brace.
3. All screw hole locations should be used to ensure the drive is securely mounted.

IMPORTANT: Do not drill holes in the drive.

Electrical Installation

Wiring Guidelines

⚠ WARNING



Contact with hazardous voltage could result in death or serious injury.

- Disconnect and lock out all power before installing or servicing equipment.
- Always check if DC bus charge LED is off and DC voltage on the terminals DC (+1) and DC (-) is less than 30 VDC before working on VFD wiring. The DC bus capacitors may hold high-voltage charge for several minutes after the VFD power is disconnected.
- Connect the motor, the drive, metal plumbing, and all other metal near the motor or cable to the power supply ground terminal using wire no smaller than motor cable wires.
- All wiring must comply with the National Electrical Code and local codes.

NOTICE

Risk of damage to VFD, or malfunction can occur.

Follow all wire routing and grounding instructions carefully. Inductive currents caused by parallel wiring, or close proximity between high voltage and control wiring can cause unexpected behaviors.

- Do not run input power and motor wires in the same conduit.
- Do not run motor wires from multiple VFDs in common conduit.
- Do not run control wiring parallel with high voltage wiring.
- Do not run VFD wiring parallel with building or facility wiring.
- Do not install power factor correction capacitors, surge suppressors, or RFI filters to the VFD output.
- The use of any disconnecting device (contactor, disconnect etc.) in motor circuit during VFD run can cause damage to VFD power components. Stop VFD before opening the motor circuit with disconnect or contactor.
- Do not use aluminum wires for VFD connections.
- Do not leave wire fragments, metal shavings or other metal objects inside the VFD.
- Improper splicing or damage to motor cable insulation may expose the conductor(s) to moisture and can produce tripping on faults or VFD damage.
- For retrofit application, check the integrity of power and motor leads. This requires measuring the insulation resistance with a suitable megohm-meter.

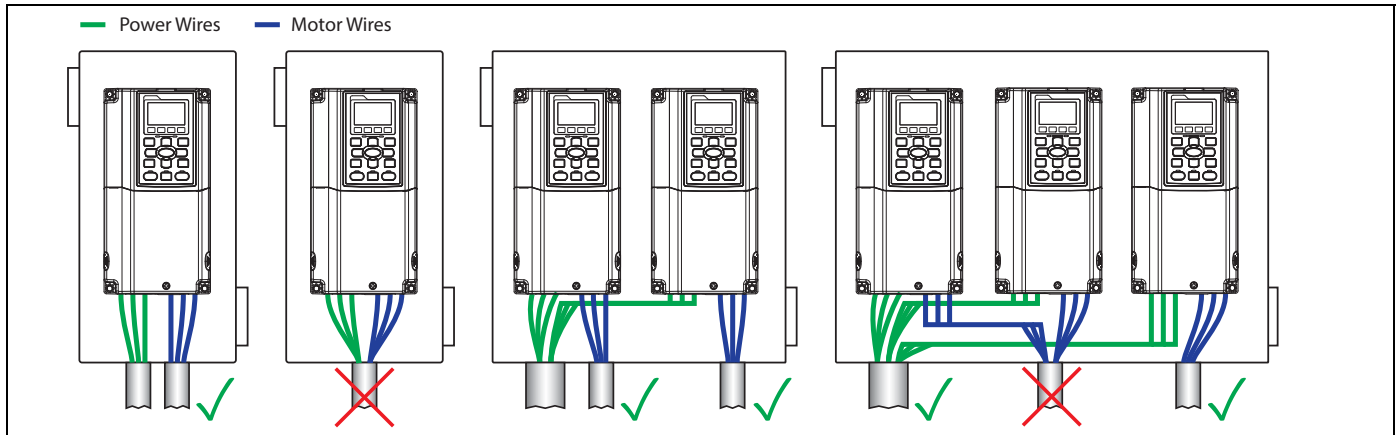

1. Mount the drive as close as possible to the service entrance panel. Connect directly to the service entrance, not to a sub-panel.
2. Use a dedicated branch circuit for the drive. Verify that the circuit is equipped with a properly-sized circuit breaker or fuse.
3. Separate input power and motor wiring by at least 8 in. (20.3 cm).
4. Cross over other branch circuits and facility wiring at a 90° angle. If necessary to run wires in parallel, separate by at least 8 in. (20.3 cm).
5. All control wiring—sensors, switches, transducers, etc.—should be in a separate conduit routed individually, not parallel, from high voltage wiring. In addition, any shielded cables should be properly grounded.
6. Treat Open-Delta power configuration (two-transformer utility bank) as single-phase power and size wiring accordingly.
7. Install a line reactor for VFDs in pump systems with dedicated service transformer to protect VFD from transient power surges and provide some degree of harmonics distortion mitigation. DC Chokes are included in VFDs rated above 50 HP, which will not need line reactors.

Branch Circuit Protection

Integral solid-state short circuit protection does not provide branch circuit protection. Branch Circuit Protection must be provided in accordance with the National Electrical Code (NEC) and applicable local codes; or equivalent as determined by Authorities Having Jurisdiction (AHJ). The Drive shall be protected by Listed Class J fuses or Listed inverse-time circuit breakers only.

Short-circuit current rating (SCCR): The drive is suitable for use on a circuit capable of delivering not more than 100,000 symmetrical amperes (rms) when protected by suitable Class J fuses. Rated fuse current shall be maximum 3 times the motor output full-load current (FLA) rating. Rated circuit breaker current shall be maximum 2.5 times the motor output FLA rating when using single phase or polyphase AC motors. For all other motors, refer to NEC Sec 430 and the Franklin Electric Aim Manual. When protected by a circuit breaker and placed in a panel, drive SCCR is as follows:

VFD Output Rating	Test Current
Up to 50 HP (0 to 37.3 kW)	5,000 Amperes (rms)
51 to 200 HP (39 to 149 kW)	10,000 Amperes (rms)
201 to 400 HP (150 to 298 kW)	18,000 Amperes (rms)
401 to 600 HP (299 to 447 kW)	30,000 Amperes (rms)
601 to 900 HP (448 to 671 kW)	42,000 Amperes (rms)

Wire Sizing

Size power wire to maintain a voltage drop less than 2% at VFD or motor terminals. For submersible pumping applications, refer to the Franklin Electric AIM Manual for wire gauge and distance information.

Frame A: Use only copper conductors rated for at least 75 °C and 600 V. Use cable with a 90 °C rating if ambient environment is greater than 50 °C.

Frame B and above: Use only copper conductors rated for at least 75 °C and 600 V. Use cable with a 90 °C rating if ambient environment is greater than 40 °C (30 °C for models CX-061A-2V, CX-105A-2V, CX-370A-4V, or CX-930A-4V).

Install a load (output) reactor to protect motor windings if distance from VFD to a motor is in the range 45-100 feet. Install output dV/dt filter for a range 100-1000 feet (800 feet for submersible pumps) or a sine wave filter for greater distances.

Power Wiring Connections

NOTICE

Risk of damage to drive, or malfunction can occur.

- Do not connect input power to VFD output terminals U, V, and W otherwise VFD can be damaged.
- Ensure that the system is properly grounded all the way to the service entrance panel. Improper grounding may result in loss of voltage surge protection and interference filtering.
- Do not connect any wires except dynamic braking resistor to (B1) and (B2) terminals.
- Do not remove the jumper between terminals (+2) and (+1) except for dynamic braking unit or DC link choke, otherwise the VFD can be damaged.
- When using a general GFCI (Ground Fault Circuit Interrupter), select a current sensor with sensitivity of 200mA or above and not less than 0.1-second operation time to avoid nuisance tripping.

Power Wiring Diagram

1. Main Connection, Power
2. VFD
3. Motor
4. Ground Terminals
5. Power input terminals
6. Output to Motor terminals
7. Jumper (optional DC reactor, dynamic brake or DC choke unit)
8. Optional brake resistor terminals

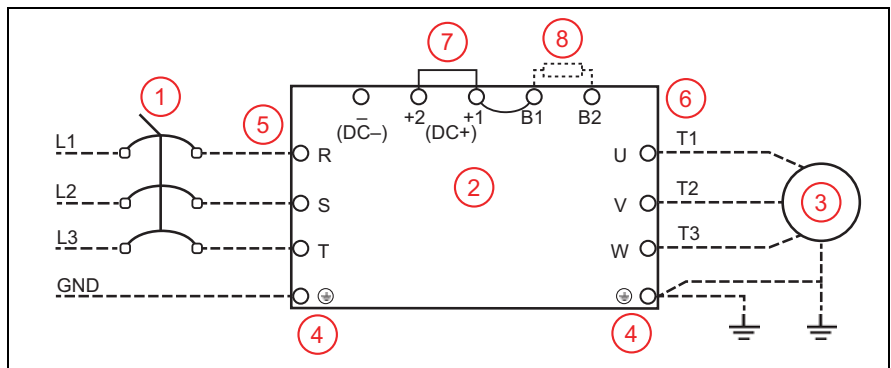

Use ring type terminals for the VFD power wiring.

Power line ground and motor ground wires should be connected to designated ground terminals.

Three-phase power, including Open-Delta must be connected to the R(L1), S(L2), and T(L3) terminals. Proper phase sequencing is not required.

- For single-phase power, connect L1 to R and L2 to S terminals.
- G and H frame VFDs have double-pole power terminals or lugs to accommodate two smaller gauge wires.

Connect three-phase motor wires to the U(T1), V(T2), and W(T3) terminals. When in forward rotation, the motor shaft should turn clockwise when viewed from the motor to the load. If rotation is not correct, reverse any two motor leads.

Frame A: Power terminals accept wire sizes up to 8 AWG and should be tightened to a torque of 17.4 in-lbs (1.96 Nm).

Frame B: Power terminals accept wire sizes up to 4 AWG and should be tightened to a torque of 30.4 in-lbs (3.43 Nm).

Frame C: Power terminals accept wire sizes up to 1/0 AWG and should be tightened to a torque of 69.4 in-lbs (7.84 Nm).

Frame D0: Power terminals accept wire sizes up to 2/0 AWG and should be tightened to a torque of 69.4 in-lbs (7.84 Nm).

Frame D: Power terminals accept wire sizes up to 300 MCM or 4/0 AWG and should be tightened to a torque of 156 in-lbs (18 Nm).

Frame E: Power terminals accept wire sizes up to 4/0 AWG*2 and should be tightened to a torque of 174 in-lbs (20 Nm).

Frame F: Power terminals accept wire sizes up to 300 MCM*2 or 4/0 AWG*2 and should be tightened to a torque of 156 in-lbs (18 Nm).

Frame G: Terminals R, S & T accept wire sizes up to 250 MCM*4 and should be tightened to a torque of 156 in-lbs (18 Nm). Terminals U, V, & T accept wire sizes up to 500 MCM*2 and should be tightened to a torque of 354 in-lbs (40 Nm).

Frame H: Power terminals accept wire sizes up to 350 MCM*4 and should be tightened to a torque of 156 in-lbs (18 Nm).

Control Circuit Connections

Terminal Identification

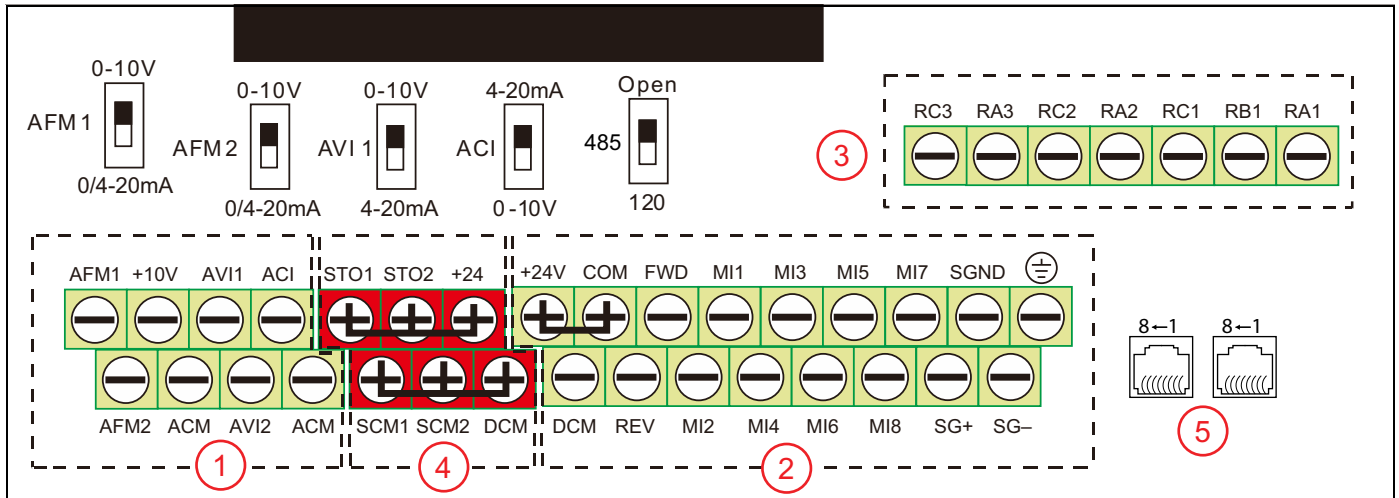

The control board is divided into 5 groups of terminals and connectors, plus a group of micro switches for individual terminal configurations.

- Always insulate bare control or shield wires with shrink tubing or electrical tape to prevent short circuit.
 - The ideal length of stripped wire for control terminals is 5 mm (0.2 in).
1. **Analog Inputs/Outputs** – These connections are used for transducers, sensors, and control systems such as a BAS, BMS, or PLC. Use shielded cable with shield connected to the ground \perp terminal. Terminals accept 26-16 AWG (0.13-1.3mm²) wires, and should be tightened to a torque of 1.73 lb-in (0.19 Nm).
 - **ACI** is a 0-10 VDC or 4-20 mA input, adjustable by micro switch. Set [I0-00] to match the switch setting.
 - **AVI1** is a 0-10 VDC or 4-20 mA input, adjustable by micro switch. Set [I0-05] to match the switch setting.
 - **AVI2** is a 0-10VDC input.

When an input source has been connected, select the appropriate terminal in either **Auto Speed Ref** [SET-07], **Hand Speed Ref** [SET-09], or **PID F/B Source** [SET-18].

 - **AFM1 & AFM2** are programmable, multi-function analog outputs. Refer to [I0-59] and [I0-61] for options. Each output can be set by micro switch to 0-10V (min load 5k Ω at 2 mA) or 0/4-20 mA (max load 500 Ω).
 - **+10V** terminal (with common ACM) provides a +10 VDC 50 mA power supply for input devices.
 - **ACM** terminals are the common for analog inputs, outputs and +10 VDC power supply. All ACM terminals are connected internally.
 2. **Digital Inputs & RS-485 Communication** – These connections provide input for a wide selection of switches or programmable controls. Use shielded cable or twisted wires and separate from the power and motor wiring and other high voltage circuits. Terminals accept wire sizes from 24-14 AWG (0.2-1.5mm²), and should be tightened to a torque of 6.9 lb-in (0.78 Nm).

NOTES:

- Digital inputs are configured for NPN (Sink) mode by default, with a jumper across +24 and COM terminals.
- All digital inputs can be re-programmed from Normally Open to Normally Closed. Refer to [I0-46].
- Digital inputs are activated by voltage 11 VDC or greater with an external power supply. Maximum input voltage rating is 27 VDC at 3.5 mA.
- **MI1-MI8** are programmable, multi-function digital inputs that can be used for a variety of switching features with common terminal DCM. Refer to [I0-21] through [I0-28] for options.
- **FWD & REV** are dedicated Forward and Reverse run commands. If any other digital input is programmed for FWD or REV, corresponding dedicated FWD or REV input will be disabled automatically.

ELECTRICAL INSTALLATION

Control Circuit Connections

- **SG+, SG-, & SGND** are communication terminals for Modbus RS485 with a shielded cable. Termination resistance is controlled by micro switch. Set the switch to the **Down** position to connect 120 Ω termination resistance for long distance or for an electrically noisy environment.
- **+24** terminal provides 24 VDC (with DCM common) 50 mA power for digital control circuits and 150 mA for external transducers.
- **COM** terminal is a digital inputs common. By default, it is connected by jumper to +24 to configure NPN (Sink) mode.
- **DCM** is the internal 24 VDC power supply common.
- \perp Earth ground. Use this terminal to connect shield wires.

IMPORTANT: DCM and ACM terminals are isolated from each other and from the ground. Do not connect these terminals to earth ground, which can cause electrical noise in control circuits and unstable VFD operation.

3. **Relay Outputs** – These are configurable, multi-function, dry contact relays. Refer to [I0-47] through [I0-49] for options. Terminals accept wire sizes from 24-14 AWG (0.2-1.5mm²), and should be tightened to a torque of 4.3 lb-in (0.49 Nm).
 - Relays ratings are 1.25A at 250 VAC, or 3A at 30 VDC.
 - RA1-RB1-RC1 is a single-pole, double throw relay. RA1-RC1 is N.O. (normally open), and RB1-RC1 is N.C. (normally closed).
 - RA2-RC2 and RA3-RC3 are independent single pole, single throw, normally open relays.
4. **Safety Off Inputs** – These connections provide emergency stop control from an external system. By default, the inputs are closed through jumper wires, allowing the drive to run.
5. **RJ-45 Sockets** – These connections are communication terminals for PLC, Modbus, or BACnet. Use [PLC-23] to set the Com Type. Then set both Speed Reference and Run Command to **RS485**. Both RJ-45 sockets are connected internally.

Example Configurations

4-20mA Speed Control Signal from an External BAS, BMS or PLC:

- Connect the BMS or PLC output signal to the ACI or AVI1 terminal. The ACI micro switch should be in the **UP** position. If using the AVI1 terminal, the AVI1 micro switch should be **DOWN**.
- Connect the BMS Com wire to the ACM terminal (signal ground).
- Any shield wire should be connected to \perp Earth ground.
- **ACI Input Select [I0-00]** or **AVI1 Input Select [I0-05]** should be set to the correct signal type.
- **Auto Speed Reference [SET-07]** should be set to the chosen input.

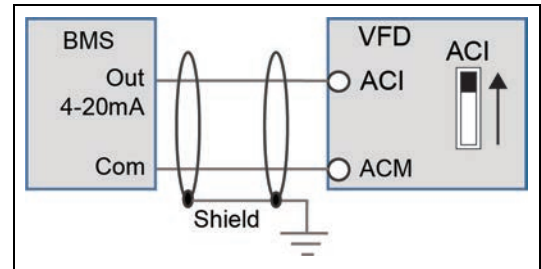

0-10V Speed Control Signal from an External BAS, BMS or PLC:

- Connect the BMS or PLC output signal to the AVI1, AVI2, or ACI terminal. The AVI1 micro switch should be in the **UP** position. If using the ACI terminal, the ACI micro switch should be **DOWN**.
- Connect the BMS Com wire to the ACM terminal (signal ground).
- Any shield wire should be connected to \perp Earth ground.
- **AVI1 Input Select [I0-05]** or **ACI Input Select [I0-00]** should be set to 0-10V.
- **Auto Speed Reference [SET-07]** should be set to the chosen input.

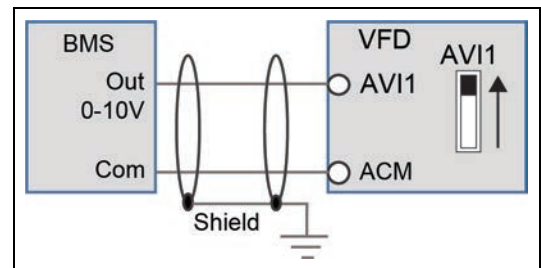

4-20mA Transducer with VFD 10 VDC Power:

- Connect the transducer positive (Ppower) wire to the VFD +10V terminal.
- Connect the transducer output (Out) wire to the ACI or AVI1 terminal. The ACI micro switch should be in the **UP** position. If using the AVI1 terminal, the AVI1 micro switch should be **DOWN**.
- Any shield wire should be connected to \perp Earth ground.
- **ACI Input Select [I0-00]** or **AVI1 Input Select [I0-05]** should be set to the correct signal type.
- **Auto Speed Reference [SET-07]** should be set to **PID Output**, **PID Feedback Source [SET-18]** should be set to the chosen input, and **PID Feedback Units [SET-19]** should be set to the appropriate scale (psi, temp, flow, etc.).

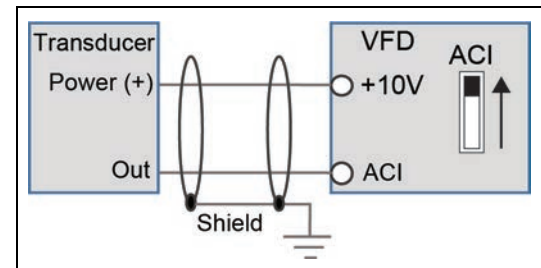

4-20mA Transducer with VFD 24 VDC Power:

- Connect the transducer positive (Power) wire to the VFD +24V terminal.
- Connect the transducer output (Out) wire to the ACI or AVI1 terminal. The ACI micro switch should be in the **UP** position. If using the AVI1 terminal, the AVI1 micro switch should be **DOWN**.
- Use a jumper wire to connect the ACM and DCM terminals.
- Any shield wire should be connected to \perp Earth ground.
- **ACI Input Select [10-00]** or **AVI1 Input Select [10-05]** should be set to the correct signal type.
- **Auto Speed Reference [SET-07]** should be set to **PID Output**, **PID Feedback Source [SET-18]** should be set to the chosen input, and **PID Feedback Units [SET-19]** should be set to the appropriate scale (psi, temp, flow, etc.).

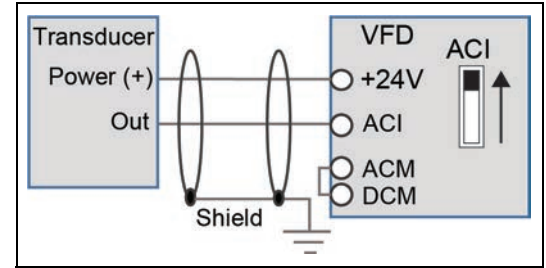

4-20mA Transducer with External 24 VDC Power:

- Connect the transducer positive (Power) wire to the external source positive [+24V]. Connect the external source negative to the VFD ACM terminal.
- Connect the transducer output (Out) wire to the ACI or AVI1 terminal. The ACI micro switch should be in the **UP** position. If using the AVI1 terminal, the AVI1 micro switch should be **DOWN**.
- Any shield wire should be connected to \perp Earth ground.
- **ACI Input Select [10-00]** or **AVI1 Input Select [10-05]** should be set to the correct signal type.
- **Auto Speed Reference [SET-07]** should be set to **PID Output**, **PID Feedback Source [SET-18]** should be set to the chosen input, and **PID Feedback Units [SET-19]** should be set to the appropriate scale (psi, temp, flow, etc.).

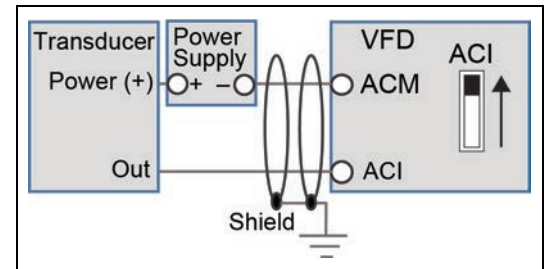

0-10VDC Transducer with VFD 10 VDC Power:

- Connect the transducer positive (Power) wire to the VFD +10V terminal.
- Connect the transducer output (Out) wire to the AVI1, AVI2, or ACI terminal. The AVI1 micro switch should be in the **UP** position. If using the ACI terminal, the ACI micro switch should be **DOWN**.
- Connect the transducer Com wire to the ACM terminal (signal ground).
- Any shield wire should be connected to \perp Earth ground.
- **AVI1 Input Select [10-05]** or **ACI Input Select [10-00]** should be set to **0-10V**.
- **Auto Speed Reference [SET-07]** should be set to **PID Output**, **PID Feedback Source [SET-18]** should be set to the chosen input, and **PID Feedback Units [SET-19]** should be set to the appropriate scale (psi, temp, flow, etc.).

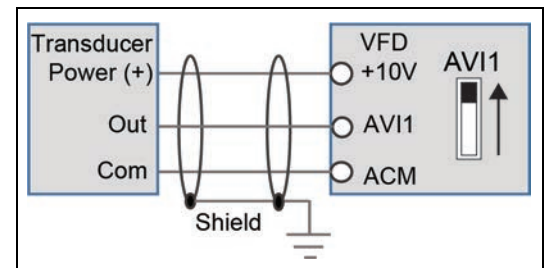

0-10VDC Transducer with VFD 24 VDC Power:

- Connect the transducer positive (Power) wire to the VFD +24V terminal.
- Connect the transducer output (Out) wire to the AVI1, AVI2, or ACI terminal. The AVI1 micro switch should be in the **UP** position. If using the ACI terminal, the ACI micro switch should be **DOWN**.
- Connect the transducer Com wire to the ACM terminal (signal ground).
- Use a jumper wire to connect the ACM and DCM terminals.
- Any shield wire should be connected to \perp Earth ground.
- **AVI1 Input Select [10-05]** or **ACI Input Select [10-00]** should be set to **0-10V**.
- **Auto Speed Reference [SET-07]** should be set to **PID Output**, **PID Feedback Source [SET-18]** should be set to the chosen input, and **PID Feedback Units [SET-19]** should be set to the appropriate scale (psi, temp, flow, etc.).

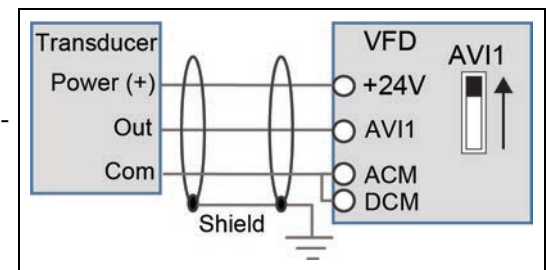

ELECTRICAL INSTALLATION

Control Circuit Connections

0-10VDC Transducer with External 24 VDC Power:

- Connect the transducer positive (Power) wire to the external source positive [+24V].
- Connect the transducer Com wire to the external source negative.
- Connect the transducer output (Out) wire to the AVI1, AVI2, or ACI terminal. The AVI1 micro switch should be in the **UP** position. If using the ACI terminal, the ACI micro switch should be **DOWN**.
- Any shield wire should be connected to \perp Earth ground.
- **AVI1 Input Select [I0-05]** or **ACI Input Select [I0-00]** should be set to 0-10V.
- **Auto Speed Reference [SET-07]** should be set to **PID Output**, **PID Feedback Source [SET-18]** should be set to the chosen input, and **PID Feedback Units [SET-19]** should be set to the appropriate scale (psi, temp, flow, etc.).

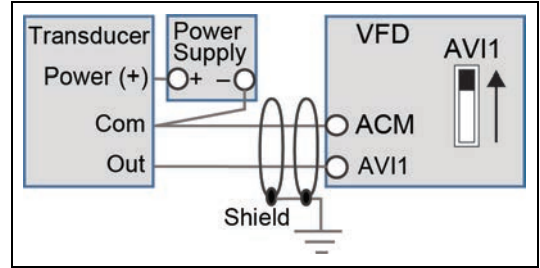

Temperature Protection or PID Control with PT-100 or PTC Sensor:

- Connect the sensor Positive wire to the AFM2 terminal. Place the AFM2 micro switch in the **DOWN** position.
- Connect the sensor Negative wire to the ACM terminal.
- Use a jumper wire to connect the AFM2 and AVI1 terminals. The AVI1 micro switch should be in the **UP** position.
- Any shield wire should be connected to \perp Earth ground.
- **AFM2 Out Select [I0-61]** should be set to Output Voltage.
- **AVI1 Input Select [I0-05]** should be set to **PT100** or **PTC**.
- For PID control, **Auto Speed Reference [SET-07]** should be set to **PID Output**, **PID Feedback Source [SET-18]** should be set to the chosen input, and **PID Feedback Units [SET-19]** should be set to the appropriate scale (psi, temp, flow, etc.).
- For temperature protection, make appropriate settings to **[PROT-30-33]**.

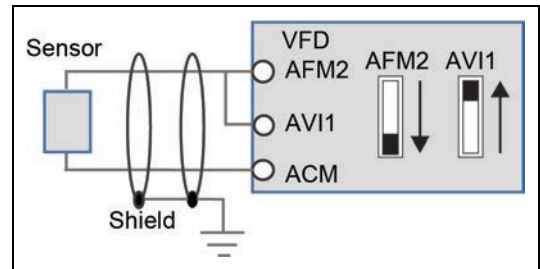

Speed Control using 0-10 VDC Potentiometer:

- Connect the potentiometer Positive wire to the VFD +10V terminal.
- Connect the potentiometer Output wire to the AVI1, AVI2, or ACI terminal. The AVI1 micro switch should be in the **UP** position. If using the ACI terminal, the ACI micro switch should be **DOWN**.
- Connect the potentiometer Com wire to the ACM terminal (signal ground).
- Any shield wire should be connected to \perp Earth ground.
- **AVI1 Input Select [I0-05]** or **ACI Input Select [I0-00]** should be set to 0-10V.
- **Auto Speed Reference [SET-07]** or **Hand Speed Reference [SET-09]** should be set to the chosen input.

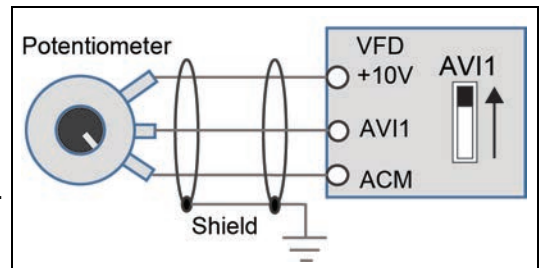

Drive Configuration

Using the Control Interface

LCD Display Screen

Function Keys provide access to (F1) Jog Function, (F2) View Mode, and (F3) Fault history.

The **HAND** LED indicates when the VFD is in Hand mode.

The **Back** key returns display to the previous screen.

Left and Right Arrow keys allow navigation between parameter groups, and also cursor movement when setting a value.

The **HAND** key places the VFD in Hand mode when keypad control is enabled.

The **START** key starts the motor when keypad control is enabled. The LED indicates that a Start command is present.

The **FWD/REV** key selects motor direction when enabled. The LED lights either green or red to indicate selection.

The **ESC** key returns to the Home Screen from any menu.

The **RUN** LED indicates that power is being sent to the motor.

Up and Down Arrow keys allow navigation within a parameter group.

The **MENU** key provides access for editing all parameter groups.

The **ENTER** key places the VFD in programming mode and confirms changes to parameters.

The **AUTO** key places the VFD in Auto mode when keypad control is enabled.

The **STOP/RESET** key stops the motor when keypad control is enabled, or if enabled in remote mode. The LED indicates that the VFD is stopped.

Home Screen Display Options

1. Operating Status

Run/Stop
Limit by PID 2
Ctrl by PID 2
Stopped by AI
Backspin Timer
Lubrication
Limit by Level
Limit by Temp
Stall

2. Command Source

K = Keypad
T = Terminal control
R = RS485
O = Option board

3. Frequency Source

K = Keypad/PID
V1 = from AV1
V2 = from AV2
C = from ACI
R = RS485
O = Option board
1-15 = Step speed
J = Jog frequency

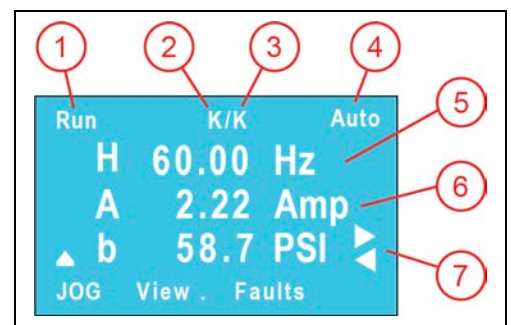

4. Mode = Hand or Auto

5. User selectable display.

Use Arrow and Enter keys to step through selections and to change setpoints.

H = Output speed when running (Hz).

P = PID Setpoint in application based units (PSI, inWC, etc.) [SET-21]. This is adjustable using the keypad.

F = Keypad Setpoint (Hz). This is adjustable using the keypad.

6. Output Current.

Other options available through [VFD-48].

7. User selectable display.

Use Arrow keys to step through choices. This display corresponds to choices in [SET-57].

DRIVE CONFIGURATION

Enter Required Parameters Before Starting VFD

Enter Required Parameters Before Starting VFD

1. **Application [SET-00]:** Use the keypad to select the type of application the drive will control. When a selection has been made, application related parameters will be automatically updated to proper defaults. Enter the following parameters to ensure best performance for the specific installation.
NOTE: the **BASIC** application provides standard VFD control with start/stop command from keypad and speed reference from a remote analog signal. For systems using a transducer or other control sensors, choose the relevant motor type to ensure that correct defaults are set.
2. **Input Power Phase [SET-01]:** Verify that the setting matches the type of power supply—either 3-phase (default) or 1-phase. Changing to 1-phase requires derating of the maximum FLA [SET-03]. Drives that do not include a DC Link Reactor are limited to 50% of the drive's rated current. Drives that include a DC Link Reactor only output 33% of the 3-phase output current.
3. **Motor Horsepower [SET-02]:** Enter the rated horsepower from the motor nameplate.
4. **Motor FLA (SFA) [SET-03]:** Enter the FLA (Full Load Amps) rating from the motor nameplate; or, enter SFA (Service Factor Amps) if using a submersible pump motor.
5. **Motor RPM [SET-04]:** Enter the rated motor RPM from the motor nameplate.
6. **Motor Voltage [SET-05]:** Enter the rated voltage from the motor nameplate.

Verify Default Settings

After the initial parameters have been entered, the following default settings should be checked and adjusted to ensure expected operation. Refer to the [“Default Settings Tables” on page 13](#) for a list of automatically populated settings per application.

1. **Auto Speed Ref [SET-07]:** Select the source of frequency (speed) setpoint the drive will use when in Auto mode.
 - When using one of the analog inputs with an automated BAS, BMS, or PLC system, be sure to configure the terminal for the correct impedance. Refer to [“Terminal Identification” on page 5](#).
 - When using feedback from an analog sensor, such as a transducer, select PID Output. When PID mode is selected, additional parameters must be verified for setpoints, inputs, and limits.
2. **Auto Run Command [SET-08]:** Select the source of RUN command when VFD is in Auto Mode—Keypad or external.
3. **Hand Speed Ref [SET-09]:** Select the source of frequency (speed) setpoint the drive will use when in Hand mode. PID is disabled in Hand mode. Be sure to configure any selected input terminals for the correct impedance.
4. **Hand Run Command [SET-10]:** Select the source of RUN command when VFD is in Hand Mode—Keypad or external.
5. **Low Frequency Limit [SET-13]:** The lowest frequency (speed in Hz) allowed by the VFD in any mode.
6. **High Frequency Limit [SET-14]:** Enter the highest frequency (speed in Hz) allowed by the VFD in any mode.
7. **PID Mode [SET-17]:** Enables or disables PID control, either direct or inverse.
8. **PID Feedback Source [SET-18]:** Selects an input terminal for PID Feedback source. Be sure to configure the terminal for the correct impedance.
9. **PID Feedback Unit [SET-19]:** Selects a measurement unit for PID feedback.
10. **Feedback Max [SET-20]:** Enter the maximum reading of the feedback source. This is used to scale the sensor.
11. **PID Setpoint [SET-21]:** Enter the desired value for the drive to maintain in PID mode, running in Auto. This parameter can also be changed through keypad control.
12. **PID Low Frequency Limit [SET-22]:** PID frequency output will be limited to this value.
13. **PID High Frequency Limit [SET-23]:** PID frequency output will be limited to this value.

Enter or Verify Optional Settings

There are many optional features available for customizing system operation. Some examples are included in [“Operation” on page 11](#). For more information, refer to the Cerus X-Drive Installation and Operation Manual as follows:

- **Automation features**
- **Protection features**
- **Maintenance features**
- **Communications features**
- **Multi-Drive/Motor applications**

Operation

Basic Operation

The drive can be operated in either **HAND** or **AUTO** mode as follows:

- **HOA Mode Source [SET-60]:** This setting selects whether Hand/Auto control will come from the Keypad, a Digital Input, or Communications.
- **HAND mode** runs the motor based on **Hand Speed Ref [SET-09]** (frequency source) and **Hand Run Cmd [SET-10]** (command source). Defaults for both settings are Keypad, which runs the motor at a fixed speed (**Keypad Setpoint**) set on the Home Screen. Both settings can be reprogrammed for external control. PID control is disabled in Hand mode.
- **AUTO mode** runs the motor based on **AUTO Speed Ref [SET-07]** (frequency source) and **AUTO Run Cmd [SET-08]** (command source). The speed reference default is set per application. The run command default is Keypad. Both settings can be reprogrammed as required.

Standard Operation with an Automated Control System (Fan and Pump Applications)

In many VFD applications, including ventilation, water supply, or irrigation, motor speed is often determined by an automated system such as a BAS, BMS, or PLC. These systems provide control information to the VFD either through a communications protocol such as Modbus or BACnet, or through direct electrical connection to one of the analog input terminals.

When the drive is in **AUTO** mode, it runs the motor at a variable frequency based on information from the automation system through the input selected in **Auto Speed Ref [SET-07]**.

Standard Operation with PID Feedback Control (all Applications)

A PID controlled application, such as a fan system or a constant pressure pump system, uses feedback from a transducer to measure system performance against a user defined Setpoint (target) to control motor speed. The VFD can use several types of measurement, including pressure, flow, level, temperature, etc.

For example:

- In a pumping application, the default measurement unit is **PSI**. As user demand (flow) causes pressure changes, the drive varies the output frequency (motor speed) to maintain pressure at the target setpoint. When the drive determines a no-demand condition, it enters Sleep mode and stops the motor.
- In a fan application, the default measurement unit is **inWC** (air pressure).

When the drive is in **AUTO** mode, it runs the motor at a variable frequency based on a comparison between the **PID Setpoint [SET-21]** and feedback from the PID transducer, up to the **PID Hi Hz Limit [SET-23]**. PID operation is disabled in **HAND** mode.

When basic setup is complete, including motor specifications, verify or set the following parameters for PID operation:

Auto Speed Ref [SET-07]: This should be set to **PID Output**.

Auto Run Command [SET-08]: Select source of Run Command, either Keypad or external. If using a Digital Input (M1-8) with a switch, set the terminal to **FWD** (or **REV**) [10-21 ~ 28].

PID Mode [SET-17]: Set to **PID Direct** for most PID operations (exceptions are noted in the tables).

Feedback Source [SET-18]: Set to the terminal used for transducer connection. Make sure impedance is set correctly.

PID Feedback Units [SET-19]: Set to the appropriate measurement unit for the transducer type.

PID Feedback Max [SET-20]: Set to the maximum rating of the transducer.

PID Keypad Setpoint [SET-21]: Set to the desired measurement target.

Sleep Mode [SET-26]: This should be enabled for most pump applications, and **Disabled** for most HVAC applications.

Sleep Mode with Pressure Boost (Pump Applications)

The Sleep feature monitors pressure and frequency to detect a no-demand condition, at which point it stops the motor. The Sleep Feature also has the option to boost system pressure by a set amount before stopping.

The Sleep feature works only in Auto mode using PID Direct (Sleep is disabled when PID mode is set to Inverse). PID2 operation does not have Sleep function.

OPERATION

Damper Control (HVAC Applications)

The following parameters control Sleep functions:

Sleep Mode [SET-26]: This setting disables or enables sleep mode or the sleep plus boost option. The default value for submersibles and surface/boost pump applications is **Sleep Only**. If a pressure boost is desired while the system is at rest, select **Sleep + Boost** and set a **Sleep Boost Value [SET-29]**.

Sleep Check Time [SET-27]: Time delay (sleep check cycle time) before each Sleep Check procedure. Default = 10 sec.

Sleep Delay [SET-28]: Delay before VFD triggers Sleep Mode when all other conditions are met. Default = 6 sec.

Sleep Boost Value [SET-29]: Value added to original setpoint to provide pressure boost—0.0 to 10.0% of Feedback Max Value [SET-20]. Default = 3%.

Sleep-Boost Timer [SET-30]: Timer that limits sleep boost duration if Sleep Boost setpoint is not reached—5 to 120 seconds. Default = 10 sec.

Wakeup Level [SET-31]: Sets a wakeup level for VFD to quit Sleep mode and start running—0.0 to [SET-21]. Default = 55 PSI.

Sleep Bump Timer [SET-32]: Sets a duration time for pressure bump to increase system pressure as part of the no-demand calculation. Default = 5 sec.

All default settings related to Sleep mode have been calculated for best system performance for most applications. However, some well conditions may require a slight adjustment.

During system setup it is recommended to test the Sleep feature by closing a main valve to simulate a no-demand condition. The system should be running at normal demand, maintaining pressure setpoint, then flow should be decreased slowly until stopped.

- If the system does not enter Sleep mode, it may be necessary to increase the **PID Lo Hz Limit [SET-22]** to ensure that system pressure reaches **PID Setpoint [SET-21]** (plus boost, if enabled).
- If, during normal operation, the system enters Sleep mode, but cycles on and off rapidly as it nears the Setpoint, it may be necessary to slightly lower the **PID Lo Hz Limit [SET-22]** to prevent Sleep mode problems.

Damper Control (HVAC Applications)

The VFD can provide a relay output to open a damper actuator before starting a fan motor. When enabled, the damper relay output is activated when the system receives a **RUN** command and the motor will start based on the following configurations:

- **With Damper Limit Switch:** If any Digital Input [10-21 through 28] is set to **Damper Limit Sw** and the VFD receives a **RUN** command, the damper relay is activated and when the damper limit switch is closed (damper is fully open and DI is activated), the VFD will start the motor.

If the limit switch is not closed within the **Damper Time Delay [10-37]**, the VFD will trip on Damper Fault. If at any point during run mode damper limit switch is open for more than 2 seconds, the VFD will trip on Damper Fault. VFD will try to restart based on retry number setting [PROT-10].

- **Without Damper Limit Switch.** If no Digital Input is configured for a damper limit switch and the VFD receives a **RUN** command, the damper relay is activated and when **Damper Time Delay [10-37]** is complete, the VFD will start the motor. There is no damper fault detection because there is no damper limit switch feedback.

NOTE: If any other delay timer is set and the VFD receives a **RUN** command, the damper relay will start after the first timer expires.

During run mode the damper relay stays activated. When a **STOP** command is received, the damper relay will be deactivated only in VFD stop state. If stop mode is set to deceleration, the relay will be deactivated after VFD reaches zero speed (0.00Hz).

Set the following parameters to use the Damper Control function:

Damper Mode [10-36]: This setting enables or disables damper mode.

Damper T-Delay [10-37]: This setting provides a run time delay without a damper limit switch; or, provides a Damper Fault delay for systems that include a damper limit switch. The delay time should be greater than damper opening time.

Damper Output Terminal [10-47 through 49]: Connect the damper actuator to one of the Relay Outputs (RA1-3), and set the corresponding parameter to **38 Damper Output**.

Damper Limit SW Terminal [10-21 through 28]: If the system includes a damper limit switch, connect the switch to one of the Digital Inputs (MI1-8) and set the corresponding parameter to **34 Damper Limit SW**.

Default Settings Tables

Set Menu

Parameters in highlighted rows are reset when the application is changed [SET-00].

CODE	Display	Basic	Supply Fan	Exhaust Fan	Cooling Tower	Centrifugal Pump	Submersible Pump	Vacuum Pump	Constant Torque	PM Motor	PM Submersible
SET-01	Input Phase	3-Phase	3-Phase	3-Phase	3-Phase	3-Phase	3-Phase	3-Phase	3-Phase	3-Phase	3-Phase
SET-02	Motor HP	By VFD Rating	By VFD Rating	By VFD Rating	By VFD Rating	By VFD Rating	By VFD Rating	By VFD Rating	By VFD Rating	By VFD Rating	By VFD Rating
SET-03	Motor FLA (SFA)	By VFD Rating	By VFD Rating	By VFD Rating	By VFD Rating	By VFD Rating	By VFD Rating	By VFD Rating	By VFD Rating	By VFD Rating	By VFD Rating
SET-04	Motor RPM	1750	1750	1750	1750	1750	3450	1750	1750	3450	3600
SET-05	Motor Voltage	By VFD Rating	By VFD Rating	By VFD Rating	By VFD Rating	By VFD Rating	By VFD Rating	By VFD Rating	By VFD Rating	By VFD Rating	By VFD Rating
SET-07	Auto Speed Ref	ACI Analog	PID Output	PID Output	PID Output	PID Output	PID Output	PID Output	ACI Analog	ACI Analog	PID Output
SET-08	Auto Run Cmd	Keypad	Keypad	Keypad	Keypad	Keypad	Keypad	Keypad	Keypad	Keypad	Keypad
SET-09	Hand Speed Ref	Keypad	Keypad	Keypad	Keypad	Keypad	Keypad	Keypad	Keypad	Keypad	Keypad
SET-10	Hand Run Cmd	Keypad	Keypad	Keypad	Keypad	Keypad	Keypad	Keypad	Keypad	Keypad	Keypad
SET-11	Accel Time	20 Sec	20 Sec	20 Sec	20 Sec	20 Sec	2 Sec	20 Sec	20 Sec	20 Sec	2 Sec
SET-12	Decel Time	30 Sec	30 Sec	30 Sec	30 Sec	30 Sec	2 Sec	30 Sec	30 Sec	30 Sec	2 Sec
SET-13	Low Freq Limit	20 Hz	20 Hz	20 Hz	20 Hz	20 Hz	30 Hz	20 Hz	0 Hz	40 Hz	60 Hz
SET-14	High Freq Limit	60 Hz	60 Hz	60 Hz	60 Hz	60 Hz	60 Hz	60 Hz	60 Hz	115 Hz	115 Hz
SET-15	Load Rotation	FWD Only	FWD Only	FWD Only	FWD Only	FWD Only	FWD Only	FWD Only	FWD Only	FWD Only	FWD & REV
SET-16	Stop Mode	Coast	Coast	Coast	Coast	Decel	Decel	Coast	Decel	Coast	Coast
SET-17	PID Mode	PID Direct	PID Direct	PID Inverse	PID Inverse	PID Direct	PID Direct	PID Direct	PID Direct	PID Direct	PID Direct
SET-18	PID F/B Source	ACI	ACI	ACI	ACI	ACI	ACI	ACI	ACI	ACI	ACI
SET-19	PID F/B Unit	PSI	inWC	inWC	°F	PSI	PSI	inWC	PSI	inWC	PSI
SET-20	PID F/B Max	1 PSI	1 inWC	1 inWC	150 °F	100 PSI	100 PSI	407 inWC	100 PSI	1 inWC	100 PSI
SET-21	PID Setpoint	0.5 PSI	0.5 inWC	0.5 inWC	76 °F	60 PSI	60 PSI	60 PSI	60 PSI	0.5 inWC	60 PSI
SET-22	PID Lo Hz Limit	20 Hz	20 Hz	20 Hz	20 Hz	20 Hz	30 Hz	20 Hz	20 Hz	40 Hz	60 Hz
SET-23	PID Hi Hz Limit	60 Hz	60 Hz	60 Hz	60 Hz	60 Hz	60 Hz	60 Hz	60 Hz	115 Hz	115 Hz
SET-24	PID P-Gain	1%	1%	1%	1%	2%	2%	1%	1%	1%	20%
SET-25	PID I-Time	1 Sec	1 Sec	1 Sec	1 Sec	1 Sec	1 Sec	1 Sec	0.5 Sec	1 Sec	0.5 Sec
SET-26	Sleep Mode	Disabled	Disabled	Disabled	Disabled	Sleep Only	Sleep Only	Disabled	Disabled	Disabled	Sleep Only
SET-27	Sleep Check Time	10 Sec	10 Sec	10 Sec	10 Sec	10 Sec	10 Sec	10 Sec	10 Sec	10 Sec	10 Sec
SET-28	Sleep Delay Time	6 Sec	6 Sec	6 Sec	6 Sec	6 Sec	6 Sec	6 Sec	6 Sec	6 Sec	6 Sec
SET-29	Sleep Boost Value	3%	3%	3%	3%	3%	3%	3%	3%	3%	3%
SET-30	Sleep Boost Timer	10 Sec	10 Sec	10 Sec	10 Sec	10 Sec	10 Sec	10 Sec	10 Sec	10 Sec	10 Sec
SET-31	Wake-Up Level	0.5 PSI	0.5 inWC	0.5 inWC	75 °F	55 PSI	55 PSI	55 inWC	55 PSI	0.5 inWC	55 PSI
SET-32	Sleep Bump Timer	5 Sec	5 Sec	5 Sec	5 Sec	5 Sec	5 Sec	5 Sec	5 Sec	5 Sec	5 Sec
SET-33	Pipe Fill Timer	0 Min	0 Min	0 Min	0 Min	0 Min	0 Min	0 Min	0 Min	0 Min	0 Min
SET-34	Pipe Fill Exit Level	0.4 PSI	0.4 inWC	0.4 inWC	74 °F	25 PSI	25 PSI	25 inWC	25 PSI	0.4 inWC	25 PSI
SET-35	Pipe Fill Freq	47 Hz	47 Hz	47 Hz	47 Hz	47 Hz	47 Hz	47 Hz	47 Hz	95 Hz	95 Hz
SET-36	Broken Pipe Level	0 PSI	0 inWC	0 inWC	0 °F	15 PSI	15 PSI	0 inWC	0 PSI	0.4 inWC	15 PSI
SET-37	Broken Pipe Freq	59.5 Hz	59.5 Hz	59.5 Hz	59.5 Hz	59.5 Hz	59.5 Hz	59.5 Hz	59.5 Hz	114 Hz	114 Hz
SET-38	Broken Pipe Delay	180 Sec	180 Sec	180 Sec	180 Sec	180 Sec	180 Sec	180 Sec	180 Sec	180 Sec	180 Sec
SET-39	Overpressure Set	Disabled	Disabled	Disabled	Disabled	OP Auto Reset	OP Auto Reset	Disabled	OP Auto Reset	Disabled	OP Auto Reset
SET-40	Overpressure Lvl	1 PSI	1 inWC	1 inWC	80 °F	80 PSI	80 PSI	80 inWC	80 PSI	1 inWC	80 PSI
SET-41	Underload Select	Coast Stop	Coast Stop	Coast Stop	Coast Stop	Coast Stop	Coast Stop	Coast Stop	Coast Stop	Coast Stop	Coast Stop
SET-42	Underload Level	45%	45%	45%	45%	45%	70%	45%	45%	45%	70%
SET-43	Underload Freq	30 Hz	30 Hz	30 Hz	30 Hz	30 Hz	59 Hz	30 Hz	20 Hz	40 Hz	114 Hz
SET-44	Underload Delay	2 Sec	2 Sec	2 Sec	2 Sec	2 Sec	2 Sec	2 Sec	2 Sec	2 Sec	2 Sec
SET-45	ULD Recovery T	0 Min	0 Min	0 Min	0 Min	30 Min	30 Min	0 Min	0 Min	0 Min	30 Min
SET-47	High Load Select	Coast Stop	Coast Stop	Coast Stop	Coast Stop	Coast Stop	Coast Stop	Coast Stop	Coast Stop	Coast Stop	Coast Stop
SET-48	High Load Level	110%	110%	110%	110%	110%	110%	110%	150%	110%	110%
SET-49	High Load Freq	20 Hz	20 Hz	20 Hz	20 Hz	20 Hz	30 Hz	20 Hz	20 Hz	40 Hz	60 Hz
SET-50	High Load Delay	2 Sec	2 Sec	2 Sec	2 Sec	2 Sec	2 Sec	2 Sec	2 Sec	2 Sec	5 Sec
SET-51	HLD Recovery T	0 Min	0 Min	0 Min	0 Min	0 Min	0 Min	0 Min	0 Min	0 Min	0 Min

DEFAULT SETTINGS TABLES

I/O Menu

CODE	Display	Basic	Supply Fan	Exhaust Fan	Cooling Tower	Centrifugal Pump	Submersible Pump	Vacuum Pump	Constant Torque	PM Motor	PM Submersible
SET-52	HLD Recovery Cnt	0 Min	0 Min	0 Min	0 Min	0 Min	0 Min	0 Min	0 Min	0 Min	0 Min
SET-53	ACC Change Freq	0 Hz	0 Hz	0 Hz	0 Hz	0 Hz	0 Hz	0 Hz	0 Hz	0 Hz	60 Hz
SET-54	Second ACC	60 Sec	60 Sec	60 Sec	60 Sec	60 Sec	60 Sec	60 Sec	60 Sec	60 Sec	5 Sec
SET-55	Second DCC	60 Sec	60 Sec	60 Sec	60 Sec	60 Sec	60 Sec	60 Sec	60 Sec	60 Sec	5 Sec
SET-57	User Display	PID Feedback	PID Feedback	PID Feedback	PID Feedback	PID Feedback	PID Feedback	PID Feedback	PID Feedback	PID Feedback	PID Feedback
SET-60	HOA Mode Source	Keypad	Keypad	Keypad	Keypad	Keypad	Keypad	Keypad	Keypad	Keypad	Keypad

I/O Menu

Parameters in highlighted rows are reset when the application is changed [SET-00].

CODE	Display	Basic	Supply Fan	Exhaust Fan	Cooling Tower	Centrifugal Pump	Submersible Pump	Vacuum Pump	Constant Torque	PM Motor	PM Submersible
IO-00	ACI Input Sel	4-20mA	4-20mA	4-20mA	4-20mA	4-20mA	4-20mA	4-20mA	4-20mA	4-20mA	4-20mA
IO-05	AVI1 Input Sel	0-10V	0-10V	0-10V	0-10V	0-10V	0-10V	0-10V	0-10V	0-10V	0-10V
IO-19	Min Freq Limit	40 Hz	40 Hz	40 Hz	40 Hz	40 Hz	40 Hz	40 Hz	40 Hz	80 Hz	80 Hz
IO-21	MI1 Define	Speed-L	Speed-L	Speed-L	Speed-L	Speed-L	Speed-L	Speed-L	Speed-L	Speed-L	Speed-L
IO-22	MI2 Define	Speed-M	Speed-M	Speed-M	Speed-M	Speed-M	Speed-M	Speed-M	Speed-M	Speed-M	Speed-M
IO-23	MI3 Define	Speed-H	Speed-H	Speed-H	Speed-H	Speed-H	Speed-H	Speed-H	Speed-H	Speed-H	Speed-H
IO-24	MI4 Define	Fault Reset	Fault Reset	Fault Reset	Fault Reset	Fault Reset	Fault Reset	Fault Reset	Fault Reset	Fault Reset	Fault Reset
IO-25	MI5 Define	E-Stop	E-Stop	E-Stop	E-Stop	E-Stop	E-Stop	E-Stop	E-Stop	E-Stop	E-Stop
IO-26	MI6 Define	XCEL-L	XCEL-L	XCEL-L	XCEL-L	XCEL-L	XCEL-L	XCEL-L	XCEL-L	XCEL-L	XCEL-L
IO-27	MI7 Define	None	None	None	None	None	None	None	None	None	None
IO-28	MI8 Define	None	None	None	None	None	None	None	None	None	None
IO-29	FO Enable	Disable	Disable	Disable	Disable	Disable	Disable	Disable	Disable	Disable	Disable
IO-30	FO Frequency	60 Hz	60 Hz	60 Hz	60 Hz	60 Hz	60 Hz	60 Hz	60 Hz	115 Hz	115 Hz
IO-31	FO Fault Retry	10	10	10	10	10	10	10	10	10	10
IO-32	FO Retry Delay	60 Sec	60 Sec	60 Sec	60 Sec	60 Sec	60 Sec	60 Sec	60 Sec	60 Sec	60 Sec
IO-33	FO Mode & Reset	PID Off Auto	PID On Auto	PID On Auto	PID On Auto	PID On Auto	PID On Auto	PID On Auto	PID Off Auto	PID Off Auto	PID On Auto
IO-34	FO PID Setpoint	0%	0%	0%	0%	0%	0%	0%	0%	0%	0%
IO-36	Damper Mode	Disable	Enable	Enable	Disable	Disable	Disable	Disable	Disable	Disable	Disable
IO-37	Damper T-Delay	60 Sec	60 Sec	60 Sec	60 Sec	60 Sec	60 Sec	60 Sec	60 Sec	60 Sec	60 Sec
IO-38	No-Flow Mode	Disable	Disable	Disable	Disable	Disable	Disable	Disable	Disable	Disable	Disable
IO-39	Prime Time	20 Sec	20 Sec	20 Sec	20 Sec	20 Sec	20 Sec	20 Sec	20 Sec	20 Sec	20 Sec
IO-40	No-Flow Freq	20 Hz	20 Hz	20 Hz	20 Hz	20 Hz	20 Hz	20 Hz	20 Hz	20 Hz	20 Hz
IO-41	Lube/S-Clean	Disable	Disable	Disable	Disable	Disable	Disable	Disable	Disable	Disable	Disable
IO-42	S-Clean Timer	60 Min	60 Min	60 Min	60 Min	60 Min	60 Min	60 Min	60 Min	60 Min	60 Min
IO-43	Pre-Lube Timer	30 Sec	30 Sec	30 Sec	30 Sec	30 Sec	30 Sec	30 Sec	30 Sec	30 Sec	30 Sec
IO-44	Run-Lube Timer	0 Sec	0 Sec	0 Sec	0 Sec	0 Sec	0 Sec	0 Sec	0 Sec	0 Sec	0 Sec
IO-45	Post-Lube Timer	0 Sec	0 Sec	0 Sec	0 Sec	0 Sec	0 Sec	0 Sec	0 Sec	0 Sec	0 Sec
IO-47	Relay RA1	Fault	Fault	Fault	Fault	Fault	Fault	Fault	Fault	Fault	Fault
IO-48	Relay RA2	Run	Run	Run	Run	Run	Run	Run	Run	Run	Run
IO-49	Relay RA3	FDT-4	FDT-4	FDT-4	FDT-4	FDT-4	FDT-4	FDT-4	FDT-4	FDT-4	FDT-4
IO-59	AFM1 Out Select	Output Hz	Output Hz	Output Hz	Output Hz	Output Hz	Output Hz	Output Hz	Output Hz	Output Hz	Output Hz
IO-60	AFM1 Gain	100%	100%	100%	100%	100%	100%	100%	100%	100%	100%
IO-61	AFM2 Out Select	ACI %	ACI %	ACI %	ACI %	ACI %	ACI %	ACI %	ACI %	ACI %	ACI %
IO-62	AFM2 Gain	100%	100%	100%	100%	100%	100%	100%	100%	100%	100%
IO-63	AFM1 mA Select	4-20mA	4-20mA	4-20mA	4-20mA	4-20mA	4-20mA	4-20mA	4-20mA	4-20mA	4-20mA
IO-64	AFM2 mA Select	4-20mA	4-20mA	4-20mA	4-20mA	4-20mA	4-20mA	4-20mA	4-20mA	4-20mA	4-20mA
IO-72	FO Bypass Enable	Disable	Disable	Disable	Disable	Disable	Disable	Disable	Disable	Disable	Disable
IO-73	FO Bypass Delay	0 Sec	0 Sec	0 Sec	0 Sec	0 Sec	0 Sec	0 Sec	0 Sec	0 Sec	0 Sec

ADV Menu

Parameters in highlighted rows are reset when the application is changed [SET-00].

CODE	Display	Basic	Supply Fan	Exhaust Fan	Cooling Tower	Centrifugal Pump	Submersible Pump	Vacuum Pump	Constant Torque	PM Motor	PM Submersible
ADV-00	Upper Bound Int	100%	100%	100%	100%	100%	100%	100%	100%	100%	100%
ADV-01	PID Out Limit	100%	100%	100%	100%	100%	100%	100%	100%	100%	100%
ADV-02	Password Input	0	0	0	0	0	0	0	0	0	0
ADV-03	Parameter Reset	Disable	Disable	Disable	Disable	Disable	Disable	Disable	Disable	Disable	Disable
ADV-05	Password Lock	Unlocked	Unlocked	Unlocked	Unlocked	Unlocked	Unlocked	Unlocked	Unlocked	Unlocked	Unlocked
ADV-06	Acc/Dec Type	Linear	Linear	Linear	Linear	Linear	Linear	Linear	Linear	Linear	Linear
ADV-07	Acc/Dec Format	Unit 0.1 sec	Unit 0.1 sec	Unit 0.1 sec	Unit 0.1 sec	Unit 0.1 sec	Unit 0.1 sec	Unit 0.1 sec	Unit 0.1 sec	Unit 0.1 sec	Unit 0.1 sec
ADV-08	EnergySave	Disable	Disable	Disable	Disable	Disable	Disable	Disable	Disable	Disable	Disable
ADV-09	EnergySave Gain	100%	100%	100%	100%	100%	100%	100%	100%	100%	100%
ADV-10	MMC Mode	Disable	Disable	Disable	Disable	Disable	Disable	Disable	Disable	Disable	Disable
ADV-11	Motor Quantity	1	1	1	1	1	1	1	1	1	1
ADV-12	Aux Mtr Stop Hz	0	0	0	0	0	0	0	0	0	0
ADV-13	Alt Run Time	720 min	720 min	720 min	720 min	720 min	720 min	720 min	720 min	720 min	720 min
ADV-14	S-Start ON Dly	1 sec	1 sec	1 sec	1 sec	1 sec	1 sec	1 sec	1 sec	1 sec	1 sec
ADV-15	S-Start Off Dly	1 Sec	1 Sec	1 Sec	1 Sec	1 Sec	1 Sec	1 Sec	1 Sec	1 Sec	1 Sec
ADV-16	Mtr Switch Tmr	10 Sec	10 Sec	10 Sec	10 Sec	10 Sec	10 Sec	10 Sec	10 Sec	10 Sec	10 Sec
ADV-17	Mtr Switch Hz	60 Hz	60 Hz	60 Hz	60 Hz	60 Hz	60 Hz	60 Hz	60 Hz	115 Mz	115 Hz
ADV-18	Lag Start Freq	59.5 Hz	59.5 Hz	59.5 Hz	59.5 Hz	59.5 Hz	59.5 Hz	59.5 Hz	59.5 Hz	114 Hz	114 Hz
ADV-19	Lag Start Delay	10 Sec	10 Sec	10 Sec	10 Sec	10 Sec	10 Sec	10 Sec	10 Sec	10 Sec	10 Sec
ADV-20	Lag Start Level	2%	2%	2%	2%	2%	2%	2%	2%	2%	2%
ADV-21	Lead Freq Drop	10 Hz	10 Hz	10 Hz	10 Hz	10 Hz	10 Hz	10 Hz	10 Hz	10 Hz	10 Hz
ADV-22	MMC Dec Time	2 Sec	2 Sec	2 Sec	2 Sec	2 Sec	2 Sec	2 Sec	2 Sec	2 Sec	2 Sec
ADV-23	Lag Stop Freq	35 Hz	35 Hz	35 Hz	35 Hz	35 Hz	35 Hz	35 Hz	35 Hz	70 Hz	70 Hz
ADV-24	Lag Stop Delay	4 Sec	4 Sec	4 Sec	4 Sec	4 Sec	4 Sec	4 Sec	4 Sec	4 Sec	4 Sec
ADV-25	Lag Stop Level	0.3%	0.3%	0.3%	0.3%	0.3%	0.3%	0.3%	0.3%	0.3%	0.3%
ADV-26	Lead Freq Bump	0.0 Hz	0.0 Hz	0.0 Hz	0.0 Hz	0.0 Hz	0.0 Hz	0.0 Hz	0.0 Hz	0.0 Hz	0.0 Hz
ADV-27	MMC Accel Time	2 Sec	2 Sec	2 Sec	2 Sec	2 Sec	2 Sec	2 Sec	2 Sec	2 Sec	2 Sec
ADV-28	Power on Delay T	10 Sec	10 Sec	10 Sec	10 Sec	10 Sec	10 Sec	10 Sec	10 Sec	10 Sec	10 Sec
ADV-29	Run Delay Timer	0 Sec	0 Sec	0 Sec	0 Sec	0 Sec	0 Sec	0 Sec	0 Sec	0 Sec	0 Sec
ADV-30	Backspin Timer	0 Sec	0 Sec	0 Sec	0 Sec	0 Sec	0 Sec	0 Sec	0 Sec	0 Sec	0 Sec
ADV-31	Aux Timer Type	On-Delay	On-Delay	On-Delay	On-Delay	On-Delay	On-Delay	On-Delay	On-Delay	On-Delay	On-Delay
ADV-32	Aux Timer Time	10 Sec	10 Sec	10 Sec	10 Sec	10 Sec	10 Sec	10 Sec	10 Sec	10 Sec	10 Sec
ADV-33	Aux Timer Input	FWD DI	FWD DI	FWD DI	FWD DI	FWD DI	FWD DI	FWD DI	FWD DI	FWD DI	FWD DI
ADV-34	Min Run Timer	0 Sec	0 Sec	0 Sec	0 Sec	0 Sec	0 Sec	0 Sec	0 Sec	0 Sec	0 Sec
ADV-35	Multi-VFD Set	Single VFD	Single VFD	Single VFD	Single VFD	Single VFD	Single VFD	Single VFD	Single VFD	Single VFD	Single VFD
ADV-36	Standby Pumps	0	0	0	0	0	0	0	0	0	0
ADV-37	Multi-VFD ID	1	1	1	1	1	1	1	1	1	1
ADV-38	VLag Start Freq	59.5 Hz	59.5 Hz	59.5 Hz	59.5 Hz	59.5 Hz	59.5 Hz	59.5 Hz	59.5 Hz	114 Hz	114 Hz
ADV-39	VLag Start Delay	10 Sec	10 Sec	10 Sec	10 Sec	10 Sec	10 Sec	10 Sec	10 Sec	10 Sec	10 Sec
ADV-40	VLag Stop Freq	35 Hz	35 Hz	35 Hz	35 Hz	35 Hz	35 Hz	35 Hz	35 Hz	70 Hz	70 Hz
ADV-41	VLag Stop Delay	5 Sec	5 Sec	5 Sec	5 Sec	5 Sec	5 Sec	5 Sec	5 Sec	5 Sec	5 Sec
ADV-42	VLead/Lag ID	Lead	Lead	Lead	Lead	Lead	Lead	Lead	Lead	Lead	Lead
ADV-43	VLag Speed	PID	PID	PID	PID	PID	PID	PID	PID	PID	PID
ADV-44	VLag Set Freq	55 Hz	55 Hz	55 Hz	55 Hz	55 Hz	55 Hz	55 Hz	55 Hz	110 Hz	110 Hz
ADV-45	Alternation	Disable	Disable	Disable	Disable	Disable	Disable	Disable	Disable	Disable	Disable
ADV-46	Alternate TMR	24 Hour	24 Hour	24 Hour	24 Hour	24 Hour	24 Hour	24 Hour	24 Hour	24 Hour	24 Hour
ADV-47	Master Ready	Ready	Ready	Ready	Ready	Ready	Ready	Ready	Ready	Ready	Ready
ADV-48	Jockey Mode	Disable	Disable	Disable	Disable	Disable	Disable	Disable	Disable	Disable	Disable
ADV-49	J-Start Press	54 (unit)	54 (unit)	54 (unit)	54 (unit)	54 (unit)	54 (unit)	54 (unit)	54 (unit)	54 (unit)	54 (unit)
ADV-50	J-Start Freq	50 Hz	50 Hz	50 Hz	50 Hz	50 Hz	50 Hz	50 Hz	100 Hz	100 Hz	100 Hz
ADV-51	Main Stop Freq	40 Hz	40 Hz	40 Hz	40 Hz	40 Hz	40 Hz	40 Hz	80 Hz	80 Hz	40 Hz
ADV-52	J-Start Delay	20 Sec	20 Sec	20 Sec	20 Sec	20 Sec	20 Sec	20 Sec	20 Sec	20 Sec	20 Sec
ADV-53	Main Stop Delay	5 Sec	5 Sec	5 Sec	5 Sec	5 Sec	5 Sec	5 Sec	5 Sec	5 Sec	5 Sec

Safety Information

This equipment should be installed and serviced by technically qualified personnel who are familiar with the correct selection and use of appropriate tools, equipment, and procedures. Failure to comply with national and local electrical and plumbing codes and within Franklin Electric recommendations may result in electrical shock or fire hazard, unsatisfactory performance, or equipment failure.

Read and follow instructions carefully to avoid injury and property damage. Do not disassemble or repair unit unless described in this manual.

Failure to follow installation or operation procedures and all applicable codes may result in the following hazards:

⚠ WARNING



High voltages capable of causing severe injury or death by electrical shock are present in this unit.

- To reduce risk of electrical shock, disconnect power before working on or around the system. More than one disconnect switch may be required to de-energize the equipment before servicing.
- Serious or fatal electrical shock may result from failure to connect the ground terminal to the motor, drive, metal plumbing, or other metal near the motor or cable, using wire no smaller than motor cable wires.
- Do not remove or install VFD cover for wiring, periodic inspections, or adjustments while power is applied, or the unit is in operation.
- Capacitors inside the drive can still hold lethal voltage even after power has been disconnected—ALLOW 10 MINUTES FOR DANGEROUS INTERNAL VOLTAGE TO DISCHARGE BEFORE REMOVING COVER.
- Operate VFD and control devices with dry hands.
- Do not use VFD if power or motor cable is damaged.
- Do not apply power to a damaged VFD or to VFD with missing parts.
- Perform wiring after VFD has been mounted. Otherwise, electric shock or bodily injury can occur.

⚠ CAUTION



Risk of bodily injury, electric shock, or property damage.

- This equipment must not be used by children or persons with reduced physical, sensory or mental abilities, or lacking in experience and expertise, unless supervised or instructed. Children may not use the equipment, nor may they play with the unit or in the immediate vicinity.
- Equipment can start automatically. Lockout-Tagout before servicing equipment.
- This equipment produces high temperatures during normal operation. Use caution when contacting surfaces.
- Do not allow lint, paper, wood chips, dust, metallic chips or other foreign material into the drive.
- Some VFD parameters are set as default to automatically start VFD in some applications. Disable these parameters if automatic start is not safe for personnel or equipment

NOTICE

Risk of damage to drive or other equipment.

- Take protective measures against ESD (Electrostatic Discharge) before touching control boards during inspection, installation or repair.
- Set correct motor data from the motor nameplate and overload protection parameters for proper motor overload protection.
- Use, if possible, an inverter rated or motor with insulation Class F or higher. For submersible pump motors, use Class B or higher. The VFD generates high frequency output pulses with spikes, which can deteriorate motor winding insulation and eventually damage the motor. The longer distance to the motor the higher amplitude of these voltage spikes will be applied to motor winding. Any cables with paralleled wires will increase the amplitude of these spikes at motor terminals.
- The VFD can operate a motor at frequencies higher than 50Hz or 60Hz. Verify the maximum allowed speed with motor and machinery manufacturers prior to increasing output frequency because it can overheat the motor or damage machinery.

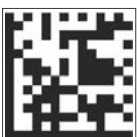

For technical assistance, parts, or repair, please contact:

800.348.2420 | franklin-electric.com

Form 10000005066 Rev. 000 08/20



Franklin Electric

Copyright © 2020, Franklin Electric, Co., Inc. All rights reserved.