

A11 Series Low Temperature Cutout Control

Installation Instructions

Part No. 997-358, Rev. E
Issued July 20, 2009
Supersedes July, 1990

Applications

IMPORTANT: All Series A11 temperature controls are designed for use **only** as operating controls. Where an operating control failure would result in personal injury and/or loss of property, it is the responsibility of the installer to add devices (safety, limit controls) or systems (alarm, supervisory systems) that protect against, or warn of, control failure.

A11 Series low temperature cutout controls are available with Single-Pole, Double-Throw (SPDT) or Single-Pole, Single-Throw (SPST) contact action. Typical applications include the sensing of low temperature conditions to avoid overcooling or icing of hydronic coils, cooling coils, and liquid handling pipes. The controls are compact and sturdy, and have an adjustable temperature setpoint range with a fixed differential. The range adjustment screw is accessible at the bottom of the control, and at the top of the control when the cover is removed.

Installation

Special Tools Needed

- 1.3 cm (1/2 in.) EMT bender
- hole saw
- tin snips or hack saw
- vise
- brackets
- 4 in. (10.1 cm) electrical box covers with a center hole knockout, or T-752-1001 1/2 in. (1.3 cm) Duct Flanges
- nylon tie wraps with holes
- 1/2 in. (1.3 cm) EMT connectors
- 1/4 in. (6.4 mm) poly tubing
- copper tubing
- EMT or Unistrut
- conduit hangers or Minerallac straps
- self-tapping sheet metal screws

- machine screws and nuts
- A11 Low Temperature Cutout Control
- TE-6001-8 Element Mounting Bracket

Mounting

Locate the bulb on the downstream side of the coil with the bulb exposed to all areas where low temperatures are likely to be encountered. Horizontally serpentine the 20 ft (6.1 m) long sensing element across the face of the coil to sense temperatures in all areas. The horizontal pitch of the coil should not exceed five degrees (one inch per foot) for those areas to be protected. See Figure 1.

Do not install A11 Series controls where the ambient temperature at the control exceeds 140°F (60°C), or falls below 0°F (-18°C). The maximum temperature at the sensing bulb should not exceed 250°F (121°C).

Mounting Considerations

The primary purpose of a low limit cutout is to prevent a coil from freezing. Therefore, before mounting the control, you need to consider several factors that help protect the coil from freezing.

- Cool air drops to the bottom of the unit. This is why protection in the lower bottom of the unit (lower 6 in. or 15.2 cm) is vital.
- If the tubes in the coil freeze, the coil can crack and begin leaking. As water leaks from the coil, the control system may sense the reduced water pressure and increase the flow of water to compensate for the loss, which causes even more damage.
- You must install low limit controls in a very specific manner to perform their intended task. The low limit controls incorporate a vapor-charged sensing element. The vapor in the element creates a change in pressure with a change in temperature within the sensing element, eventually causing the electrical switch in the device to open or close. This design feature is the reason that the device must be installed properly so that it functions as intended.

- The size of the duct work or air handling unit system in which the device is installed may require more than one low limit control to adequately protect the entire coil.
- System accessibility affects how the device is mounted. Larger Air Handling Units (AHUs) often provide access to the coil, allowing you to effectively serpentine the capillary across its face. (See *Mounting in an Accessible Location.*) Smaller AHUs or duct work may not provide direct accessibility, which means you need to pre-assemble the control before installation. (See *Mounting in an Inaccessible Location.*)
- Mount the sensing element with a slight decline of approximately 1 inch (25 mm) for every 1 foot (305 mm) of drop, as illustrated in Figure 1 and listed in Table 1.

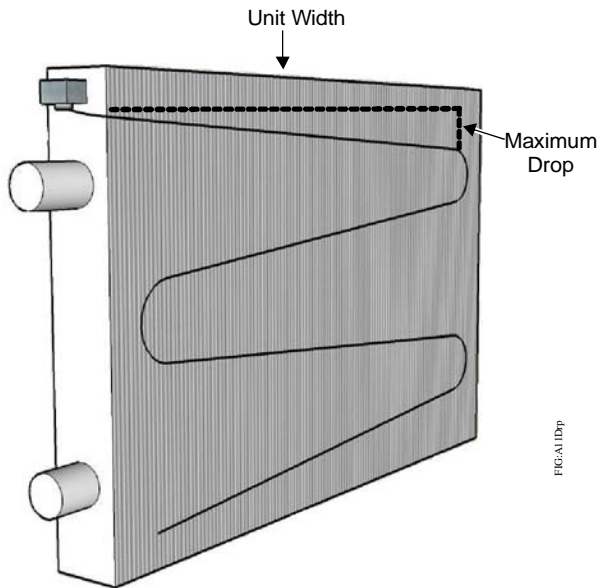

Figure 1: Mounting Sensing Element Inside Coil

Table 1: Maximum Drop by Unit Width

Unit Width, Feet (Meters)	Maximum In. (mm) of Drop per Segment ¹
5 (1.5)	5.25
10	10.50
15	15.75
20	21.00
25	26.25
30	31.50

1. As a general rule, allow for 1 inch (25 mm) of drop per 1 foot (305 mm) of run.

- Alternate installations are shown in Figure 2 and Figure 3. If you select these installation methods, mount the temperature control above the sensing element whenever possible. If you cannot mount the control above the element, loop the capillary/element slightly below the control, then route the element toward the top of the coil, and begin serpentering in a downward direction from the top of the coil.

Keep the loop as short as possible (maximum of 4 feet). If you mount the control below the sensing element, prevent possible nuisance alarms by mounting the control in a conditioned space. When using the A11 Series control, coil the excess capillary (small capillary between the control and sensing element) inside the conditioned space and secure.

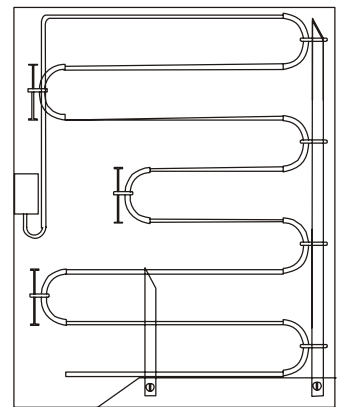

Control mounted inside duct, duct surrounded by unconditioned space

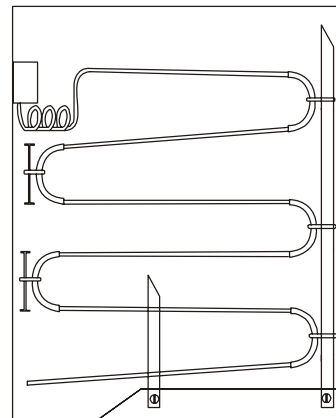

Control mounted inside duct, space surrounding duct is unconditioned

Figure 2: Mounting Options - Inside a Duct

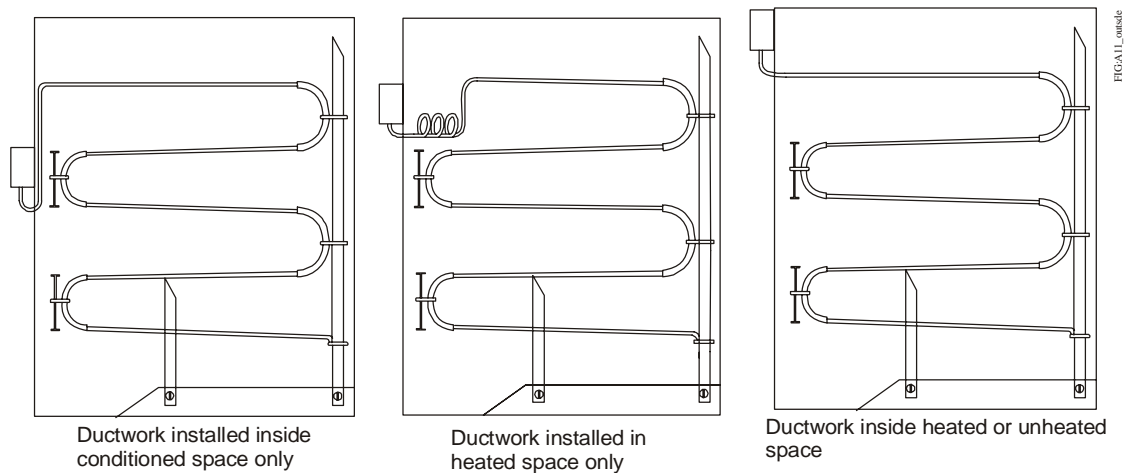

Figure 3: Mounting Options - Outside the Duct

Mounting Guidelines



CAUTION: Risk of Environmental and Property Damage

Avoid sharp bends in capillary tubes. Sharp bends can weaken or kink capillary tubes, which may result in refrigerant leaks or restrictions of flow.



CAUTION: Risk of Environmental and Property Damage

Coil and secure excess capillary tubing away from contact with sharp or abrasive objects or surfaces. Vibration and sharp or abrasive objects in contact with capillary tubes can cause damage that may result in release of the chemical charge in the sensing element, which may result in damage to the environment or property.



CAUTION: Risk of Property Damage

Do not dent or deform the sensing bulb. Dents or deformations in the sensing bulb can change the calibration, may cause the control to operate at temperatures other than the setpoint, and may result in other property damage.

IMPORTANT: Be careful when drilling holes or driving screws while mounting sensing elements to avoid puncturing or damaging hydronic coils.

IMPORTANT: Use only the mounting screws supplied with the Universal Mounting Bracket to avoid damaging internal components. Be careful not to distort or bend the control case when mounting the control to an uneven surface. Using other screws or bending the control case voids the warranty.

IMPORTANT: Locate the control case and bellows where the ambient temperature is always warmer than the setpoint. The control operates only from the lowest temperature along any 14 to 16 in. length of the sensing element.

IMPORTANT: Locate Low temperature cutout controls in areas protected from the effects of weather. If the control is mounted in an area that is exposed to the weather or other wet environments, it must be equipped with an outdoor enclosure.

IMPORTANT: It is important to mount the low temperature cutout control in the correct location. The capillary must be exposed to all areas on the coil where a risk of low temperatures is present.

Observe the following guidelines when mounting A11 Series low temperature cutout controls.

- Mount the control upright in an accessible location, where the control body, capillary tube, and sensing bulb are not subject to damage, and the control is in the highest possible position of the entire installation.
- Mount the control upstream from mixed air or chilled water coils.
- Mount the control downstream from preheat coils.

- Mount the control upright on flat, vertical, or horizontal surfaces using accessory brackets. These controls have NEMA 1 enclosures.
- Mount the capillary in a serpentine fashion so that it slopes gently downhill (not to exceed 5°); has no dips, bends, or kinks; and the last segment is installed within 15.2 cm (6 in.) of the bottom of the coil.

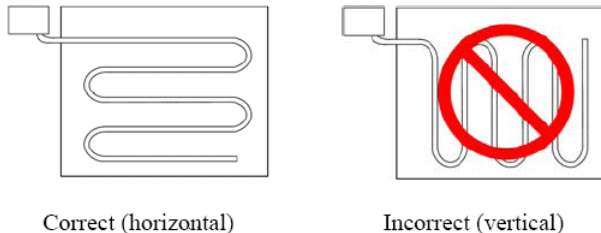

Figure 4: Correct Control Capillary Orientation

Mounting in an Accessible Location

Sometimes, the coil face offers nothing that can hold the tie-wrapped sensing element. In these cases, use 1.3 cm (1/2 in.) EMT, hard copper tubing, or Unistrut to build supports to be used for fastening the sensing element. Fastening the sensing element to fixed supports holds the element in place, preventing movement in the air stream. Field-fabricated supports often take the form of a rack with vertical supports.

Once you determine the proper location, follow these guidelines to mount an A11 Series low temperature cutout control (also see Figure 1):

1. Use two screws or bolts through the two outer holes on the back of the control case when mounting the control directly to a flat vertical surface.
2. Use the two inner holes with the mounting bracket (and screws supplied) when mounting the control to a flat horizontal surface.
3. Determine the best mounting location for the low temperature cutout control. Locate the control as high as possible on the side of the duct or on a nearby wall, panel, or structural support. The desired mounting position is with the element bellows pointing down.
4. Build and install any field-fabricated supports that are necessary to hold the sensing element in place.
5. Using the control's mounting bracket as a template, mark the location for the mounting screws.

6. Drill an 8 mm (5/16 in.) entry hole for the sensing element.
7. Feed the entire length of the sensing element through the entry hole.

IMPORTANT: On an A11 low temperature cutout control, the brass tubing just below the bellows is not temperature sensitive and can be mounted in ambient temperature. Below the solder bead, the copper sensing element begins. This part is temperature-sensitive, and you must properly position it to work correctly.

8. Fasten the control to the side of the duct using the mounting bracket and self-tapping screws.
 9. Secure the far end of the sensing element, starting at the bottom of the coil.
 10. Secure the sensing element with 6.4 mm (1/4 in.) poly sleeve and tie wraps.
 11. Position and mount the sensing element within 15.2 cm (6 in.) of the bottom of the coil.
 12. Work your way back up to the bellows, stringing the sensing element in a serpentine fashion horizontally across the face of the coil, as shown in Figure 4.
 13. Successive horizontal runs of the sensing element should be inclined slightly upward.
 14. Make sure that horizontal runs of the sensing element are no more than 30.5 cm (12 in.) away from each other.
- Note:** On a wide coil, you could be left with a very small **S** to get back up to the control. Locate this topmost bend in the correct position to use up any remaining slack in the length of the sensing element. You may need to build a support for the bracket at that turning point.
15. To prevent damage caused by vibration or abrasion, place a short piece of 3.2 mm (1/4 in.) poly sleeve around the capillary at the point where it passes through the entry hole in the duct work. Slit the tubing lengthwise to permit easy installation. Caulking or sealant is normally not needed when the right size hole and tubing are used.
 16. At the bends, use a TE-6001-8 Averaging Element Mounting Bracket to obtain the correct radius and protect the sensing element. The radius of each bend of the sensing element must be at least 7.6 cm (3 in.), but not exceed 35.5 cm (14 in.).

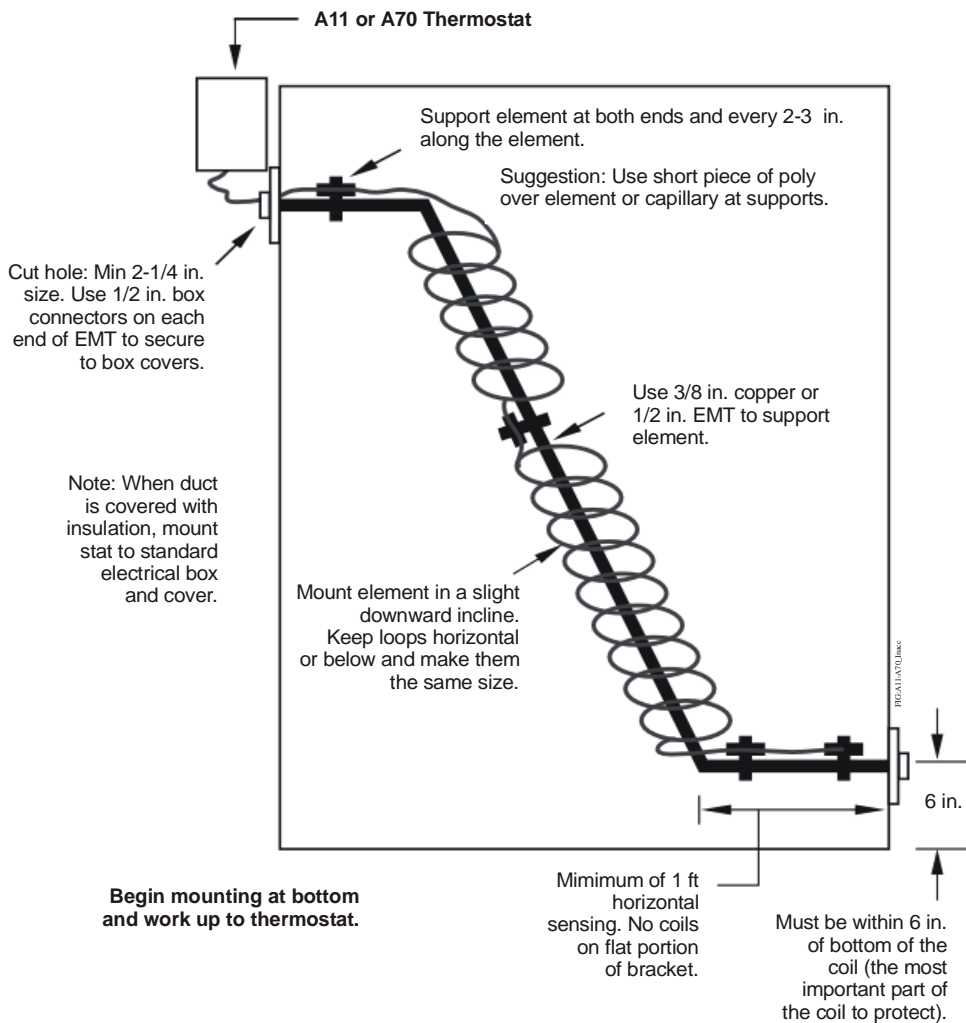

Figure 5: Mounting Low Temperature Cutout Controls in Small Ducts with Inaccessible Coils

Mounting in an Inaccessible Location

1. Determine the mounting location for the low limit control.
 - Stay clear of any moving parts within the duct, such as dampers.
 - When the duct is covered with insulation, mount the control to a standard electrical 4-Square box and cover.
2. Using Figure 5 as a guide, measure the duct and calculate the required length and height of the element support.
3. Using 1.3 cm (1/2 in.) EMT, build the support assembly outside of the duct.

Note: 1 cm (3/8 in.) hard copper tubing can be substituted for 6.4 mm (1/2 in.) EMT when building the support. These instructions assume the use of EMT.

4. Starting at the bottom of the coil, distribute the sensing element around the support and tie-wrap it securely in place. Keep the loops horizontal or inclined slightly downward (not to exceed 5°) and uniform in size (see Figure 5).
5. Consider the use of Minerallac conduit hangers or equivalent to provide anchoring points on the support where needed.
6. Place a 1.3 cm (1/2 in.) EMT connector on each end of the support. These connectors protrude through the knockout hole on the 10.1 cm (4 in.) box covers, which are used as mounting plates at each end of the support.

7. At the upper end of the duct, using a large hole saw (5.7 cm [2-1/4 in.] minimum), drill the entry hole for the sensing element/support assembly.
8. At the lower end of the duct, drill another hole (use the same hole saw as used to cut the entry hole).
9. A larger hole allows easier access for mounting. Position this hole to allow the lower portion of the sensing element to be within 15.3 cm (6 in.) of the bottom of the coil.
10. Cut a notch in another 10.1 cm (4 in.) box cover. The notch is used to secure the upper end of the support assembly. Locate the notch so that you can position the capillary (whip) close to the support. See Figure 6.
11. Place a 10.1 cm (4 in.) box cover, with the center knockout removed, over the upper end of the support assembly, and use a lock nut to fasten the support to the box cover.
12. Feed the sensing element/support assembly through the entry hole at the upper end, and position the lower end of the support to protrude through the exit hole at the bottom on the far side.
13. Place a 10.1 cm (4 in.) box cover with the center knockout removed over the end of the support and, using a lock nut, fasten the support in place at the lower end.

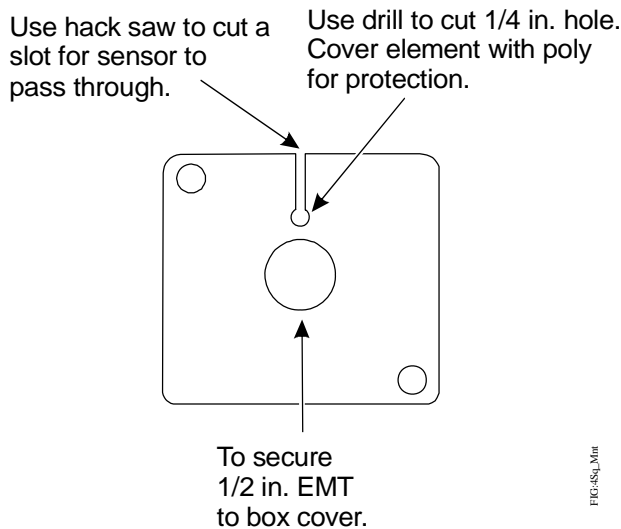

Figure 6: Details on 4-Square Cover Upper Mount with Center 1/2 in. Knockout.

14. Carefully place the capillary tube in the slot and apply a short piece of 6.4 mm (1/4 in.) poly tubing, slit lengthwise, around the capillary where it passes through the notch.

15. Screw down the corners of the box cover to hold the upper end of the support assembly in place.
16. Using the mounting bracket, fasten the control to the side of the duct using self-tapping screws, ensuring a downhill element all the way to the bottom of the control.

Wiring

For most AHU installations, it is more cost-effective to wire the Low Limit (and other safeties) with low voltage Class 2 wiring and add a shutdown relay at the Motor Starter.

This practice allows the control to share raceways with other low voltage cables for the system.



CAUTION: Risk of Electric Shock

Disconnect power supply before making electrical connections to avoid electric shock.

IMPORTANT: Make all wiring connections in accordance with local, national, and regional regulations. Do not exceed the electrical ratings.

Setup and Adjustments

IMPORTANT: Do not adjust the pointer beyond the highest or lowest indicator marks on the control's temperature scale. Adjusting the pointer beyond the indicator marks may damage screw threads, may cause inaccurate control operation, and voids the warranty. Also, most controls with spot sensitive sensing elements used for coil protection are set and sealed at 1.6°C (35°F). Attempting to set them lower can damage the control.

IMPORTANT: After adjusting the control settings and before leaving installation, verify equipment and control operation, and verify control setpoint with a reliable thermometer.

Adjust the setpoint by turning the adjustment screw until the pointer is opposite the desired cutout point. Access the adjustment screw at the bottom of the control or at the top when the cover is removed.

Checkout Procedure

Before leaving the installation, observe at least three complete operating cycles to be sure that all components are functioning correctly. When used as a low temperature cutout control, simulate operation by actuating contacts to confirm that electrical connections are correct.

Operation

The A11D and A11E models have SPDT contact action; models A11A and A11B have SPST contacts. When 16 inches (406 mm) or more of an A11 control's sensing bulb senses a temperature equal to or lower than the setpoint, the contacts open on SPST controls, or the circuit between the Red and Yellow terminals open on SPDT controls.

The A11A and A11D models lock out when the temperature decreases below the control's temperature setpoint. You must manually reset these models by pressing and then releasing the reset lever after the temperature increases 12F° (6.7C°) or more above the setpoint. The A11B and A11E automatically recycle on an increase in temperature.

Table 2: A11 Series Low Temperature Cutout Controls¹

Code Number	Switch Action	Range	Differential °C (°F)	Maximum Bulb Temperature	Range Adjuster
A11A-1C	SPST Open Low	2 to 7°C (35 to 45°F)	Manual Reset	121°C (250°F)	Screwdriver slot
A11B-1C			12°C (6.7°F) Fixed		
A11D-5C	SPDT		Manual Reset		
A11E-5C			12°C (6.7°F) Fixed		

1. A11 Series low temperature cutout controls have 6.1 m of 3.2 mm O.D. Tubing and 1.2 m Capillary (20 ft of 1/8 in. O.D. Tubing and 4 ft Capillary.)

Repair Information

If the A11 Series Low Temperature Cutout Control fails to operate within its specifications, replace the unit. For a replacement A11 Series Control, contact the nearest Johnson Controls® representative.

Technical Specifications

A11 Series Low Temperature Cutout Controls

Product Codes	A11A: SPST, Open Low, Manual Reset A11B: SPST, Open Low, Automatic Recycle A11D: SPDT, Manual Reset A11E: SPDT, Automatic Recycle
Range Cutout	35 to 45°F (2 to 7°C)
Differential	A11A, A11D: Temperature must be 12°F (6.7°C) above cutout point before control can be reset. A11B, A11E: 12°F (6.7°C)
Ambient Temperature	Minimum: 0°F (-18°C) Maximum: 140°F (60°C)
Maximum Temperature at Bulb	250°F (121°C)
Sensing Element	1/8 in. x 20 ft (3.2 mm x 6.1 m)
Capillary Length	4 ft (1.2 m)
Switch	Snap-acting contacts in dust-protected enclosure
Material	Case: 0.6 in. (1.6 mm) Cold Rolled Steel Cover: 0.3 in. (0.8 mm) Cold Rolled Steel
Finish	Galvanized Steel
Conduit Opening	22 mm (0.9 in.) hole for 12.7 mm (1/2 in.) conduit
Mounting Bracket	Standard on all controls
Shipping Weight	Individual Pack: 1.8 lb (0.8 kg) Overpack of 20 units: 38 lb (17 kg)
Electrical Rating	Pilot Duty: 125 VA, 24 to 277 VAC
Motor Ratings	AC Full Load Ampere: 120 V = 16.0 A; 208 V = 9.2 A, 240 V = 8.0 A AC Locked Rotor Ampere: 120 V = 96.0 A, 208 V = 55.2 A, 240 V = 48.0 A Non-Inductive Ampere: 120 V = 16.0 A, 208 V = 9.2 A, 240 V = 8.0 A

The performance specifications are nominal and conform to acceptable industry standard. For application at conditions beyond these specifications, consult the local Johnson Controls® office. Johnson Controls, Inc. shall not be liable for damages resulting from misapplication or misuse of its products.



Building Efficiency

507 E. Michigan Street, Milwaukee, WI 53202

Metasys® and Johnson Controls® are registered trademarks of Johnson Controls, Inc. All other marks herein are the marks of their respective owners. © 2009 Johnson Controls, Inc.