



VH7200 Humidistat Series For Humidification & Dehumidification Control For Commercial HVAC Applications

(Issue Date September 29, 2008 – 028-0208 R4)

Product overview

The VH7200 humidity controller family is specifically designed for control of humidification and dehumidification equipment such as steam header direct injection, desiccant wheel, or stand alone humidification / dehumidification equipment. The product features a complete embedded humidity control solution with an intuitive backlit LCD display that walks the installer through the configuration steps, making the process extremely simple. Accurate relative humidity control is achieved due to the product's unique PI time proportional control algorithm, which virtually eliminates humidity offset associated with traditional, differential-based humidity controllers.

All models contain a binary input, which can be set by the user to monitor an electrode humidifier canister service status or may be used as a general purpose service indicator. Models are available which contain more advanced features such as discharge humidity proportional high limit, and indoor humidity setpoint reset based upon outdoor air temperature to conserve energy and eliminate condensation on windows and structure.



Fig.1 VH7200 series humidistats

The additional following documents are available at: www.viconics.com

- Information on the BACnet models (VH72xxX1000B), is available on document *ITG-VH7200-BAC-Exx*

Models available

Application	Model Number	Humidification Output(s)	Dehumidification Output
Model with Outdoor reset & Proportional High Limit	VH7270K1000 (X)	0-10 Vdc & On/Off 24 Vac	On-Off 24 Vac
Model with Outdoor reset & Proportional High Limit	VH7270F1000 (X)	0-10 Vdc	On-Off 24 Vac
Models with outdoor reset only	VH7200A1000 (X)	On/Off 24 Vac	On-Off 24 Vac
* NEW * Duct Mount Model with Outdoor reset & Proportional High Limit	VH7270D1000 (X)	0-10 Vdc	On-Off 24 Vac

(X) model number represents available communication options: **X=none** for Stand-alone and **X=B** for BACnet MS-TP.

Features and benefits

Features	Benefits
• Embedded humidification and dehumidification sequences	⇒ Simplifies installation and reduce installation costs
• Embedded internal RH sensor	⇒ Eliminates components
• Proportional high limit override • (VH7270 Models Only)	⇒ Prevents costly damage due supply humidity condensation
• Humidity setpoint reset based on outdoor temperature	⇒ Saves energy and prevents window condensation in colder climates
• Sensor failure protection	⇒ Prevents water damage
• PI time proportioning algorithm	⇒ Increased comfort, accuracy, and energy savings
• Binary input	⇒ Adds functionality (Trigger service alarms)
• Unique configuration menu routine	⇒ Minimizes parameter tampering
• Lockable keypad	⇒ Tamper proof, no need for humidistat guards
• EEPROM memory	⇒ No loss configuration parameters
• Optional remote humidity sensors	⇒ Increase flexibility and functionality

Features overview

- Internal RH sensor and optional remote RH input with embedded humidification and dehumidification sequence of operation.
- Humidity set point reset based upon outdoor temperature sensing for added flexibility.
- Proportional high limit input to prevent over-humidification due to supply humidity condensation.
- Lockable keypads for tamper proofing. No need for extra humidistat guard.
- Programmable binary input for added flexibility. The input can be programmed as the following:
 - **None:** No function will be associated with the input
 - **Service:** a backlit flashing **Service** alarm will be displayed on the humidistat LCD screen when the input is energized. It can be tied in to the AC unit control card, which provides an alarm in case of malfunction.
 - **Canister:** a backlit flashing **Canister** alarm will be displayed on the humidistat LCD screen when the input is energized. It can be tied to a Dry contact output supplied by others.

Installation

- Remove security screw on the bottom of humidistat cover.
- Open up by pulling on the bottom side of humidistat.
- Remove Assembly and remove wiring terminals from sticker.

(Fig. 2)

A) Location:

- 1- Should not be installed on an outside wall.
- 2- Must be installed away from any heat source.
- 3- Should not be installed near an air discharge grill.
- 4- Should not be affected by direct sun radiation.
- 5- Nothing must restrain vertical air circulation to the humidistat.

B) Installation:

- 1- Swing open the humidistat PCB to the left by pressing the PCB locking tabs. **(Fig. 3)**
- 2- Pull out cables 6" out of the wall.
- 3- Wall surface must be flat and clean.
- 4- Insert cable in the central hole of the base.
- 5- Align the base and mark the location of the two mounting holes on the wall. Install proper side of base up.
- 6- Install anchors in the wall.
- 7- Insert screws in mounting holes on each side of the base.

(Fig. 3)

- 8- Gently swing back the circuit board on the base and push on it until the tabs lock it.
- 10- Strip each wire 1/4 inch.
- 11- Insert each wire according to wiring diagram.
- 13- Gently push back into hole excess wiring **(Fig. 4)**
- 14- Re-Install wiring terminals in correct location. **(Fig. 4)**
- 15- Reinstall the cover (top side first) and gently push back extra wire length into the hole in the wall.
- 16- Install security screw.

For VH7270D1000 duct-mount model only:

- 1- Make 1" diameter hole in duct wall
- 2- Insert the duct sensor and fix the electrical box to the duct wall in the vertical position (respect airflow direction).
- 3- Install the humidistat to the electrical box using the supplied screws (2).
- 4- Follow steps 1-16 above.

Note: For dimensions please see page 14

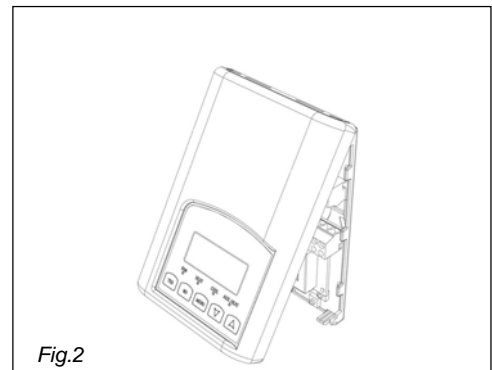

Fig.2

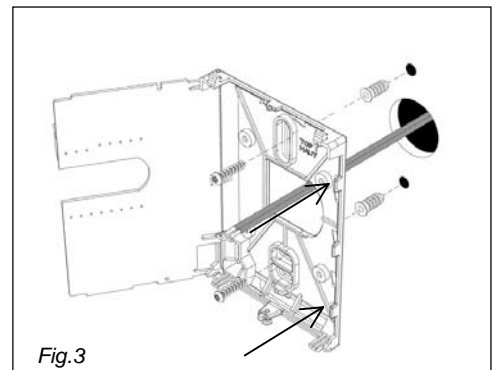

Fig.3

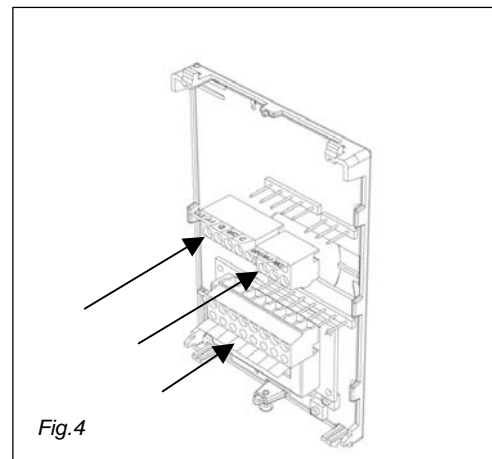

Fig.4

Wiring

Terminal identification & screw terminal arrangement

Part Number	VH7270K	VH7270D/F	VH7200A
Top left terminal block			
1	Not used	Not used	Not used
2	HUM	Not used	X
3	HUM	Not used	X
4	R	X	X
5	C	X	X
Top right terminal block			
6	DEH	X	X
7	DEH	X	X
8	Not used	Not used	Not used
Bottom terminal block			
9	Not used	Not used	Not used
10	Not used	Not used	Not used
11	HUM 0-10	X	Not used
12	DI1	X	X
13	HS	X	X
14	SCOM	X	X
15	OS	X	X
16	HL	X	Not used

Fig.5 : VH7200's wiring terminals

Wiring notes:

Note 1:
Reference of the analog 0-10 Vdc control signal is the common of the power supply of the humidistat. (terminal C)

Note 2:
Electromechanical dry contact is to be used with the binary input. Electronic triacs cannot be used as mean of switching for the input. The switched leg to the input for the input to activate is terminal Scom

Note 3:
The transformer of the unit provides power to the humidistat and any additional loads wired to the humidistat.

Note 4:
Both the remote humidity sensors (HS & HL terminals) use 0 to 10 Vdc type humidity sensors.

Detailed wiring diagram for model VH7270K1000

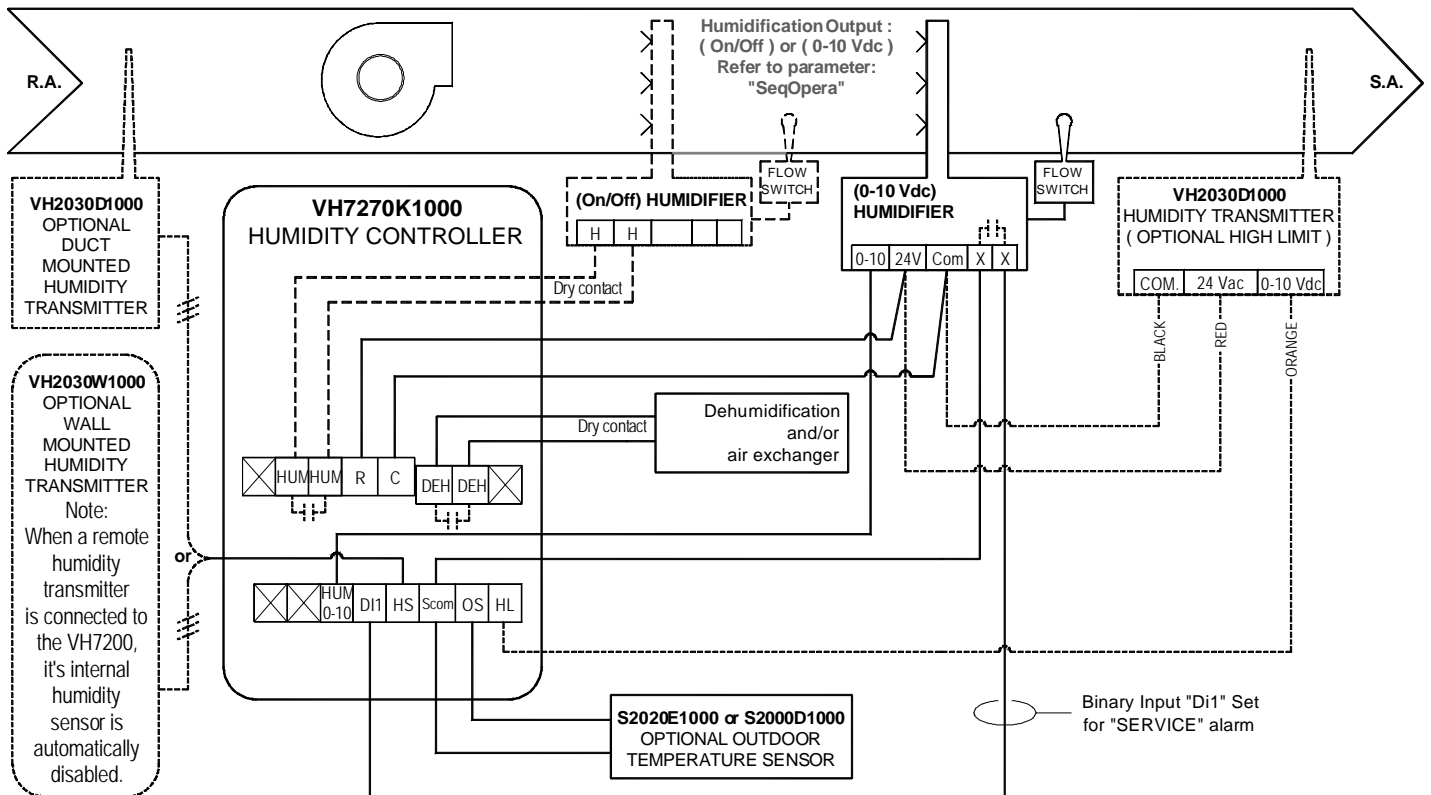
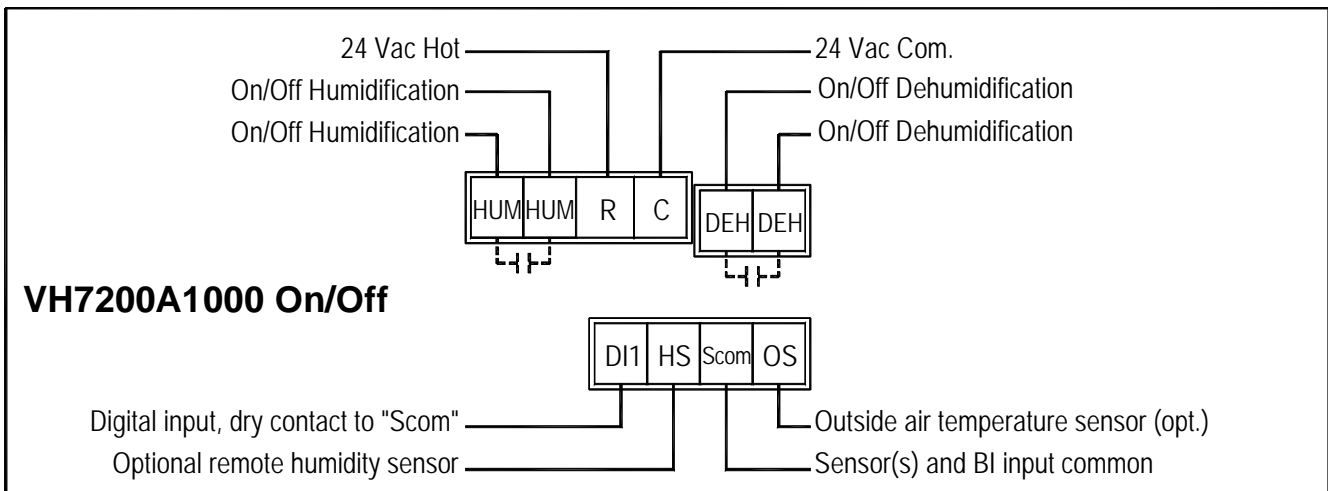
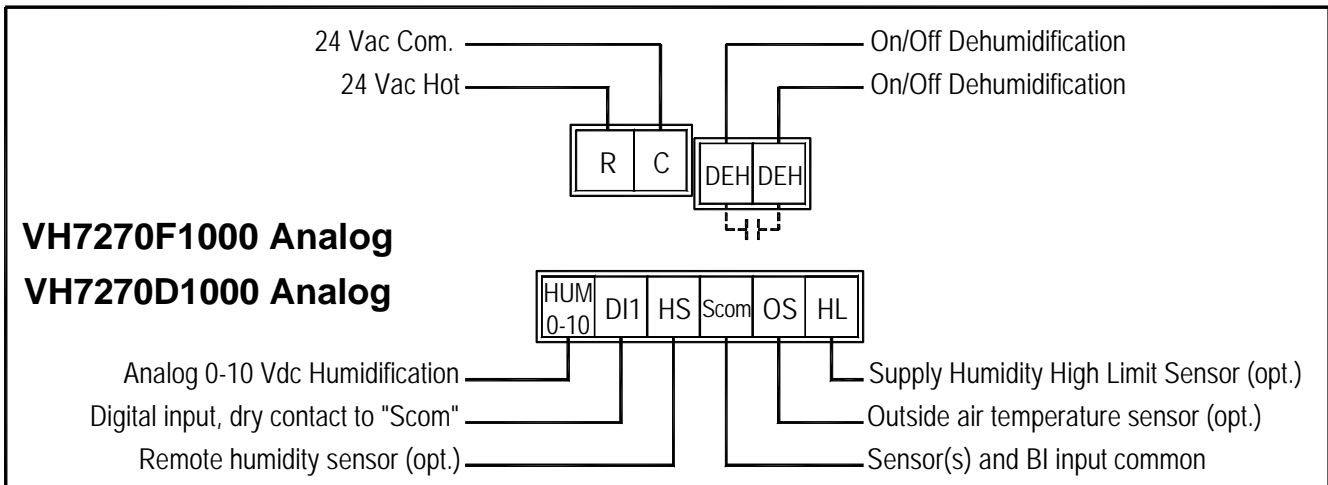
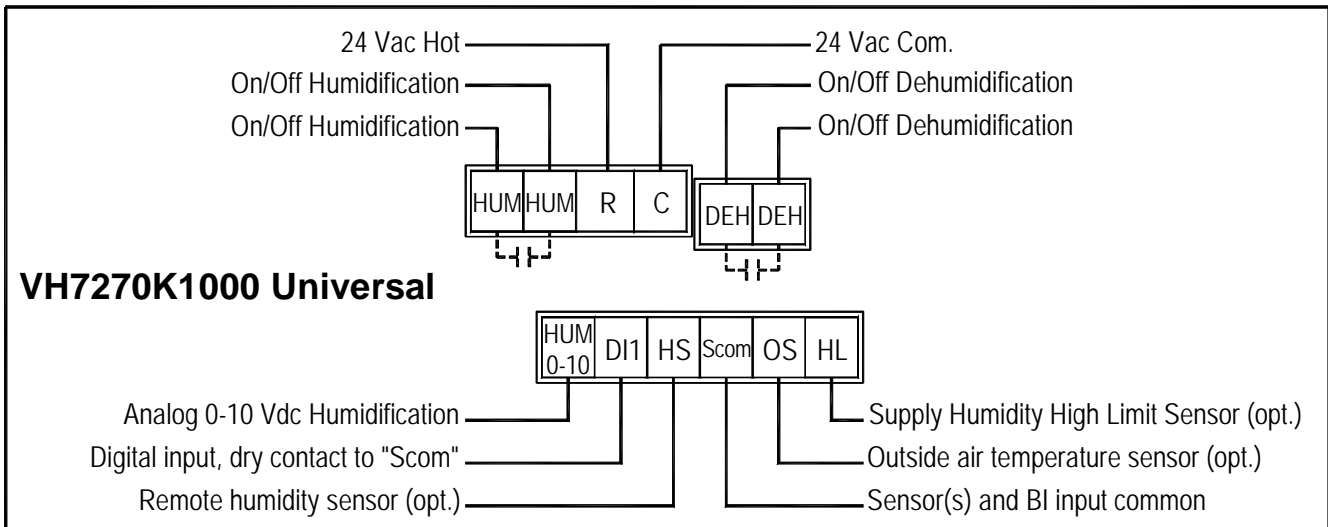

Fig.6 : VH7270F1000 wiring diagram



Remote humidity sensor accessories

Model number	Description:
VH2020W1000	Wall mounted humidity transmitter 2% R.H.
VH2020D10000	Duct mounted humidity sensor 2% R.H.
S2000D1000	Duct mounted outside air temperature sensor
S2020E1000	Outside air temperature sensor in a NEMA 4 enclosure
S1010E1000	Outside air temperature sensor, capsule type (¼" dia., 1" long)

VH2020W1000, remote wall mounted room humidity sensor.
(see Fig.8) (wiring diagram next page)

VH2020D1000, remote duct mounted humidity sensor c/w junction box.
(see Fig.9) (wiring diagram next page)

This sensor can be used for:

- Remote return air humidity sensing with the sensor mounted on the return air duct.
- Supply air humidity sensor used as a high limit protection.



Fig.9- VH2020W1000

S2020E1000, commercial style outside air temperature sensor in a NEMA 4 enclosure. (see Fig.10) (wiring diagram next page)

S1010E1000, residential style outside air temperature sensor, capsule type. (see Fig.11) (wiring diagram next page)

- These sensors are used for the humidity setpoint reset function based on outdoor temperature.

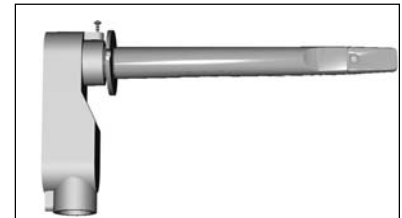

Fig.10 – VH2020D1000 / S2000D1000

INSTALLATION NOTICE !



- If replacing an old humidistat, label the wires before removal of the old humidistat.
- Electronic controls are static sensitive devices. Discharge yourself properly before manipulation and installing the humidistat.
- Short circuit or wrong wiring may permanently damage the humidistat or the equipment.
- Anti-short cycling can be set to 0 minutes for equipment that posses their own anti cycling timer. Do not use that value unless the equipment is equipped with such internal timer. Failure to do so can damage the equipment.
- All VH7200 series humidistat are to be used only as operating controls. Whenever a control failure could lead to personal injury and/or loss of property, it becomes the responsibility of the user to add safety devices and/or alarm system to protect against such catastrophic failures.



Fig.11 – S2020E1000



Fig.12 – S1010E1000

Wiring of humidity and temperature sensors

Wiring example of the High-Limit humidity sensor powered by the same transformer as the VH7200 humidistat

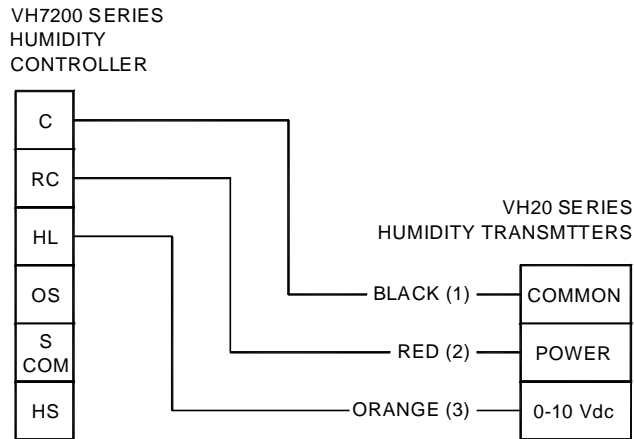

Wiring example of the main remote humidity sensor powered by the same transformer as the VH7200 humidistat

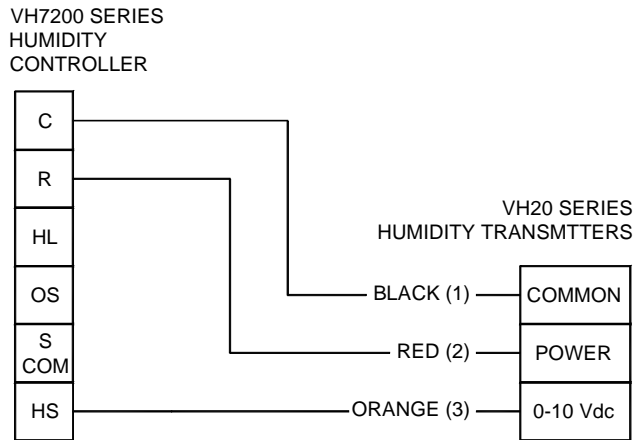

Wiring example of the outside air temperature sensor

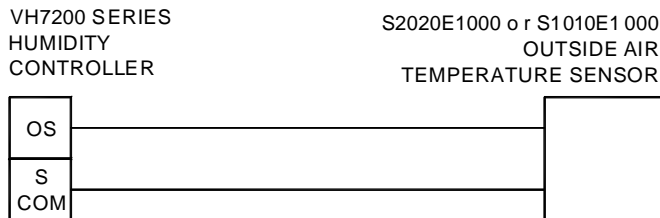

Programming and status display instructions

Status display

The Humidistat features a two-line, eight-character display. There is a low level back-light level that is always active and can only be seen at night.

When left unattended, the Humidistat has an auto scrolling display that shows the actual status of the system. There is an option in the configuration menu to lockout the scrolling display and to only present the room humidity and conditional outdoor humidity to the user. With this option enabled, no local status is given of mode, schedule and relative humidity.

Each item is scrolled one by one with the back lighting off. Pressing any key will cause the back light to come on. When left unattended for 10 seconds after changes are made, the display will resume automatic status display scrolling.

To turn on the back light, press any key on the front panel. The back lit display will turn off when the humidistat is left unattended for 45 seconds.

Sequence of auto-scroll status display:

Humidity	Effective RH Setpoint	System Mode	Outdoor Temperature	Alarms
Humidity xx %RH	RH reset xx %RH	Sys mode off	Outdoor x.x °C or °F	Service
		Sys mode auto		Canister
		Sys mode Humid		
		Sys mode Dehumid		

Humidity

Displayed value is either the internal humidity sensor or will automatically switch to display the value of a remote sensor if one is connected on terminal HS

Effective RH Setpoint

This conditional display prompt will show the actual reset value of the humidification setpoint if:

- The humidistat is not in dehumidification
- The outdoor temperature sensor is connected
- The outdoor temperature humidification setpoint reset function is used
- The outdoor temperature value is below the reset RH higher outside humidity setpoint parameter

System Mode

Displayed and available system modes are dependent on the configured sequence of operation parameter.

	Selected sequence of operation	Modes available	Default mode
0 = Ahu	0-10V Analog humidification only	Off - Humid	Humid
1 = 2Phu	2 position On-Off humidification	Off - Humid	Humid
2 = 2Pdh	2 position On-Off dehumid only	Off - Dehumid	Dehumid
3 = Ahu 2Pdh	Analog humidification & 2 position On-Off dehumidification	Off – Humid – Dehumid - Auto	Auto
4 = 2Phu2Pdh	2 position On-Off humidification & 2 position On-Off dehumidification	Off – Humid – Dehumid - Auto	Auto

Outdoor Temperature

Is displayed only when an outdoor temperature sensor is connected or a valid network value is received.

Alarms

This conditional prompt will display alarms when they are detected

- Alarms will automatically be displayed at the end of the status display scroll.
- During an alarm message display, the back lit screen will light up at the same time as the message and shut off during the rest of the status display scroll.
- Two alarms maximum can appear at any given time. The priority for the alarms is as follows:

Service	Indicates that there is a service alarm as per one of the programmable binary input (BI)
Canister	Indicates that the canister is dirty as per one of the programmable binary input (BI)

Two status LED's on the humidistat cover are used to indicate if Humidification or Dehumidification is active.

- When Humidity output is active the “Hum” LED will illuminate.
- When Dehumidification sequence is active, the “Dehum” LED will illuminate.



Fig.13 – User interface

Installer configuration parameter menu

Configuration can be done through the network or locally at the Humidistat.

- To enter configuration, press and hold the Mode button for 8 seconds
- Press again the mode button repetitively to scroll between all the available parameters
- Use the up and down key to change the parameter to the desired value.
- To acknowledge and save the new value, press the mode button again.
- The next listed parameter is now displayed

Configuration interface

Mode	Enters the configuration mode. Press and hold for 8 seconds Pressing repetitively will scroll all available parameters one by one. Concurrently, the mode button is used to toggle between Humidify and dehumidify set points
Down	Adjust / rotate parameter value down
Up	Adjust / rotate parameter value up

User interface:

The user may choose to scroll between mode of the humidistat. By depressing on the mode button the user may manually toggle between the following modes of operation;

Off	System is disabled
Auto	System will satisfy both Humidification and Dehumidification setpoints
Humidification	System will satisfy the Humidification setpoint only
Dehumidification	System will satisfy Dehumidification setpoint only

Keypad interface:

Mode	The user may choose to scroll between mode of the humidistat. By depressing on the mode button the user may manually toggle between the following modes of operation; While making changes to setpoints in “Auto Mode” the mode button is utilized to toggle between humidify and dehumidify setpoints
Down	Adjust the setpoints down ❖ In Humidification mode only the humidification setpoint is displayed, ❖ In Dehumidification mode only the Dehumidification setpoint displayed ❖ In auto mode, (See below)
Up	Adjust the setpoints up ❖ In Humidification mode only the humidification setpoint is displayed, ❖ In Dehumidification mode only the Dehumidification setpoint displayed ❖ In auto mode, (See below)

1. Lockouts of access to certain functions is made with configuration parameter (lockout)
2. If the supply humidity sensor is used, press both the mode button and the up arrow button simultaneously to momentarily display the supply humidity

High limit display:

Valid only if a high limit 0 to 10 Vdc humidity sensor is used and wired at terminal (HL). The actual value “Duct HL” read by the sensor can be displayed by pressing both the mode and down arrow button simultaneously for a few seconds.

Set point Adjustments

Humidification Mode	Dehumidification Mode	Off Mode	Auto Mode <ul style="list-style-type: none"> Set point presented to user is the set point from the last action taken by the humidistat or the one currently in use. Humidify and Dehumify set points are changed independently by using the toggle function associated with the mode button.
HumXX %	Dehum XX %	Access to setpoint adjustment	Hum XX % and Dehum XX % Both Hum and Dehum set point are changed independently utilizing the mode button to toggle between the two. A fixed dead band of 5% RH is present.

Installer configuration parameter menu

Configuration can be done through the network or locally at the humidistat.

- To enter configuration, press and hold the mode button for 8 seconds**
- Press the same mode button repetitively to scroll between all the available parameters
- Use the up and down key to change the parameter to the desired value.
- To acknowledge and save the new value, press the mode button again.
- The next listed parameter is now displayed

Config. parameters	Significance Default value	Adjustments
Com Addr	Humidistat networking address Default value = 4 Range is: 0 to 254	Conditional parameter to BACnet MS-TP models (VH72xxX1000B) Conditional parameter to Wireless models (VH72xxX1000W) This parameter will only appear when a BACnet or wireless network adapter is present. If the humidistat is installed as a stand-alone unit or with an Echelon adapter, this parameter will not be used or displayed <ul style="list-style-type: none"> For BACnet MS-TP models valid range to use is from 1 to 127 For wireless models valid range is 0 to 254 with a maximum of 30 thermostat per VGG
PAN ID	Personal Area Network Identification Default value = 0 Range is: 0 to 500	Conditional parameter to Wireless models (VH720xxX1000W) This parameter will only appear when a wireless network adapter is present. If the humidistat is installed as a stand-alone unit or with a BACnet or Echelon adapter, this parameter will not be used or displayed This parameter (Personal Area Network Identification) is used to link specific humidistat to a single specific Viconics wireless gateway (VWG) For every humidistat reporting to a gateway (maximum of 30 device per gateway), be sure you set the SAME PAN ID value both at the gateway and the humidistat(s). The default value of 0 is NOT a valid PAN ID. The valid range of available PAN ID is from 1 to 500
Channel	Channel selection Default value = 10 Range is: 10 to 26	Conditional parameter to Wireless models (VT720xx0X1000W) This parameter will only appear when a wireless network adapter is present. If the humidistat is installed as a stand-alone unit or with a BACnet or Echelon adapter, this parameter will not be used or displayed This parameter (Channel) is used to link specific humidistat to specific Viconics wireless gateway(s) (VWG) For every humidistat reporting to a gateway (maximum of 30 device per gateway), be sure you set the SAME channel value both at the gateway and the thermostat(s). Viconics recommends using only the 2 last channels (25-2575MHz and 26-2580MHz) The default value of 10 is NOT a valid channel. The valid range of available channel is from 11 to 26

Config. parameters	Significance Default value	Adjustments
Get From	Get From Reference address Default value=255	Conditional parameter to Wireless models (VH72xxX1000W) This parameter / function is not currently supported by the wireless humidistat
BI 1	Binary input no.1 configuration Default value = None	None , No function will be associated with the input Canister , a back-lit flashing Canister alarm will be displayed on the humidistat LCD screen when the input is energized Service , a back-lit flashing Service alarm will be displayed on the humidistat LCD screen when the input is energized <ul style="list-style-type: none"> • Open contact input = function not energized • Closed contact input = function energized
Lockout	Keypad lockout levels Default value = 0 No lock	0 = No lock 1 = Low level lock
Level		
	Sys Mode	Setpoints
0	Yes access	Yes access
1	No access	No Access
SeqOpera	Sequence of operation Default value is = 2 2 position On-Off dehumid	Sets the desired control operation of the humidistat Available sequence of operation is dependent on humidistat model 0 = Ahu - 0-10V Analog humidification only 1 = 2Phu - 2 position On-Off humidification 2 = 2Pdh - 2 position On-Off dehumid only 3 = Ahu 2Pdh - Analog humidification & 2 position On-Off dehumidification 4 = 2Phu2Pdh - On-Off humidification & 2 position On-Off dehumidification
Units	Sets the display scale of the thermostat Default value = °F	°F for Fahrenheit scale °C for Celsius scale
Humi max	Maximum humidify set point limit Default value = 90 %	Maximum humidity set point adjustment. Humidity set point range is: 10% to 90 %
Dehu min	Minimum dehumidify set point limit Default value = 15%	Minimum Dehumidification set point adjustment. Cooling setpoint range is: 15% to 95%
MenuScro	Menu Scroll Default value = On	This parameter allow the user to select from scrolling system mode, room humidity level. Disabling the scrolling function will render the display with the Room humidity only.
Hum cph	On/Off humidification devices cycles per hour setting: Default value = 4 C.P.H.	Will set the maximum number cycles per hour under normal control operation for the relay humidification output. It represents the maximum number of cycles that the equipment will turn ON and OFF in one hour. Note that a higher C.P.H will represent a higher accuracy of control at the expense of wearing mechanical components faster. 3, 4, 5, 6,7 & 8 C.P.H.
Dhu cph	On/Off dehumidification devices cycles per hour setting: Default value = 4 C.P.H.	Will set the maximum number cycles per hour under normal control operation for the relay dehumidification output. It represents the maximum number of cycles that the equipment will turn ON and OFF in one hour. Note that a higher C.P.H will represent a higher accuracy of control at the expense of wearing mechanical components faster. 3, 4, 5, 6,7 & 8 C.P.H.
hum lock	Humidification outside air temperature lockout Default value = 120 °F (49 °C)	Disables Humidification operation based on outdoor air humidity. Function will only be enabled if OS (outside air humidity sensor) is connected. From -15 °F up to 120 °F (-26 °C up to 49 °C)

Config. parameters	Significance Default value	Adjustments
Dhu OALK	Dehumidification outside air temperature lockout Default value = -40°F (-40°C)	Outside air temperature under which the dehumidification sequence is disabled. Only valid if an outdoor air sensor is connected at the humidistat or a network value is transmitted to the humidistat. From -40°F up to 122°F (-40°C to 50°C)
HL Hyst	High Limit hysteresis Default value = 5% RH	High Limit control hysteresis. Used only if sequence uses 2 position humidity controls 2 = 2Pdh and 4 = 2Phu2Pdh From 2% RH up to 20% RH
cal RH	Humidity sensor calibration Default value = 0 %RH	Offset that can be added/subtracted to actual displayed humidity by ± 15.0 %RH. This calibration applies to the internal humidity sensor if no remote humidity sensor is connected. This calibration applies to the remote humidity sensor when one is connected. From -15% RH up to 15% RH
cal OS	Outside air temperature sensor calibration Default value = 0.0 °F or °C	Offset that can be added/subtracted to the displayed outside air temperature ± 5.0 °F (± 2.5 °C)
RH LT	Reset RH lower outside temperature setpoint Default value = -20°F (-29°C)	Minimum outside air temperature for RH setpoint reset. Only valid if an outdoor air sensor is connected at the humidistat or a network value is transmitted to the humidistat. See RH HT & RE Sp. From -40°F up to 15°F (-40°C to -9.5°C)
RH HT	Reset RH higher outside humidity setpoint Default value = 32°F (0°C)	Maximum outdoor air temperature for RH setpoint reset. Only valid if an outdoor air sensor is connected at the humidistat or a network value is transmitted to the humidistat. See RH LT & RE Sp From 20°F up to 55°F (-6.5°C to 12.5°C)
RE Sp	Reset humidity setpoint Default value = 20% RH	The RH setpoint will be reset from the user setpoint to this value when the RH LT outside air humidity value is reached. Only valid if an outdoor air sensor is connected at the humidistat or a network value is transmitted to the humidistat. See RH LT & RE HT. From 10% RH up to 90% RH
HL Sp	RH High limit setpoint Default value = 85% RH	High humidity limit in the supply. Only valid if a 0-5 Vdc sensor is connected at the humidistat – otherwise this feature is disabled automatically. From 50% RH up to 90% RH

Humidity setpoint reset by outside air temperature

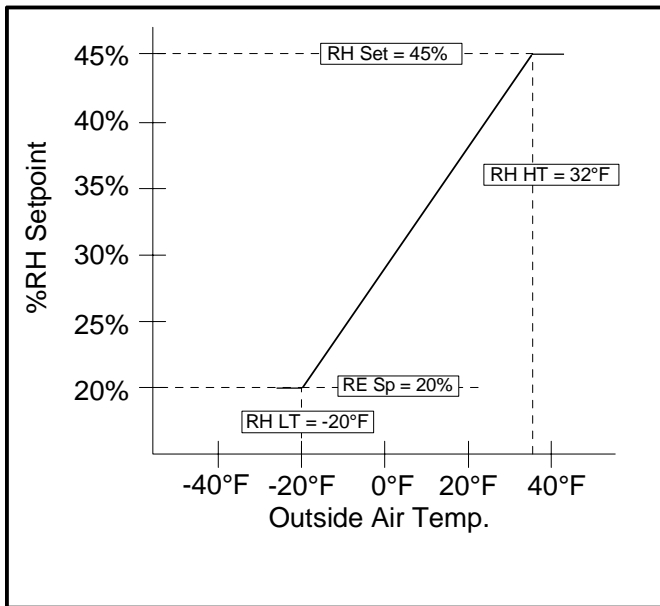

If an outdoor air sensor is connected at the thermostat or a value is received from the network, it can be used to reset the humidity setpoint during the cold season to minimize condensation on windows and building structures.

When the outdoor temperature falls below the selected high temperature, parameter **RH HT** (32°F in the example Figure 8), the humidity setpoint will start to decrease. The lowest humidity setpoint will be reached at selected low temperature, parameter **RH LT** (-20°F).

The setpoint decrease from original setpoint to the lowest setpoint determined by the parameter **RE Sp**. In the example, Figure 8, **RE Sp** was set to 20%, therefore the humidity setpoint dropped from 45% to 20%.

If you don't want to use this feature, set the **RE Sp** parameter to 90% RH.

Fig.11 – Humidity setpoint reset by outside air temperature

High limit humidity sensor (VH7270 Models Only)

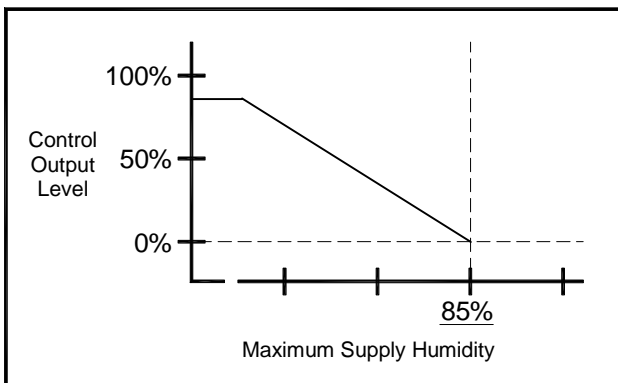

The VH7270 models include a high limit sequence. This allows the use of a remote 0 to 10 Vdc humidity sensor to limit the humidity in the supply air. If no sensor is detected at the HL connector, this sequence is disabled at the humidistat.

Note: this high limit function is not a safety device. For critical situations, provide installation with normal protections required to ensure a safe operation.

Fig.12 – High humidity limit vs Control output level curve

Troubleshooting guide

Symptom	Possible Cause	Corrective Action
Digital display shows missing digits or erratic segments	Defective display	Replace humidistat
Humidistat does not call for humidification. (Hum LED is OFF)	RH sensor is out of range	Verify the remote RH sensor or the internal RH sensor
	System Mode in Dehumidification or Off	Change the system mode parameter to Humidification
	System Mode in Auto but there is a Dehumidification demand at the humidistat	Wait: when a Humidification demand will occur at the humidistat, humidification will resume
	High limit sensor is controlling the humidifier output by forcing it to 0%	Wait: when the supply humidity will drop below the high limit setpoint, humidification will resume.

Humidistat calls for humidification. (Hum LED is ON) but the humidifier does not operate	On a VH7270F1000, disconnect the wire on the "Hum" terminal measure the voltage across terminals "Hum" and "C" you should read a dc voltage close to 10 Volts	If the "Hum" LED is ON and you measure a dc voltage close to 10 Vdc, the humidistat is working fine. Look at the wiring between the Humidistat and the Humidifier. If the Humidistat is not powered by the Humidifier (separate transformer) you may have a conflict with the Common (signal reference)
		If the "Hum" LED is ON and you don't measure a dc voltage, the humidistat is probably defective, contact your distributor or Viconics technical support department.
	On a VH7200A1000, disconnect the wire on the "Hum" terminal measure the voltage across terminals "Hum" and "C" you should read 24 Vac.	If the "Hum" LED is ON and you measure 24 Vac, the humidistat is working fine. Look at the wiring between the Humidistat and the Humidifier. If the Humidistat is not powered by the Humidifier (separate transformer) you may have a conflict with the Common (signal reference)
		If the "Hum" LED is ON and you don't measure 24 Vac, the humidistat is probably defective, contact your distributor or Viconics technical support department.
Humidistat does not call for dehumidification (Dehum LED is OFF)	RH sensor is out of range	Verify the remote humidity sensor and it's wiring or the internal RH sensor
	System Mode in Humidification or Off	Change the system mode parameter to Dehumidification
	System Mode in Auto but there is a Humidification demand at the humidistat	Wait: when a Dehumidification demand will occur at the humidistat, dehumidification will resume.
	Outside air humidity is below the Dhu OALK parameter	Change the Dhu OALK parameter to a value that will enable the dehumidification, if desired.
Humidistat calls for dehumidification (Dehum LED is ON) but the dehumidifier does not operate	On all models, take a wire (jumper) and short across "DEH" and "DEH" terminals.	When you short across the two "DEH" terminals the unit does not operate, the problem is related to wiring or to the dehumidification device. Refer to wiring diagram.
		If the system turns ON when you short across the two "DEH" terminals the humidistat dehumidification contact is probably defective, replace humidistat.

Specifications

Humidistat power requirements:	19-30 Vac 50 or 60 Hz; 2 VA (RC & C) Class 2
Operating conditions:	0 °C to 50 °C (32 °F to 122 °F) 0% to 95% R.H. non-condensing
Storage conditions:	-30 °C to 50 °C (-22 °F to 122 °F) 0% to 95% R.H. non-condensing
Resolution:	Temperature: ± 0.1 °C (± 0.2 °F) Humidity: ± 0.1%
Control accuracy:	Humidity: ± 5% RH from 20 to 100% RH at 50 to 90°F (10 to 32°C)
Humidification setpoint range:	10% RH to 90% RH
Dehumidification setpoint range:	15% RH to 95% RH
Outdoor air temperature range:	-40 °C to 50 °C (-40 °F to 122 °F)
Binary inputs:	Relay dry contact only across "Scm" and "DI1" terminals
Contact output rating:	Each relay output: 30 Vac, 1 Amp. Max. / 30 Vac, 3 Amp. in-rush
Analog output rating	0 to 10 Vdc into 2KΩ resistance minimum
Wire gauge	18 gauge maximum, 22 gauge recommended
Dimensions:	4.94" x 3.38" x 1.13"
Approximate shipping weight:	0.75 lb (0.34 kg)

Agency Approvals:

UL	UL 873 (US) and CSA C22.2 No. 24 (Canada), File E27734 with CCN XAPX (US) and XAPX7 (Canada)
FCC	Compliant to CFR 47, Part 15, Subpart B, Class A (US)
Industry Canada	ICES-003 (Canada)
CE	EMC Directive 89/336/EEC (Europe Union)
C-Tick	AS/NZS CISPR 22 Compliant (Australia / New Zealand)

Drawing & dimensions

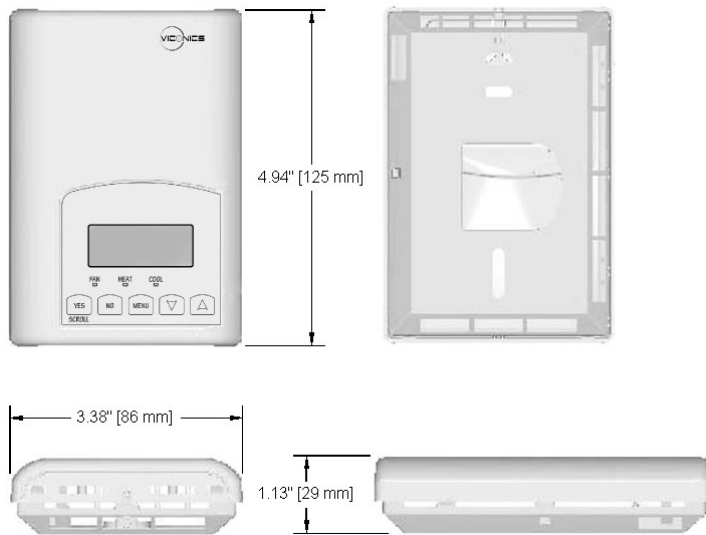

Important notice



All VH7200 series controls are for use as operating controls only and are not safety devices. These instruments have undergone rigorous tests and verifications prior to shipment to ensure proper and reliable operation in the field. Whenever a control failure could lead to personal injury and/or loss of property, it becomes the responsibility of the user / installer / electrical system designer to incorporate safety devices (such as relays, flow switch, thermal protections, etc...) and/or alarm system to protect the entire system against such catastrophic failures. Tampering of the devices or miss application of the device will void warranty.

Fig.16 – Humidistat dimensions : VH7200A1000, VH7270F1000, VH7270K1000

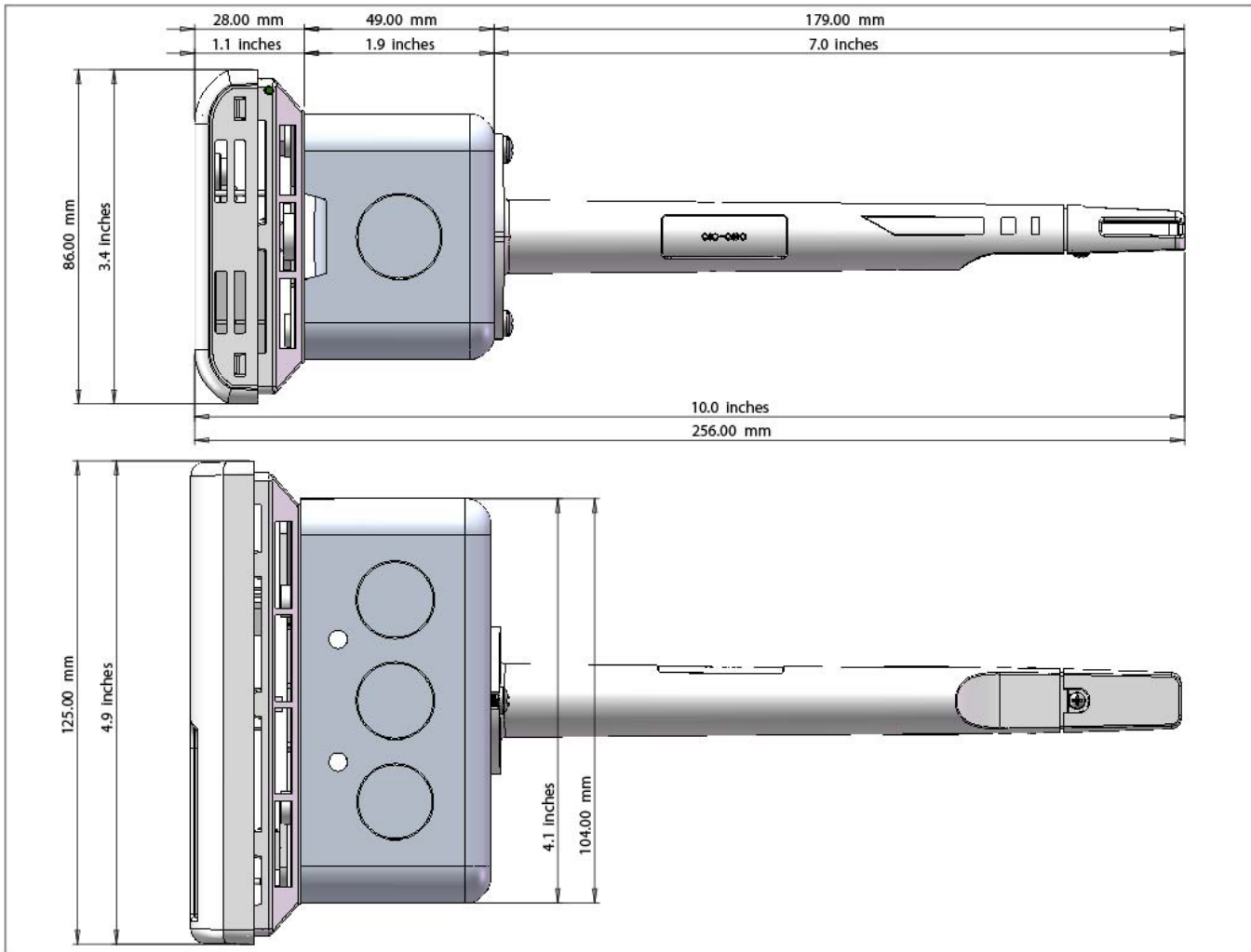

Fig.17 – Humidistat dimensions : VH7270D1000