

VG2000 Series Cast Iron Flanged Globe Valves

Installation Instructions

Part No. 14-1161-106, Rev. B

Issued June 15, 2007

Supersedes November 15, 2002

Applications

VG2000 Series Cast Iron Flanged Globe Valves are primarily designed to regulate the flow of water, 50% glycol solutions, and steam in response to the demand of a controller in Heating, Ventilating, and Air Conditioning (HVAC) systems. VG2000 Series Cast Iron Flanged Globe Valves feature brass trim and are available in two-way Push-Down-To-Close ([PDTTC] – normally open if pneumatically actuated) or Push-Down-To-Open ([PDTO] – normally closed if pneumatically actuated) and three-way mixing configurations. These iron valves can be ordered with MP8000 Series pneumatic actuators (with or without a pneumatic or electro-pneumatic positioner). VG2000 can also be ordered with any of the following series of electric actuators: M9116, M9124, M9220, VA-310x, or VA-610x. The valves can also be ordered separately for field mounting of all of these actuators and the M100 Series of electric actuators with the use of standardized mounting kits.

The modulating valve plug of VG2000 Series valves provides a modified linear flow characteristic. An arrow is cast on both sides of the valve body indicating the direction of flow for proper piping.

Contact the local Johnson Controls® representative for compatibility concerns before using the VG2000 Series flanged valves to control fluids other than those outlined in the *Technical Specifications* table at the end of this document.

Location of Valve Data

Each VG2000 Series Cast Iron Flanged Globe Valve shipped from the factory includes a brass tag chained to the valve bonnet that features technical data about the valve. The technical data on the tag includes:

- the code number of the valve
- the flow coefficient Cv of the valve
- the manufacturing date code of the valve

IMPORTANT: The VG2000 Series Valves are intended to control saturated steam, hot water, and chilled water flow under normal equipment operating conditions. Where failure or malfunction of the VG2000 Series Valve could lead to personal injury or property damage to the controlled equipment or other property, additional precautions must be designed into the system. Incorporate and maintain other devices such as supervisory or alarm systems or safety or limit controls intended to warn of, or protect against, failure or malfunction of the VG2000 Series Valve.

Installation

Install the VG2000 Cast Iron Flanged Globe Valve with actuator at or above the centerline of the piping.

IMPORTANT: Take care to prevent foreign material such as weld slag, thread burrs, metal chips, and scale from entering the piping system. This debris can damage or severely impede the operation of the valve by embedding itself in the seats, scoring the valve, and ultimately resulting in seat leakage. If the debris becomes embedded in the seats, subsequent flushing and filtering of the piping system with the valve installed does not remedy the problem.

For more detailed installation information about the specific equipment used, refer to the appropriate document from the following list:

- *M9108, M9116, M9124, and M9132 Series Electric Non-Spring Return Actuators Installation Instructions (Part No. 34-636-399)*
- *M9220-AGx-3 Floating Electric Spring Return Actuators Installation Instructions (Part No. 34-636-1689)*
- *M9220-Bxx-3 On/Off Electric Spring Return Actuators Installation Instructions (Part No. 34-636-1239)*
- *M9220-GGx-3 Proportional Electric Spring Return Actuators Installation Instructions (Part No. 34-636-1697)*

- *M9000-53x Cast Iron Flanged Valve Linkage Kit for Mounting a Single M9000 Series Electric Actuator Installation Instructions (Part No. 14-1298-18)*
- *M9000-53x Cast Iron Flanged Valve Linkage Kit for Tandem Mounting of M9000 Series Electric Actuators Installation Instructions (Part No. 14-1298-26)*
- *VA-3100 Series Electric Valve Actuators Installation Instructions (Part No. 14-1233-5)*
- *VA-6100 Series Electric Valve Actuators Installation Instructions (Part No. 14-1234-18)*
- *M100A Series On-Off/Floating Control Actuator Installation Bulletin (LIT-2681292)*
- *M100G Series Proportional Actuator with VDC/mA Control Input R81GAA-2 Interface Board Installation Bulletin (LIT-2681298)*
- *MP8000 Series Pneumatic Valve Actuators Technical Bulletin (LIT-977258)*
- *MP8000 Series Actuated Valves with V-9502-95 Pneumatic Valve Actuator Positioner Installation Instructions (Part No. 14-1161-68)*
- *EPP-1000 Series Electro-Pneumatic Positioners Installation Bulletin (LIT-2681275)*

Dimensions

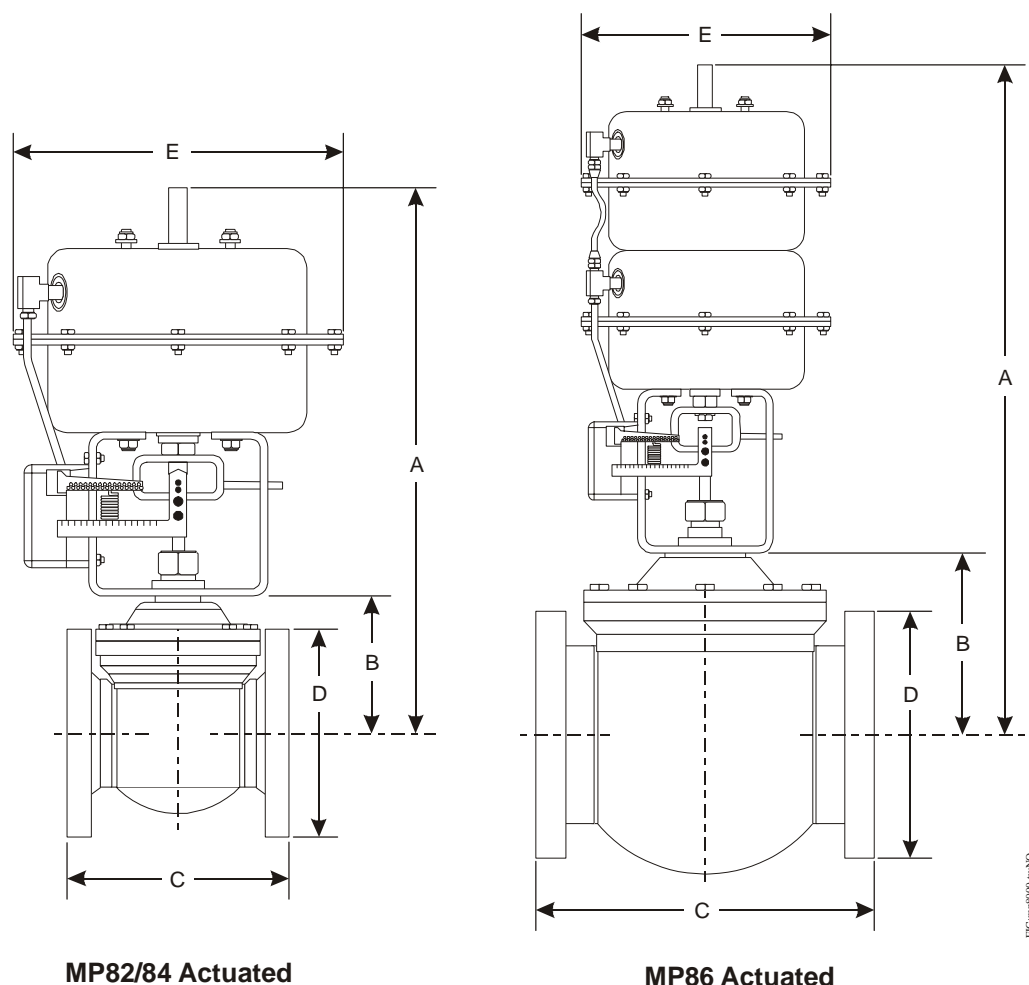
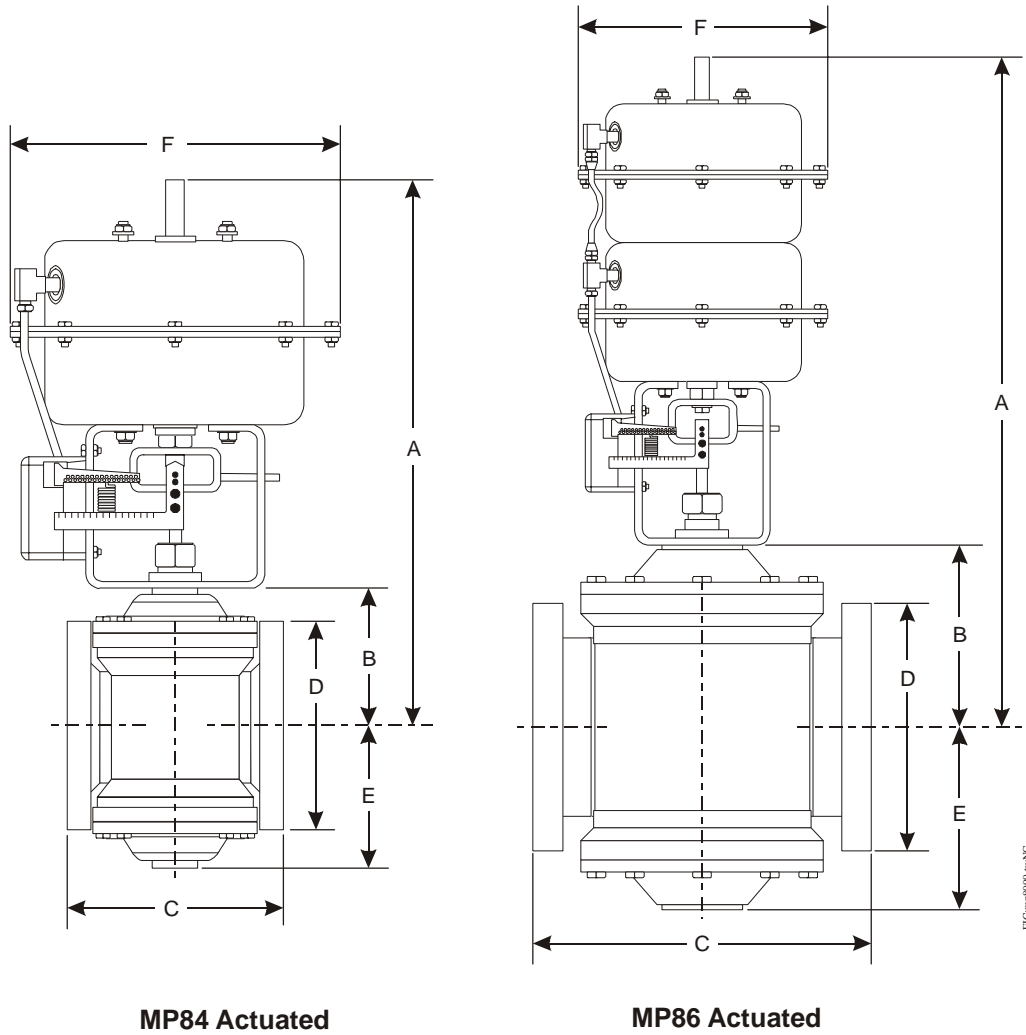

**Figure 1: Dimensions for MP8000 Actuated Two-Way N.O. Valve
(See Table 1.)**

Table 1: MP8000 Actuated Two-Way N.O. Valve Dimensions, in. (mm)

Actuator Style ¹	Valve Size in.	A	B	C	D	E
MP82	2-1/2	15-3/16 (386)	4-21/32 (118)	7-1/4 (184)	7 (178)	8-21/32 (220)
	3	15-13/16 (402)	5-3/16 (132)	8-5/8 (219)	7-1/2 (191)	8-21/32 (220)
MP84	2-1/2	18-17/32 (471)	4-21/32 (118)	7-1/4 (184)	7 (178)	10-7/8 (276)
	3	19-3/16 (487)	5-5/16 (135)	8-5/8 (219)	7-1/2 (191)	10-7/8 (276)
	4	20-5/16 (516)	6-7/16 (164)	10-1/2 (267)	9 (229)	10-7/8 (276)
MP86	3	27-1/4 (692)	5-5/16 (135)	8-5/8 (219)	7-1/2 (191)	10-7/8 (276)
	4	28-3/8 (721)	6-7/16 (164)	10-1/2 (267)	9 (229)	10-7/8 (276)
	5	28-13/16 (732)	6-7/8 (175)	12-1/2 (318)	10 (254)	10-7/8 (276)
	6	30-1/8 (765)	8-3/16 (208)	14-1/2 (368)	11 (279)	10-7/8 (276)

1. Allow 3-3/4 in. (95 mm) clearance for MP82/MP84 actuator removal and 4-3/4 in. (121 mm) clearance for MP86 actuator removal.

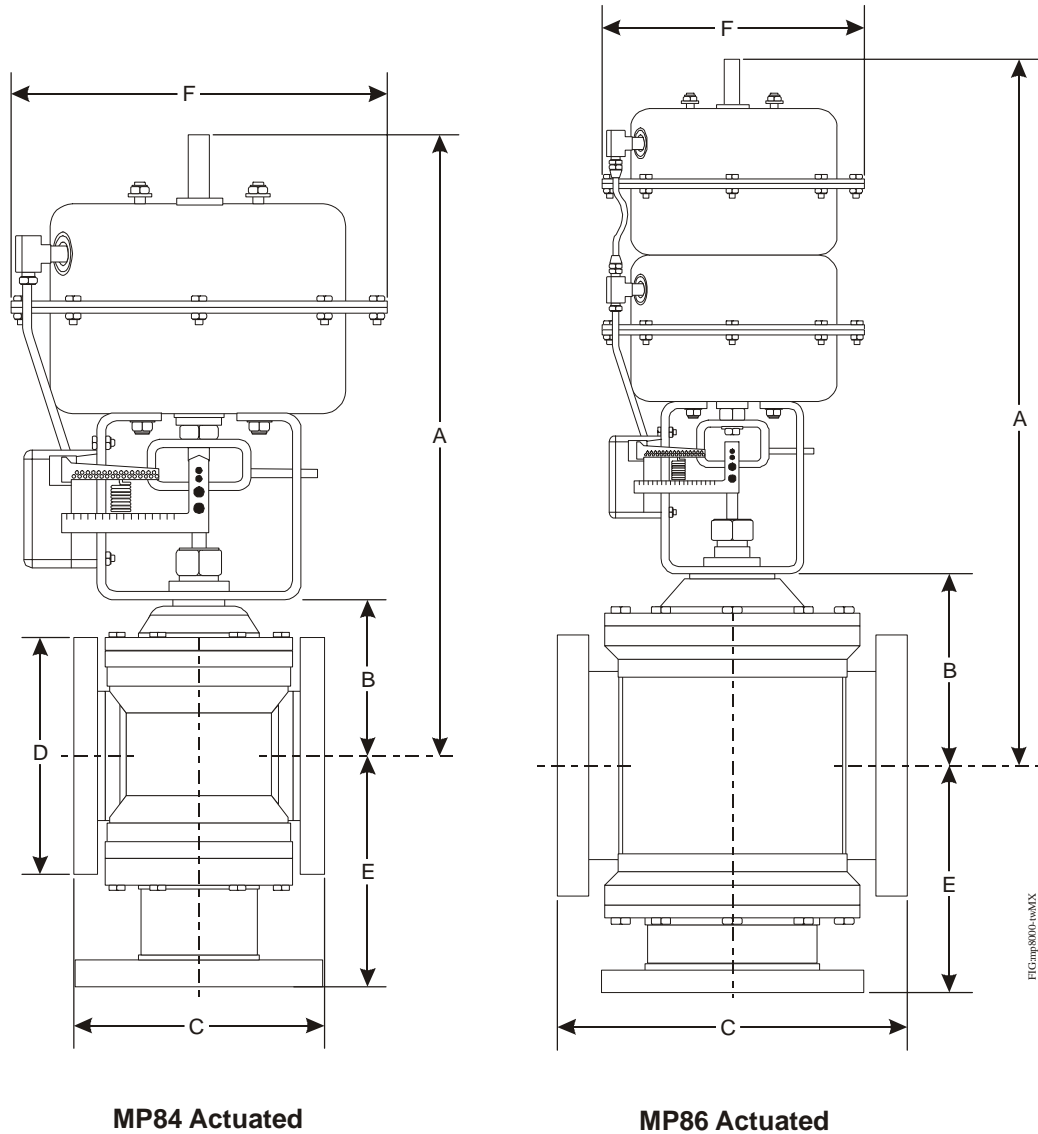

**Figure 2: MP8000 Actuated Two-Way N.C. Valve Dimensions
(See Table 2.)**

Table 2: Pneumatic Actuated N.C. Valve Dimensions, in. (mm)

Actuator Style ¹	Valve Size in.	A	B	C	D	E	F
MP84	2-1/2	18-17/32 (471)	4-21/32 (118)	7-1/4 (184)	7 (178)	4-21/32 (118)	10-7/8 (276)
	3	19-3/16 (487)	5-5/16 (135)	8-5/8 (219)	7-1/2 (191)	5-5/16 (135)	10-7/8 (276)
	4	20-5/16 (516)	6-1/16 (152)	10-1/2 (267)	9 (229)	6-1/16 (152)	10-7/8 (276)
MP86	3	27-1/4 (692)	5-5/16 (135)	8-5/8 (219)	7-1/2 (191)	5-5/16 (135)	10-7/8 (276)
	4	28-3/8 (721)	6-7/16 (164)	10-1/2 (267)	9 (229)	6-7/16 (164)	10-7/8 (276)
	5	28-13/16 (732)	6-7/8 (175)	12-1/2 (318)	10 (254)	6-7/8 (175)	10-7/8 (276)
	6	30-1/8 (765)	8-3/16 (208)	14-1/2 (368)	11 (279)	8-3/16 (208)	10-7/8 (276)

1. Allow 3-3/4 in. (95 mm) clearance for MP82/MP84 actuator removal and 4-3/4 in. (121 mm) clearance for MP86 actuator removal.

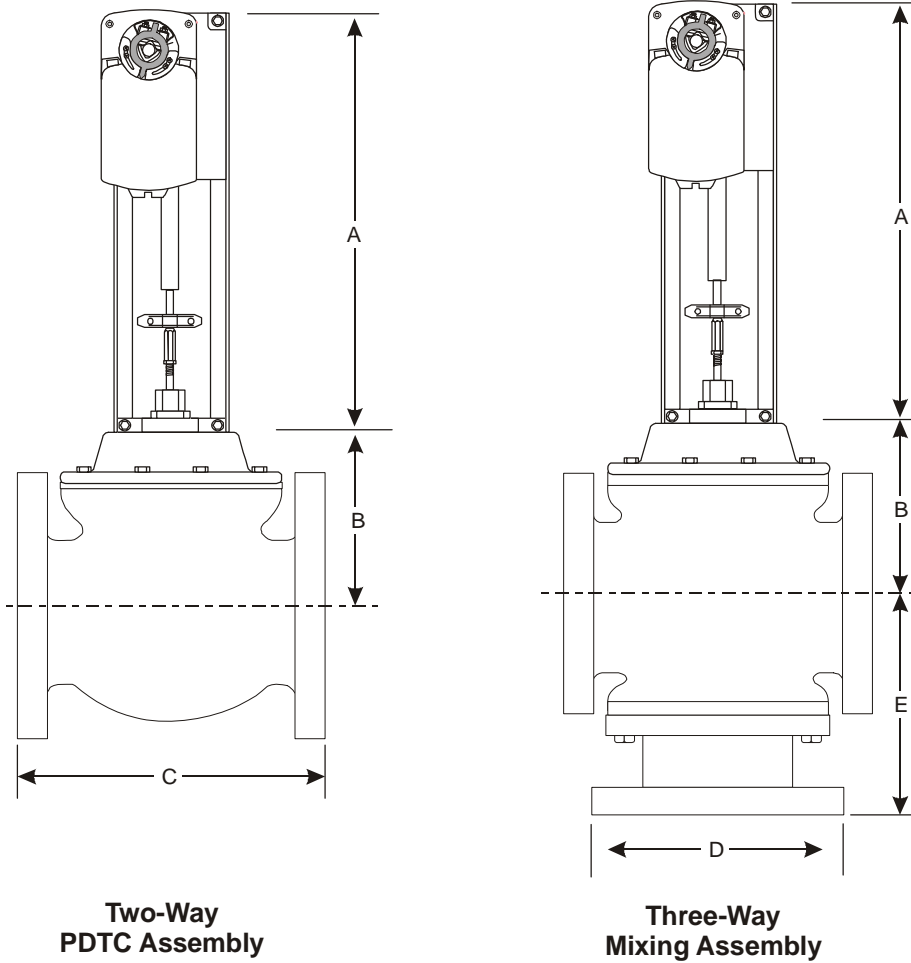

**Figure 3: MP8000 Actuated Three-Way Mixing Valve Dimensions
(See Table 3.)**

Table 3: MP8000 Actuated 3-Way Valve Dimensions, in. (mm)

Actuator Style ¹	Valve Size in.	A	B	C	D	E	F
MP84	2-1/2	18-17/32 (471)	4-21/32 (118)	7-1/4 (184)	7 (178)	6-25/32 (172)	10-7/8 (276)
	3	19-3/16 (487)	5-5/16 (135)	8-5/8 (219)	7-1/2 (191)	6-13/16 (173)	10-7/8 (276)
MP86	3	27-1/4 (692)	5-5/16 (135)	8-5/8 (219)	7-1/2 (191)	6-13/16 (175)	10-7/8 (276)
	4	28-3/8 (721)	6-7/16 (164)	10-1/2 (267)	9 (229)	8-1/16 (205)	10-7/8 (276)
	5	28-13/16 (732)	6-7/8 (175)	12-1/2 (318)	10 (254)	9-5/32 (233)	10-7/8 (276)
	6	30-1/8 (765)	8-3/16 (208)	14-1/2 (368)	11 (279)	9-15/16 (252)	10-7/8 (276)

1. Allow 3-3/4 in. (95 mm) clearance for MP82/MP84 actuator removal and 4-3/4 in. (121 mm) clearance for MP86 actuator removal.



**Figure 4: M9000 Actuated Valve Dimensions, in. (mm)
(See Table 4.)**

Table 4: M9000 Actuated VG2000 Series Cast Iron Flanged Valve Dimensions, in. (mm)

Actuator Style	Valve Size in.	A	B	C	D	E
M9000	2-1/2	16-13/16 (427)	4-21/32 (118)	7-1/4 (184)	7 (178)	6-25/32 (172)
	3	16-13/16 (427)	5-5/16 (135)	8-5/8 (219)	7-1/2 (191)	6-13/16 (175)
	4	16-13/16 (427)	6-7/16 (164)	10-1/2 (267)	9 (229)	8-1/16 (205)
	5	17-3/8 (441)	6-7/8 (175)	12-1/2 (318)	10 (254)	9-5/32 (233)
	6	17-3/8 (441)	8-3/16 (208)	14-1/2 (368)	11 (279)	9-15/16 (252)

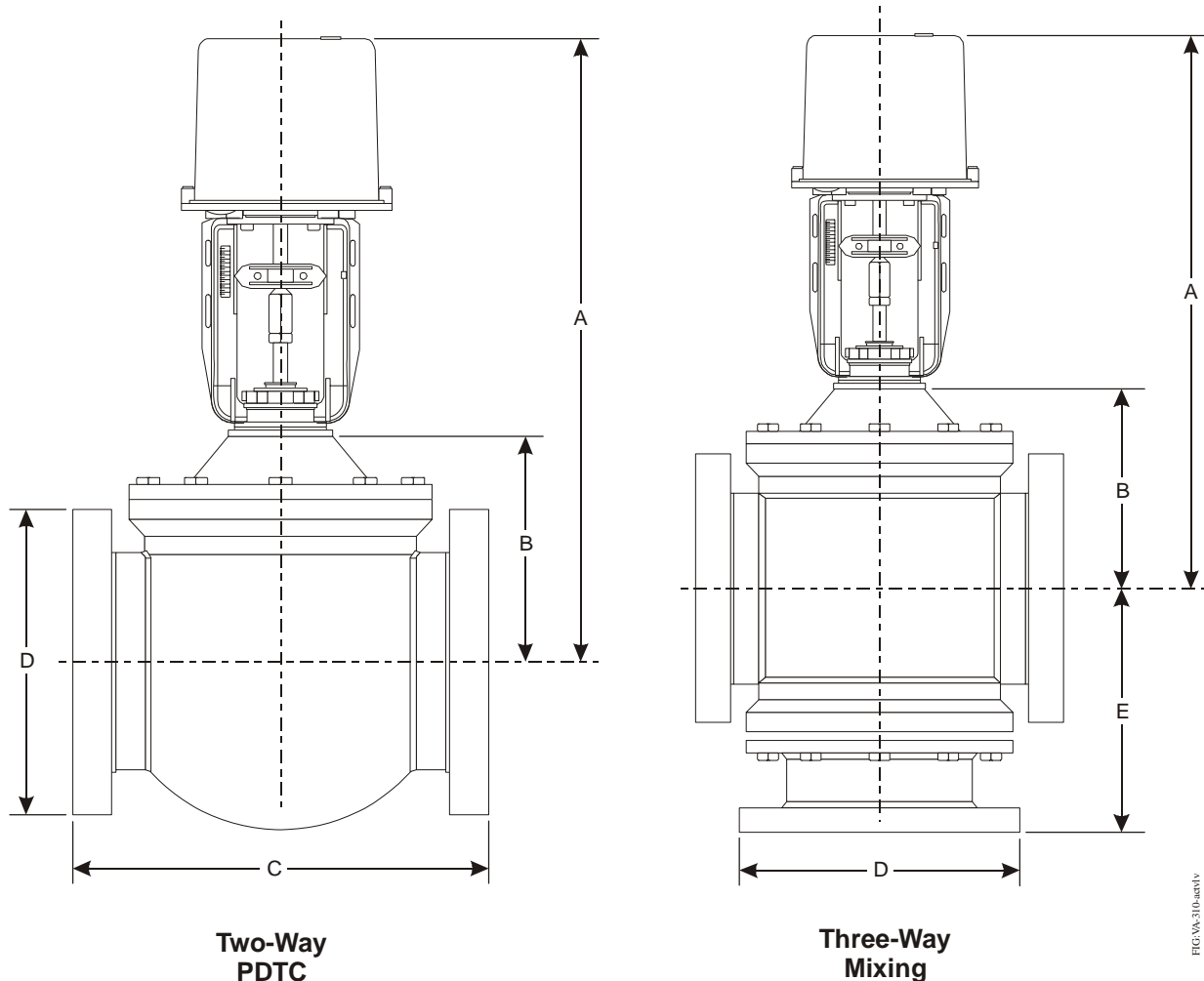
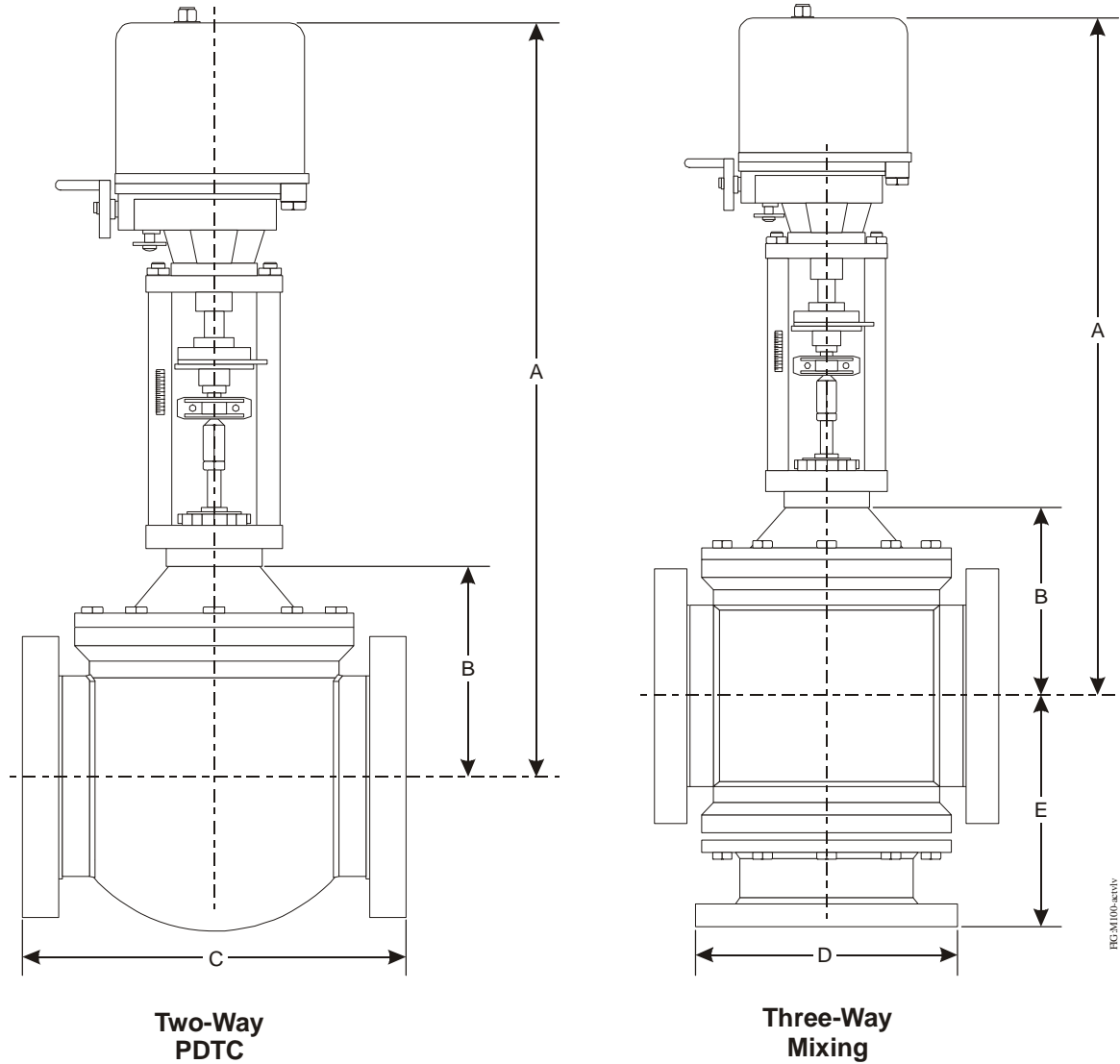

**Figure 5: VA-310x Actuated Valve Dimensions
(See Table 5.)**

Table 5: VA-3100 Actuated Valve Dimensions, in. (mm)

Actuator Style ¹	Valve Size in.	A	B	C	D	E
VA-3100	2-1/2	18-23/32 (475)	4-21/32 (118)	7-1/4 (184)	7 (178)	6-25/32 (172)
	3	19-3/8 (492)	5-5/16 (135)	8-5/8 (219)	7-1/2 (191)	6-13/16 (175)
	4	20-1/2 (521)	6-7/16 (164)	10-1/2 (267)	9 (229)	8-1/16 (205)
	5	20-15/16 (532)	6-7/8 (175)	12-1/2 (318)	10 (254)	9-5/32 (233)
	6	22-1/4 (565)	8-3/16 (208)	14-1/2 (368)	11 (279)	9-15/16 (252)

1. Allow 6-5/16 in. (160 mm) clearance for VA-310x actuator removal.

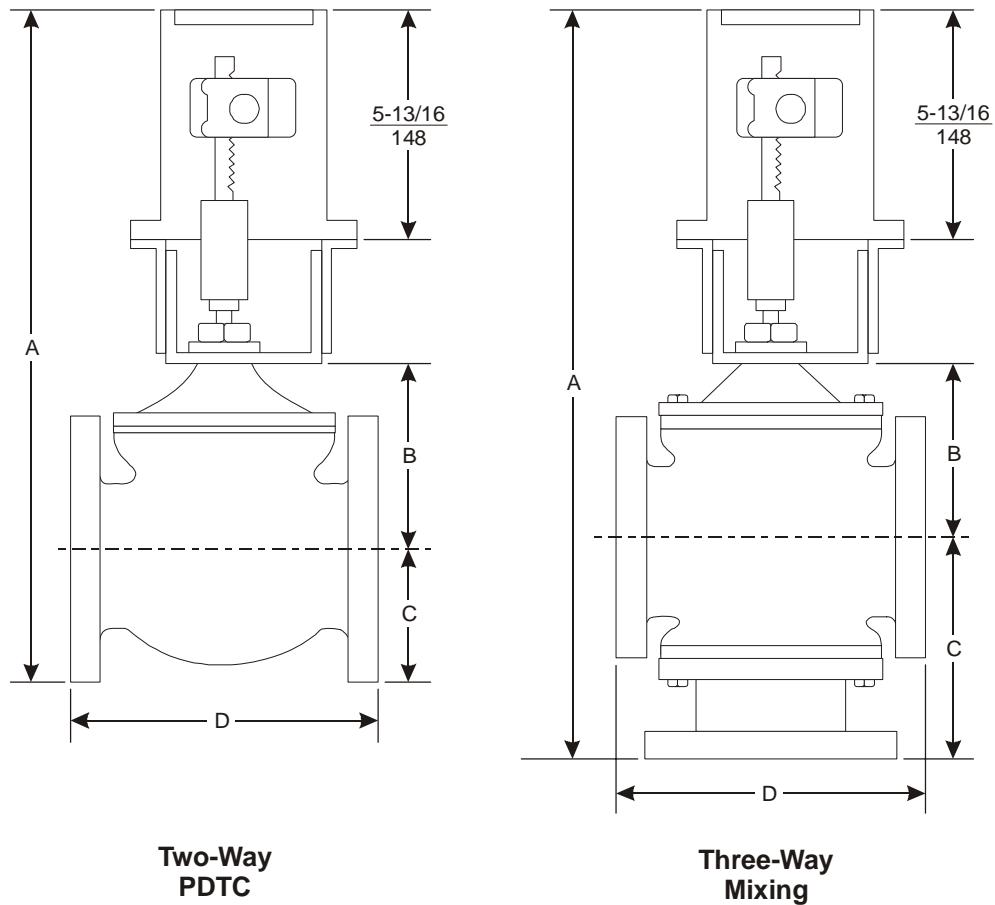

**Figure 6: VA-610x Actuated Valve Dimensions
(See Table 6.)**

Table 6: VA-6100 Actuated Valve Dimensions, in. (mm)

Actuator Style ¹	Valve Size in.	A	B	C	D	E
VA-6100	4	27-21/32 (702)	6-7/16 (164)	10-1/2 (267)	9 (229)	8-1/16 (205)
	5	28-3/32 (714)	6-7/8 (175)	12-1/2 (318)	10 (254)	9-5/32 (233)
	6	29-13/32 (747)	8-3/16 (208)	14-1/2 (368)	11 (279)	9-15/16 (252)

1. Allow 7-29/32 in. (201 mm) clearance for VA-610x actuator removal.



FIGM100-act-h

**Figure 7: M100 Actuated Valve Dimensions
(See Table 7.)**

Table 7: M100 Actuated Valve Dimensions, in. (mm)¹

Valve Style	Valve Size in.	A	B	C	D
Two-Way PDTC	2-1/2	18-1/4 (464)	4-21/32 (118)	3-1/2 (89)	7-1/4 (184)
	3	19-1/8 (486)	5-5/16 (135)	3-3/4 (95)	8-5/8 (219)
	4	20-7/8 (530)	6-7/16 (164)	4-1/2 (114)	10-1/2 (267)
Three-Way Mixing	2-1/2	21-3/4 (552)	4-21/32 (118)	6-13/16 (173)	7-1/4 (184)
	3	22-1/8 (562)	5-5/16 (135)	6-13/16 (173)	8-5/8 (219)
	4	24-7/16 (621)	6-7/16 (164)	8-5/16 (211)	10-1/2 (267)

1. M100 Series Actuators are not available factory mounted.

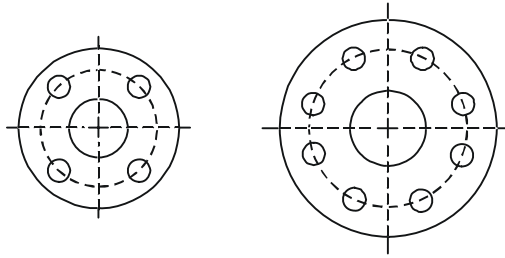

FIGURE

Figure 8: Flange and Bolt Circle

Table 8: Flange and Bolt Circle Dimensions, in. (mm)

Valve Size in.	Diameter of Flange	Thickness of Flange	Diameter of Bolt Circle	Diameter of Bolt Holes	Number of Bolt Holes
2-1/2	7 (178)	11/16 (17)	5-1/2 (140)	3/4 (19)	4
3	7-1/2 (191)	3/4 (19)	6 (152)	3/4 (19)	4
4	9 (229)	1 (25)	7-1/2 (191)	3/4 (19)	8
5	10 (254)	1 (25)	8-1/2 (216)	7/8 (22)	8
6	11 (279)	1 (25)	9-1/2 (241)	7/8 (22)	8

Mounting

Location Considerations

IMPORTANT: Protect the actuator from dripping water, condensation, and other moisture. Water or moisture could result in an electrical short, which may damage or affect the operation of the actuator.

IMPORTANT: Do not cover the actuator with thermal insulating material. High ambient temperatures may damage the actuator, and a hot water pipe, a steam pipe, or other heat source may overheat it.

Wiring

Be sure to wire the input lines to the electric actuator correctly in order for the valve to move in the proper direction.

IMPORTANT: Use copper conductors only. Make all wiring connections in accordance with local, national, and regional regulations. Do not exceed the actuator's electrical ratings.



WARNING: Risk of Electric Shock.

Disconnect the power supply before making electrical connections. Contact with components carrying hazardous voltage can cause electric shock and may result in severe personal injury or death.



CAUTION: Risk of Property Damage.

Do not apply power to the system before checking all wiring connections. Short circuited or improperly connected wires may result in permanent damage to the equipment.

Accessories

Accessories available for the VG2000 Series Valves are listed in Table 9. See Table 10 for a list of available reconditioning kits.

Troubleshooting

Servicing the Actuator or Piping System

When servicing the electric actuator or the piping system:

- disconnect the power supply to the electric actuator or the input line to the pneumatic actuator

- relieve the pressure in the piping system
- follow applicable electrical code requirements when reconnecting wiring to the actuator
- pipe the valve with the flow in the direction of the arrow on the valve body so that the plug seats against the flow

Repair Information

If the VG2000 Series Cast Iron Flanged Globe Valve fails to operate within its specifications, replace the unit. For a replacement valve, contact the nearest Johnson Controls representative.

Table 9: Maintenance Parts (Ordered Separately)

Code Number	Description
V-9999-613	Packing Kits for 3/8 in. Stem (2-1/2, 3, or 4 in. Valves) Kit Includes: two ring packs (U-cup with installed O-ring), one follower, one spacer insertion/removal tool, one grease tube, and one 3 in. (76 mm) strip of crocus cloth
V-5252-668	Packing Kits for 1/2 in. Stem (3, 4, 5 or 6 in. Valves) Kit Includes: two ring packs (U-cup with installed O-ring), one follower, one spacer insertion/removal tool, one grease tube, and one 3 in. (76 mm) strip of crocus cloth
Packing Nut Kits (Pneumatically Actuated Assemblies Only)	
V-4510-6019	Packing Nut for 3/8 in. Stem (2-1/2, 3, or 4 in. Valves)
V-5252-609	Packing Nut for 1/2 in. Stem (3, 4, 5 or 6 in. Valves)

Table 10: Ordering Data - VG2000 Series Reconditioning Kits (Part 1 of 3)

Code Number	Description	Shipping Weight, lb (kg)
V-5252-6001	Reconditioning Kit, 2-1/2 in. N.O. Flanged Valve, 3/8 in. Stem Type "M" for use with MP84 Pneumatic Actuator or Electric Actuator, Cv = 51.0; Includes Bonnet and Packing Items, Stem and Disk Assembly, Packing Tools, Gasket and Screw Set, and Grease Packet	7.0 (3.2)
V-5252-6002	Reconditioning Kit, 2-1/2 in. N.O. Flanged Valve, 3/8 in. Stem Type "L" for use with MP82 Pneumatic Actuator, Cv = 51.0; Includes Bonnet and Packing Items, Stem and Disk Assembly, Packing Tools, Gasket and Screw Set, and Grease Packet	6.9 (3.1)
V-5252-6003	Reconditioning Kit, 3 in. N.O. Flanged Valve, 3/8 in. Stem Type "M" for use with MP84 Pneumatic Actuator or Electric Actuator, Cv = 80.0; Includes Bonnet and Packing Items, Stem and Disk Assembly, Packing Tools, Gasket and Screw Set, and Grease Packet	9.5 (4.3)
V-5252-6004	Reconditioning Kit, 3 in. N.O. Flanged Valve, 3/8 in. Stem Type "L" for use with MP82 Pneumatic Actuator, Cv = 80.0; Includes Bonnet and Packing Items, Stem and Disk Assembly, Packing Tools, Gasket and Screw Set, and Grease Packet	9.5 (4.3)
V-5252-6005	Reconditioning Kit, 4 in. N.O. Flanged Valve, 3/8 in. Stem Type "M" for use with MP84 Pneumatic Actuator or Electric Actuator, Cv = 150.0; Includes Bonnet and Packing Items, Stem and Disk Assembly, Packing Tools, Gasket and Screw Set, and Grease Packet	15.0 (6.8)
V-5252-6006	Reconditioning Kit, 4 in. N.O. Flanged Valve, 1/2 in. Stem Type "N" for use with MP86 Pneumatic Actuator, Cv = 150.0; Includes Bonnet and Packing Items, Stem and Disk Assembly, Packing Tools, Gasket and Screw Set, and Grease Packet	16.5 (7.5)

Table 10: Ordering Data - VG2000 Series Reconditioning Kits (Part 2 of 3)

Code Number	Description	Shipping Weight, lb (kg)
V-5252-6007	Reconditioning Kit, 5 in. N.O. Flanged Valve, 1/2 in. Stem Type "N" for use with MP86 Pneumatic Actuator, Cv = 237.0; Includes Bonnet and Packing Items, Stem and Disk Assembly, Packing Assembly Tool, Gasket and Screw Set, and Grease Packet	22.0 (10.0)
V-5252-6008	Reconditioning Kit, 6 in. N.O. Flanged Valve, 1/2 in. Stem Type "N" for use with MP86 Pneumatic Actuator, Cv = 344.0; Includes Bonnet and Packing Items, Stem and Disk Assembly, Packing Assembly Tool, Gasket and Screw Set, and Grease Packet	30.6 (13.9)
V-5462-6001	Reconditioning Kit, 2-1/2 in. N.C. Flanged Valve, 3/8 in. Stem Type "M" for use with MP84 Pneumatic Actuator or Electric Actuator, Cv = 51.0; Includes Bonnet and Packing Items, Stem and Disk Assembly, Packing Tools, Gasket and Screw Set, and Grease Packet	7.4 (3.4)
V-5462-6002	Reconditioning Kit, 3 in. N.C. Flanged Valve, 3/8 in. Stem Type "M" for use with MP84 Pneumatic Actuator or Electric Actuator, Cv = 80.0; Includes Bonnet and Packing Items, Stem and Disk Assembly, Packing Tools, Gasket and Screw Set, and Grease Packet	9.9 (4.5)
V-5462-6003	Reconditioning Kit, 3 in. N.C. Flanged Valve, 1/2 in. Stem Type "N" for use with MP86 Pneumatic Actuator, Cv = 80.0; Includes Bonnet and Packing Items, Stem and Disk Assembly, Packing Tools, Gasket and Screw Set, and Grease Packet	12.7 (5.8)
V-5462-6004	Reconditioning Kit, 4 in. N.C. Flanged Valve, 3/8 in. Stem Type "M" for use with MP84 Pneumatic Actuator or Electric Actuator, Cv = 150.0; Includes Bonnet and Packing Items, Stem and Disk Assembly, Packing Tools, Gasket and Screw Set, and Grease Packet	16.3 (7.4)
V-5462-6005	Reconditioning Kit, 4 in. N.C. Flanged Valve, 1/2 in. Stem Type "N" for use with MP86 Pneumatic Actuator, Cv = 150.0; Includes Bonnet and Packing Items, Stem and Disk Assembly, Packing Assembly Tool, Gasket and Screw Set, and Grease Packet	17.4 (7.9)
V-5462-6006	Reconditioning Kit, 5 in. N.C. Flanged Valve, 1/2 in. Stem Type "N" for use with MP86 Pneumatic Actuator, Cv = 237.0; Includes Bonnet and Packing Items, Stem and Disk Assembly, Packing Assembly Tool, Gasket and Screw Set, and Grease Packet	23.7 (10.8)
V-5462-6007	Reconditioning Kit, 6 in. N.C. Flanged Valve, 1/2 in. Stem Type "N" for use with MP86 Pneumatic Actuator, Cv = 344.0; Includes Bonnet and Packing Items, Stem and Disk Assembly, Packing Assembly Tool, Gasket and Screw Set, and Grease Packet	31.1 (14.1)
V-5842-6001	Reconditioning Kit, 2-1/2 in. Mixing Flanged Valve, 3/8 in. Stem Type "M" for use with MP84 Pneumatic Actuator or Electric Actuator, Cv = 54.0; Includes Bonnet and Packing Items, Stem and Disk Assembly, Packing Tools, Gasket and Screw Set, and Grease Packet	8.1 (3.7)
V-5842-6002	Reconditioning Kit, 3 in. Mixing Flanged Valve, 3/8 in. Stem Type "M" for use with MP84 Pneumatic Actuator or Electric Actuator, Cv = 80.0; Includes Bonnet and Packing Items, Stem and Disk Assembly, Packing Tools, Gasket and Screw Set, and Grease Packet	10.8 (4.9)

Table 10: Ordering Data - VG2000 Series Reconditioning Kits (Part 3 of 3)

Code Number	Description	Shipping Weight, lb (kg)
V-5842-6003	Reconditioning Kit, 3 in. Mixing Flanged Valve, 1/2 in. Stem Type "N" for use with MP86 Pneumatic Actuator, Cv = 80.0; Includes Bonnet and Packing Items, Stem and Disk Assembly, Packing Assembly Tool, Gasket and Screw Set, and Grease Packet	12.3 (5.6)
V-5842-6004	Reconditioning Kit, 4 in. Mixing Flanged Valve with Electric Actuator, Cv =157.0; Includes Bonnet and Packing Items, Stem and Disk Assembly, Packing Tools, Gasket and Screw Set, and Grease Packet	16.6 (7.5)
V-5842-6005	Reconditioning Kit, 4 in. Mixing Flanged Valve, 1/2 in. Stem Type "N" for use with MP86 Pneumatic Actuator, Cv = 157.0; Includes Bonnet and Packing Items, Stem and Disk Assembly, Packing Assembly Tool, Gasket and Screw Set, and Grease Packet	17.8 (8.1)
V-5842-6006	Reconditioning Kit, 5 in. Mixing Flanged Valve, 1/2 in. Stem Type "N" for use with MP86 Pneumatic Actuator, Cv = 238.0; Includes Bonnet and Packing Items, Stem and Disk Assembly, Packing Assembly Tool, Gasket and Screw Set, and Grease Packet	22.0 (10.0)
V-5842-6007	Reconditioning Kit, 6 in. Mixing Flanged Valve, 1/2 in. Stem Type "N" for use with MP86 Pneumatic Actuator, Cv = 347.0; Includes Bonnet and Packing Items, Stem and Disk Assembly, Packing Assembly Tool, Gasket and Screw Set, and Grease Packet	31.9 (14.5)

Technical Specifications

VG2000 Series Cast Iron Flanged Globe Valves (Part 1 of 2)

Service ¹		Hot Water, Chilled Water, 50% Glycol Solutions or Steam for HVAC Systems
Valve Stroke		3/4 in. (19 mm) for 2-1/2 and 3 in. Valves 1-1/8 in. (29 mm) for 3 and 4 in. Valves 1-3/8 in. (35 mm) for 5 in. Valves 1-1/2 in. (38 mm) for 6 in. Valves
Valve Body Rating		Meets Requirements of ASME B16.1, Class 125
Valve Assembly Maximum Allowable Pressure/Temperature	Steam	35 to 284°F (2 to 140°C) 38 psig (262 kPa) Saturated Steam
	Water	175 psig (1,206 kPa) Up to 150°F (66°C), Decreasing to 125 psig (861 kPa) at 281°F (138°C)
Leakage	Brass Trim	0.1% of Maximum Flow
Inherent Flow Characteristics		Modified Linear
Rangeability ²	2-1/2 in. Valves	6.5:1
	3 in. Valves	7.7:1
	4 in. Valves	9.3:1
	5 in. Valves	10.7:1
	6 in. Valves	10.4:1
Spring Range Pneumatic Actuators		3 to 7 psig (21 to 48 kPa) 4 to 8 psig (28 to 55 kPa) 9 to 13 psig (62 to 90 kPa)
Maximum Recommended Operating Pressure Drop		35 psig (241 kPa) for All Valve Sizes

VG2000 Series Cast Iron Flanged Globe Valves (Part 2 of 2)

Maximum Actuator Supply Pressure (Pneumatically Actuated Valves Only)		25 psig (172 kPa) Maximum
Actuator Ambient Operating Temperature Limits	M91xx Series	-4 to 122°F (-20 to 50°C)
	M9220 Series	-40 to 131°F (-40 to 55°C)
	M100 Series	-40 to 125°F (-40 to 52°C) Non-spring Return -35 to 125°F (-37 to 52°C) Spring Return
	MP8000 Series	-20 to 150°F (-29 to 66°C)
	VA-3100 Series	14 to 140°F (-10 to 60°C) Floating Control 14 to 122°F (-10 to 50°C) Proportional Control
	VA-6100 Series	-4 to 140°F (-20 to 60°C)
Materials	Body	Cast Iron with Black Lacquer Finish
	Stem	Stainless Steel
	Plug	Brass
	Packing	Non-adjustable Ethylene Propylene Terpolymer (EPT) Ring Packs

1. Proper water treatment is recommended. (Refer to VDI 2035 Standard.)
2. Rangeability is defined as the ratio of maximum flow to minimum controllable flow.

The performance specifications are nominal and conform to acceptable industry standards. For application at conditions beyond these specifications, consult the local Johnson Controls office. Johnson Controls, Inc. shall not be liable for damages resulting from misapplication or misuse of its products.



Controls Group
507 E. Michigan Street
Milwaukee, WI 53202

*All other marks herein are the marks of their respective owners.
© 2007 Johnson Controls, Inc.*